

ENGINE SECTION 2

This service manual has been prepared to provide SUBARU service personnel with the necessary information and data for the correct maintenance and repair of SUBARU vehicles. This manual includes the procedures for maintenance, disassembling, reassembling, inspection and adjustment of components and diagnostics for guidance of experienced mechanics. Please peruse and utilize this manual fully to ensure complete repair work for satisfying our customers by keeping their vehicle in optimum condition. When replacement of parts during repair work is needed, be sure to use SUBARU genuine parts.

All information, illustration and specifications contained in this manual are based on the latest product information available at the time of publication approval.

FUEL INJECTION (FUEL SYSTEMS)	FU(H4DOTC)
EMISSION CONTROL (AUX. EMISSION CONTROL DEVICES)	EC(H4DOTC)
INTAKE (INDUCTION)	IN(H4DOTC)
MECHANICAL	ME(H4DOTC)
EXHAUST	EX(H4DOTC)
COOLING	CO(H4DOTC)
LUBRICATION	LU(H4DOTC)
SPEED CONTROL SYSTEMS	SP(H4DOTC)
IGNITION	IG(H4DOTC)
STARTING/CHARGING SYSTEMS	SC(H4DOTC)
ENGINE (DIAGNOSTICS)	EN(H4DOTC)(diag)

IGNITION

IG(H4DOTC)

	Page
1. General Description	2
2. Spark Plug.....	4
3. Ignition Coil & Ignitor ASSY	7

General Description

IGNITION

1. General Description

A: SPECIFICATION

Item		Specification
Ignition coil & ignitor ASSY	Model	FK0186
	Ignition system	Independent ignition coil
	Manufacturer	Diamond Electric
Spark plug	Manufacturer and type	NGK: ILFR6B
	Thread size (diameter, pitch, length) mm	14, 1.25, 19
	Spark plug gap mm (in)	0.7 — 0.8 (0.028 — 0.031)
	Electrode	Iridium

B: COMPONENT

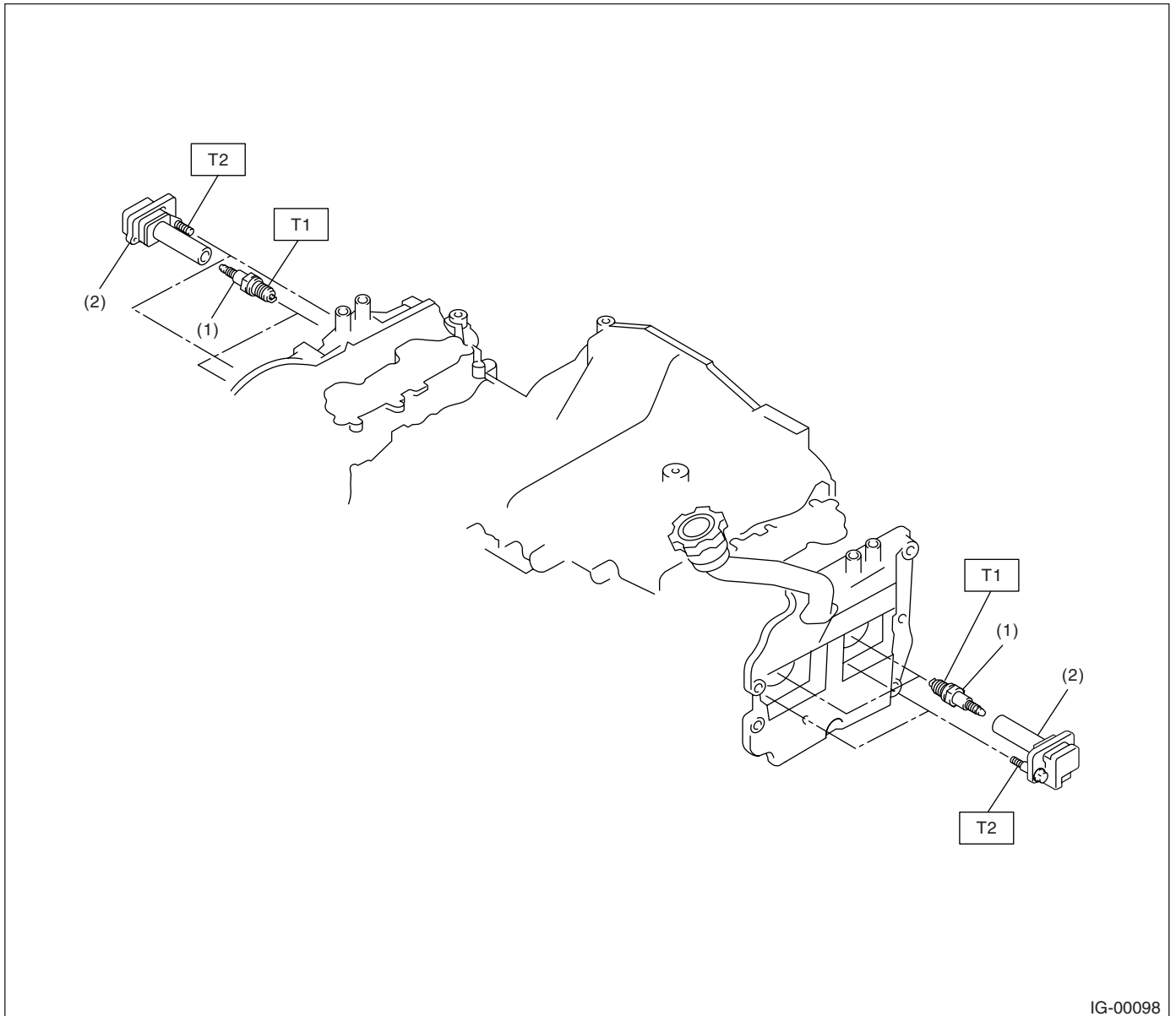

- (1) Spark plug
- (2) Ignition coil & ignitor ASSY

Tightening torque: N·m (kgf·m, ft·lb)

T1: 21 (2.1, 15.2)

T2: 16 (1.6, 11.7)

C: CAUTION

- Wear work clothing, including a cap, protective goggle and protective shoes during operation.
- Remove contamination including dirt and corrosion before removal, installation or disassembly.
- Keep the disassembled parts in order and protect them from dust and dirt.
- Before removal, installation or disassembly, be sure to clarify the failure. Avoid unnecessary removal, installation, disassembly and replacement.
- Be careful not to burn yourself, because each part on the vehicle is hot after running.
- Be sure to tighten fasteners including bolts and nuts to the specified torque.
- Place shop jacks or rigid racks at the specified points.
- Before disconnecting electrical connectors of sensors or units, be sure to disconnect the ground cable from battery.

Spark Plug

IGNITION

2. Spark Plug

A: REMOVAL

CAUTION:

All spark plugs installed on an engine must be of the same heat range.

Spark plug:

<Ref. to IG(H4DOTC)-2, SPECIFICATION, General Description.>

1. RH SIDE

- 1) Remove the collector cover.
- 2) Disconnect the ground cable from battery.

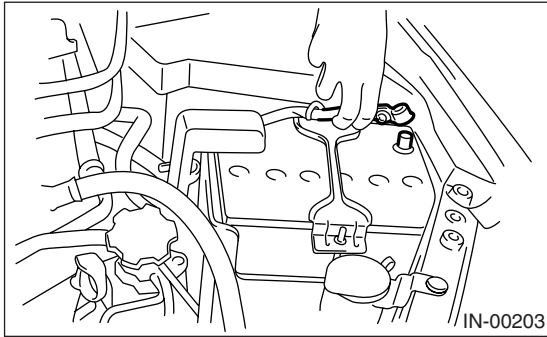

- 3) Remove the air cleaner case.
<Ref. to IN(H4DOTC)-8, REMOVAL, Air Cleaner Case.>
- 4) Disconnect the connector from ignition coil.
- 5) Remove the ignition coil.

NOTE:

Turn the #3 ignition coil by 180° to remove it.

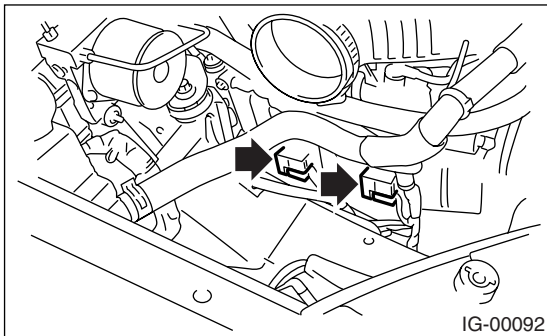

- 6) Remove the spark plug with a spark plug socket.

2. LH SIDE

- 1) Remove the collector cover.
- 2) Remove the battery and battery carrier.
- 3) Disconnect the connector from ignition coil.
- 4) Remove the ignition coil.

NOTE:

Turn the #4 ignition coil by 180° to remove it.

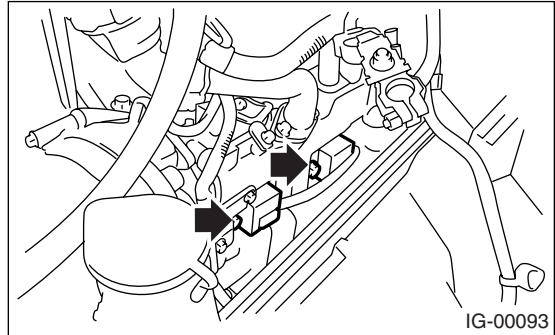

- 5) Remove the spark plug with a spark plug socket.

B: INSTALLATION

1. RH SIDE

Install in the reverse order of removal.

Tightening torque (Spark plug):
21 N·m (2.1 kgf-m, 15.2 ft-lb)

Tightening torque (Ignition coil):
16 N·m (1.6 kgf-m, 11.7 ft-lb)

NOTE:

The above torque should only be applied to new spark plugs without oil on their threads. In case their threads are lubricated, the torque should be reduced by approximately 1/3 of the specified torque in order to avoid over-stressing.

2. LH SIDE

Install in the reverse order of removal.

Tightening torque (Spark plug):
21 N·m (2.1 kgf-m, 15.2 ft-lb)

Tightening torque (Ignition coil):
16 N·m (1.6 kgf-m, 11.7 ft-lb)

NOTE:

The above torque should only be applied to new spark plugs without oil on their threads. In case their threads are lubricated, the torque should be reduced by approx. 1/3 of the specified torque in order to avoid over-stressing.

C: INSPECTION

Check the electrodes and inner and outer ceramic insulator of plugs, noting the type of deposits and the degree of electrode erosion.

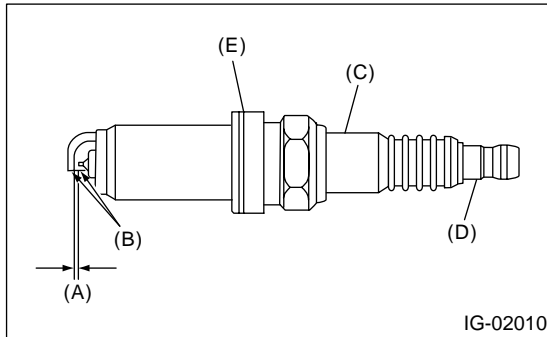

- (A) Spark plug gap
- (B) Carbon accumulation or wear
- (C) Crack
- (D) Damage
- (E) Damaged gasket

1) Normal:

Brown to grayish-tan deposits and slight electrode wear indicate correct spark plug heat range.

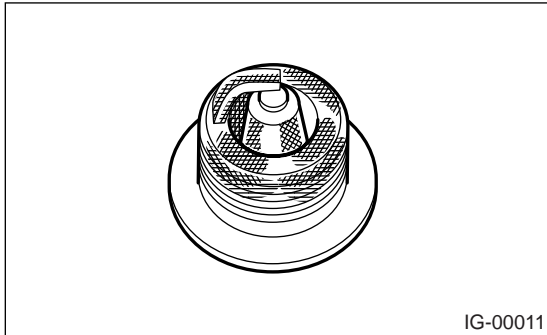

2) Carbon fouled:

Dry fluffy carbon deposits on insulator and electrode are mostly caused by slow speed driving in the city, weak ignition, too rich fuel mixture, dirty air cleaner, etc.

It is advisable to replace with plugs having hotter heat range.

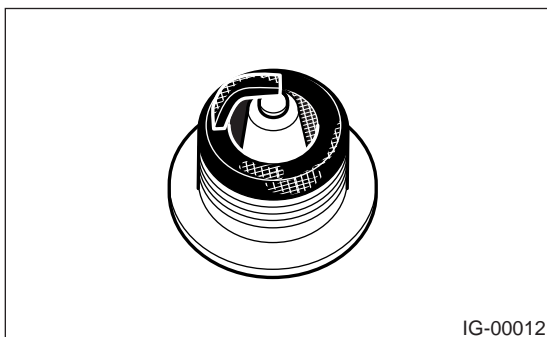

3) Oil fouled:

Wet black deposits show excessive oil entrance into combustion chamber through worn rings and pistons or excessive clearance between valve guides and stems. If the same condition remains after repair, use a hotter plug.

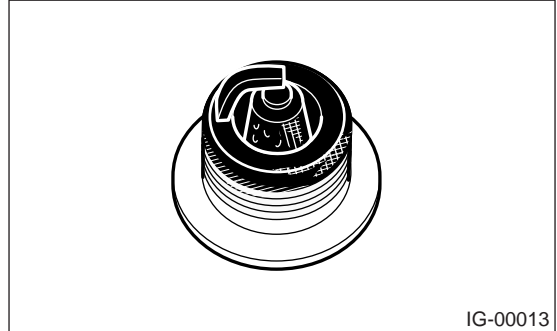

4) Overheating:

White or light gray insulator with black or brown spots and bluish burnt electrodes indicate engine overheating. Moreover, the appearance results from incorrect ignition timing, loose spark plugs, wrong selection of fuel, hotter range plug, etc. It is advisable to replace with plugs having colder heat range.

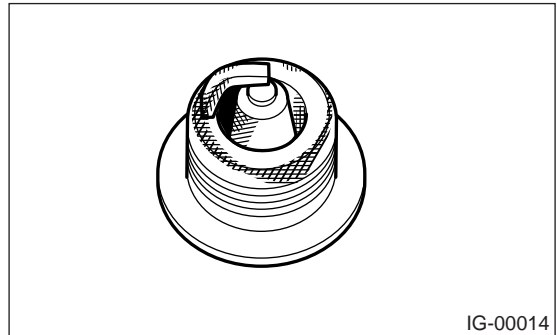

Spark Plug

IGNITION

D: ADJUSTMENT

Clean the spark plugs using a wire brush.

Clean and remove the carbon or oxide deposits.

But do not wear away ceramic insulator.

If deposits are too stubborn, replace the plugs.

After cleaning the spark plugs, correct the spark plug gap using a gap gauge.

NOTE:

Do not use a plug cleaner because the spark plugs are applied with iridium tip.

Spark plug gap: L

0.7 — 0.8 mm (0.028 — 0.031 in)

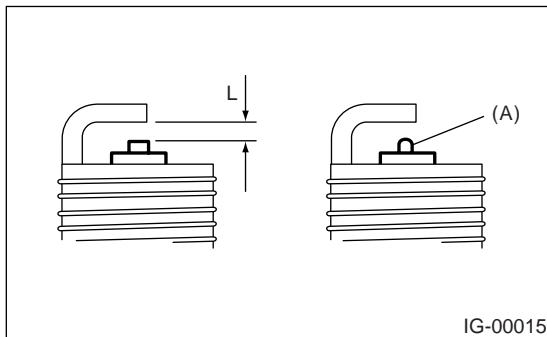

NOTE:

Replace with a new spark plug if this area (A) is worn to "ball" shape.

3. Ignition Coil & Ignitor ASSY

A: REMOVAL

Direct ignition type has been adopted. Refer to "Spark Plug" for removal procedure. <Ref. to IG(H4DOTC)-4, REMOVAL, Spark Plug.>

B: INSTALLATION

Install in the reverse order of removal.

Tightening torque:

16 N·m (1.6 kgf-m, 11.7 ft-lb)

C: INSPECTION

For inspection procedure, refer to "Diagnostics for Engine Starting Failure". <Ref. to EN(H4DOTC)(diag)-48, IGNITION CONTROL SYSTEM, Diagnostics for Engine Starting Failure.>

Ignition Coil & Ignitor ASSY

IGNITION

IG(H4DOTC)-8