

**SUPPLEMENT FOR 6 CYLINDER  
ENGINE MODEL**

This service manual has been prepared to provide SUBARU service personnel with the necessary information and data for the correct maintenance and repair of SUBARU vehicles.

This manual includes the procedures for maintenance, disassembling, reassembling, inspection and adjustment of components and diagnostics for guidance of experienced mechanics.

Please peruse and utilize this manual fully to ensure complete repair work for satisfying our customers by keeping their vehicle in optimum condition. When replacement of parts during repair work is needed, be sure to use SUBARU genuine parts.

All information, illustration and specifications contained in this manual are based on the latest product information available at the time of publication approval.

**FOREWORD**
**FW**
**HOW TO USE THIS MANUAL**
**HU**
**SPECIFICATIONS**
**SPC**
**PRECAUTION**
**PC**
**NOTE**
**NT**
**IDENTIFICATION**
**ID**
**RECOMMENDED MATERIALS**
**RM**
**PRE-DELIVERY INSPECTION**
**PI**
**PERIODICAL MAINTENANCE**
**PM**

**SUPPLEMENT FOR 6 CYLINDER  
ENGINE MODEL****FUEL INJECTION (FUEL SYSTEMS) FU(H6)****EMISSION CONTROL  
(AUX. EMISSION CONTROL DEVICES) EC(H6)****INTAKE (INDUCTION) IN(H6)****MECHANICAL ME(H6)****EXHAUST EX(H6)****COOLING CO(H6)****LUBRICATION LU(H6)****SPEED CONTROL SYSTEMS SP(H6)****IGNITION IG(H6)****START/CHARGING SYSTEMS SC(H6)****ENGINE (DIAGNOSTICS) EN(H6)****REAR SUSPENSION RS****WIRING SYSTEM WI**

# IGNITION

# *IG(H6)*

---

	<b>Page</b>
1. General Description.....	2
2. Spark Plug.....	4
3. Ignition Coil and Ignitor Assembly.....	7



# GENERAL DESCRIPTION

Ignition

## 1. General Description S141001

### A: SPECIFICATIONS S141001E49

Item		Designation
Ignition coil and ignitor assembly	Model	FK0140
	Manufacturer	DIAMOND
Spark plug	Type and manufacturer	PLFR6A-11 ..... NGK
	Thread size	mm 14, P = 1.25
	Spark gap	mm (in) 1.0 — 1.1 (0.039 — 0.043)

## B: COMPONENT S141001A05

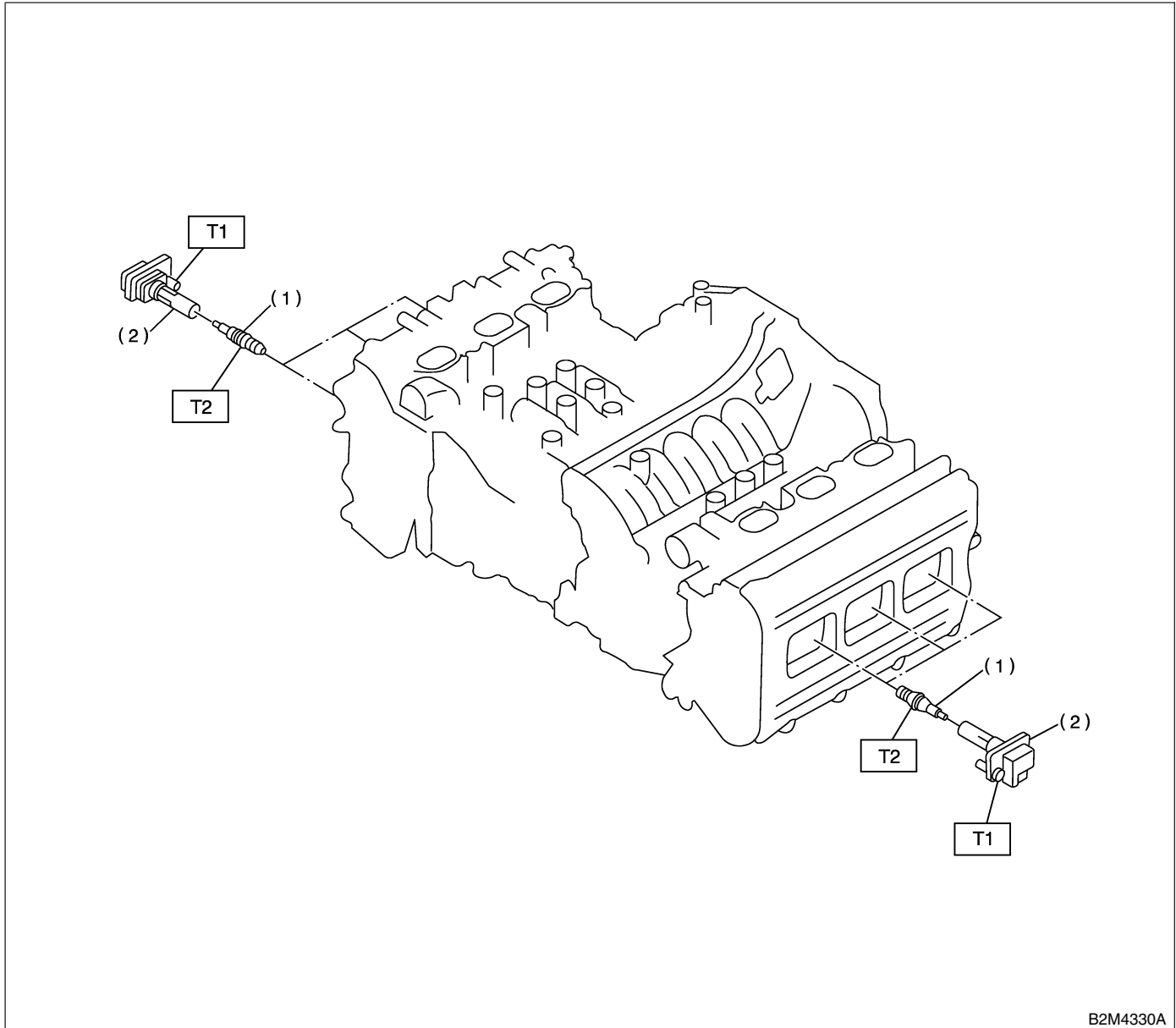

B2M4330A

- (1) Spark plug
- (2) Ignition coil and ignitor ASSY

**Tightening torque: N·m (kgf·m, ft·lb)**

**T1: 16 (1.6, 12)**

**T2: 21 (2.1, 15)**

## C: CAUTION S141001A03

- Wear working clothing, including a cap, protective goggles, and protective shoes during operation.
- Remove contamination including dirt and corrosion before removal, installation or disassembly.
- Keep the disassembled parts in order and protect them from dust or dirt.
- Before removal, installation or disassembly, be sure to clarify the failure. Avoid unnecessary

removal, installation, disassembly, and replacement.

- Be careful not to burn your hands, because each part on the vehicle is hot after running.
- Be sure to tighten fasteners including bolts and nuts to the specified torque.
- Place shop jacks or safety stands at the specified points.
- Before disconnecting electrical connectors of sensors or units, be sure to disconnect negative terminal from battery.

# SPARK PLUG

Ignition

## 2. Spark Plug S141003

### A: REMOVAL S141003A18

#### CAUTION:

All spark plugs installed on an engine, must be of the same heat range.

Spark plug:

**NGK: PLFR6A-11**

#### 1. RH SIDE S141003A1805

- 1) Disconnect battery ground cable.

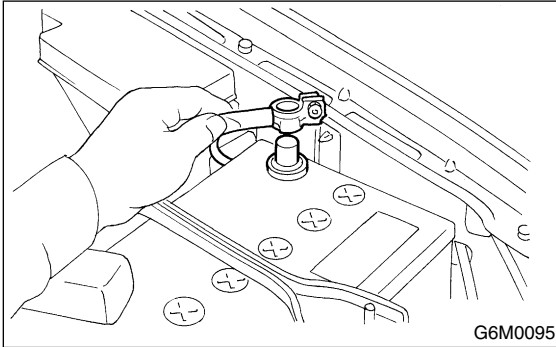

- 2) Remove air cleaner lower case. <Ref. to IN(H6)-5, REMOVAL, Air Cleaner.>
- 3) Disconnect connector from ignition coil.
- 4) Remove ignition coil.

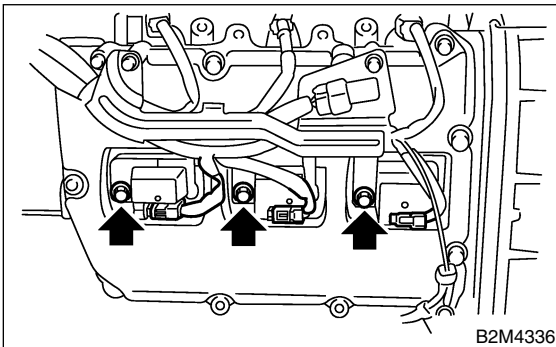

- 5) Remove spark plugs with the spark plug socket.

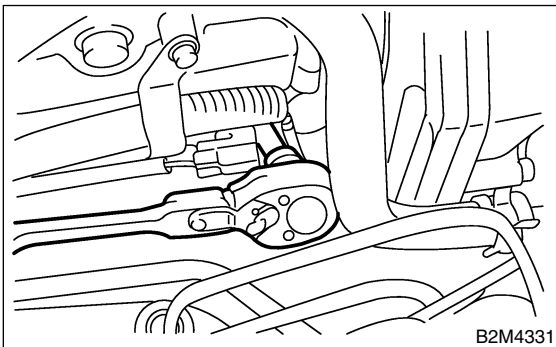

#### 2. LH SIDE S141003A1806

- 1) Disconnect battery cables and then remove battery and battery carrier.

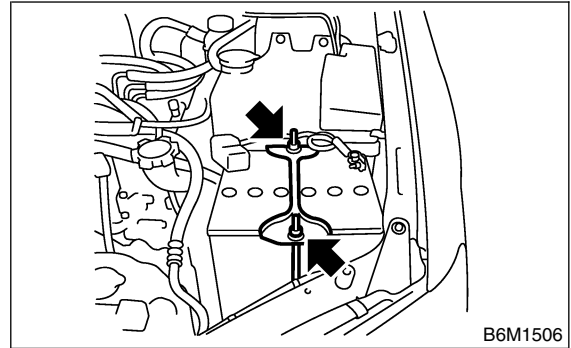

- 2) Disconnect washer motor connector.

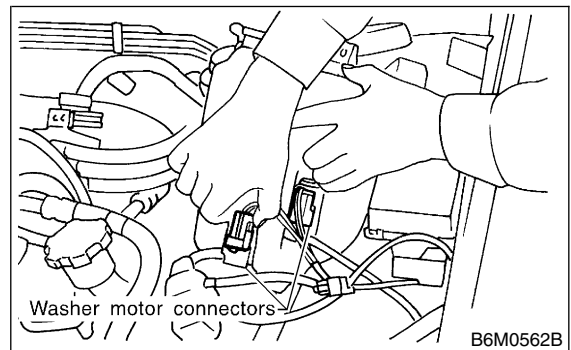

- 3) Remove the two bolts which hold the washer tank, then take the tank away from the working area.

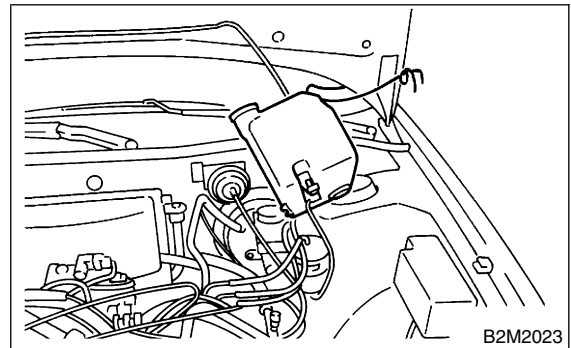

- 4) Disconnect connector from ignition coil.
- 5) Remove ignition coil.

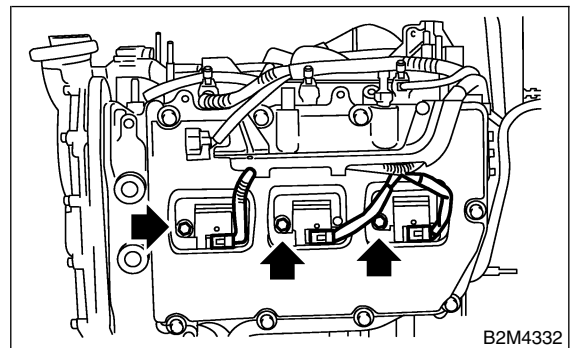

6) Remove spark plug with the spark plugs socket.

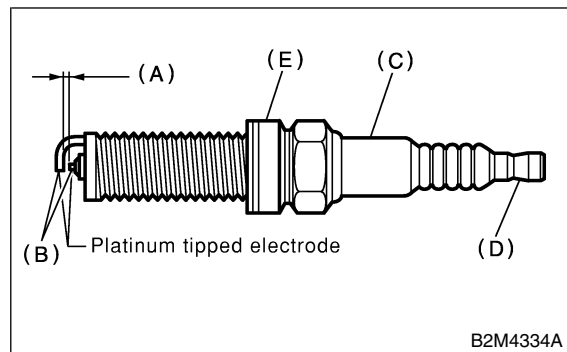
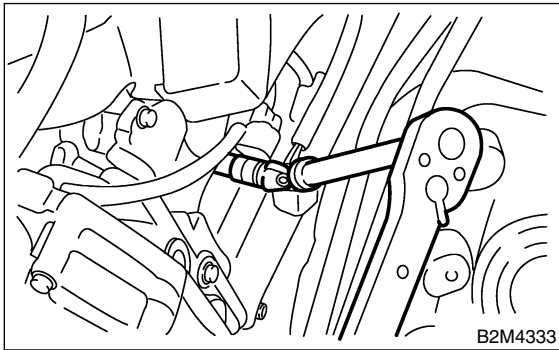

- (A) Electrode gap
- (B) Carbon accumulation or wear
- (C) Cracks
- (D) Damage
- (E) Damaged gasket

## B: INSTALLATION S141003A11

### 1. RH SIDE S141003A1105

Install in the reverse order of removal.

**Tightening torque (Spark plug):**  
**21 N·m (2.1 kgf-m, 15 ft-lb)**

#### CAUTION:

The above torque should be only applied to new spark plugs without oil on their threads. In case their threads are lubricated, the torque should be reduced by approximately 1/3 of the specified torque in order to avoid over-stressing.

**Tightening torque (Ignition coil):**  
**16 N·m (1.6 kgf-m, 12 ft-lb)**

### 2. LH SIDE S141003A1106

Install in the reverse order of removal.

**Tightening torque (Spark plug):**  
**21 N·m (2.1 kgf-m, 15 ft-lb)**

#### CAUTION:

The above torque should be only applied to new spark plugs without oil on their threads. In case their threads are lubricated, the torque should be reduced by approximately 1/3 of the specified torque in order to avoid over-stressing.

**Tightening torque (Ignition coil):**  
**16 N·m (1.6 kgf-m, 12 ft-lb)**

## C: INSPECTION S141003A10

Check electrodes and inner and outer porcelain of plugs, noting the type of deposits and the degree of electrode erosion.

### 1) Normal

Brown to grayish-tan deposits and slight electrode wear indicate correct spark plug heat range.

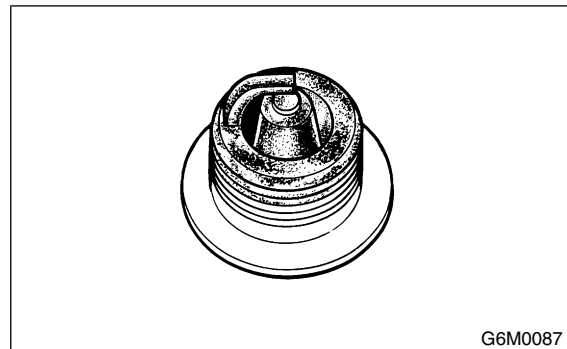

### 2) Carbon fouled

Dry fluffy carbon deposits on insulator and electrode are mostly caused by slow speed driving in city, weak ignition, too rich fuel mixture, dirty air cleaner, etc.

It is advisable to replace with plugs having hotter heat range.

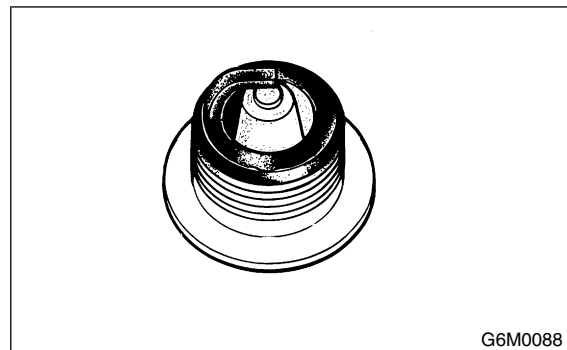

# SPARK PLUG

## Ignition

### 3) Oil fouled

Wet black deposits show excessive oil entrance into combustion chamber through worn rings and pistons or excessive clearance between valve guides and stems. If same condition remains after repair, use a hotter plug.

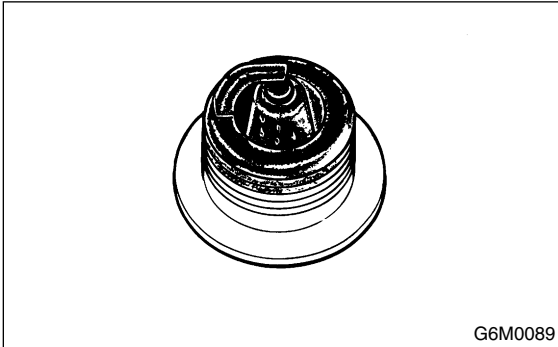

### 4) Overheating

White or light gray insulator with black or gray brown spots and bluish burnt electrodes indicate engine overheating. Moreover, the appearance results from incorrect ignition timing, loose spark plugs, wrong selection of fuel, hotter range plug, etc. It is advisable to replace with plugs having colder heat range.

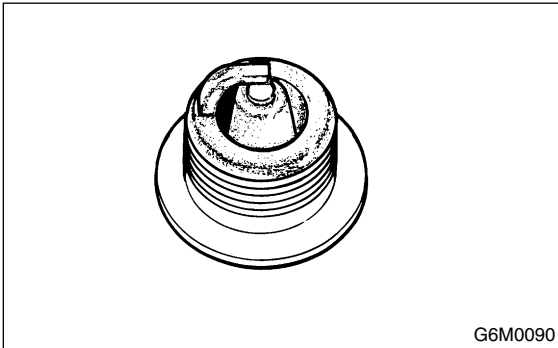

## E: ADJUSTMENT S141003A01

Correct it if the spark plug gap is measured with a gap gauge, and it is necessary.

**Spark plug gap: L**

**1.0 — 1.1 mm (0.039 — 0.043 in)**

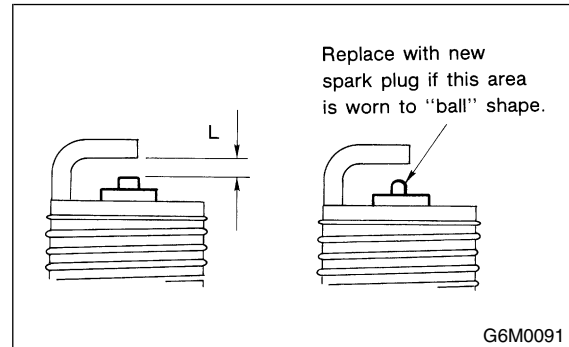

## D: CLEANING S141003E56

Clean spark plugs in a sand blast type cleaner. Avoid excessive blasting. Clean and remove carbon or oxide deposits, but do not wear away porcelain.

If deposits are too stubborn, replace plugs.



### 3. Ignition Coil and Ignitor Assembly S141015

#### A: REMOVAL S141015A18

Direct ignition type is adopted.  
For the order of removal, refer to the removal of spark plugs.

#### B: INSTALLATION S141015A11

Install in the reverse order of removal.

#### *Tightening torque:*

**16 N·m (1.6 kgf-m, 12 ft-lb)**

#### C: INSPECTION S141015A10

Because ignition coil is a direct ignition type, the resistance cannot be measured in a single unit. For inspection procedure of ignition system, refer to the following. <Ref. to EN(H6)-77, IGNITION CONTROL SYSTEM, Diagnostics for Engine Starting Failure.>

# IGNITION COIL AND IGNITOR ASSEMBLY

Ignition

---

**MEMO:**