

**ENGINE SECTION 2**

This service manual has been prepared to provide SUBARU service personnel with the necessary information and data for the correct maintenance and repair of SUBARU vehicles.

This manual includes the procedures for maintenance, disassembling, reassembling, inspection and adjustment of components and diagnostics for guidance of experienced mechanics.

Please peruse and utilize this manual fully to ensure complete repair work for satisfying our customers by keeping their vehicle in optimum condition. When replacement of parts during repair work is needed, be sure to use SUBARU genuine parts.

All information, illustration and specifications contained in this manual are based on the latest product information available at the time of publication approval.

**FUEL INJECTION (FUEL SYSTEM) FU(H4DOTC)**

**EMISSION CONTROL (AUX. EMISSION CONTROL DEVICE) EC(H4DOTC)**

**INTAKE (INDUCTION) IN(H4DOTC)**

**MECHANICAL ME(H4DOTC)**

**EXHAUST EX(H4DOTC)**

**COOLING CO(H4DOTC)**

**LUBRICATION LU(H4DOTC)**

**SPEED CONTROL SYSTEM SP(H4DOTC)**

**IGNITION IG(H4DOTC)**

**STARTING/CHARGING SYSTEM SC(H4DOTC)**

**ENGINE (DIAGNOSTIC) EN(H4DOTC)**



# EXHAUST

# *EX(H4DOTC)*

---

	<b>Page</b>
1. General Description .....	2
2. Front Exhaust Pipe.....	7
3. Center Exhaust Pipe .....	9
4. Joint Pipe .....	13
5. Rear Exhaust Pipe .....	14
6. Muffler .....	16

# General Description

EXHAUST

## 1. General Description

### A: COMPONENT

#### 1. FRONT EXHAUST PIPE

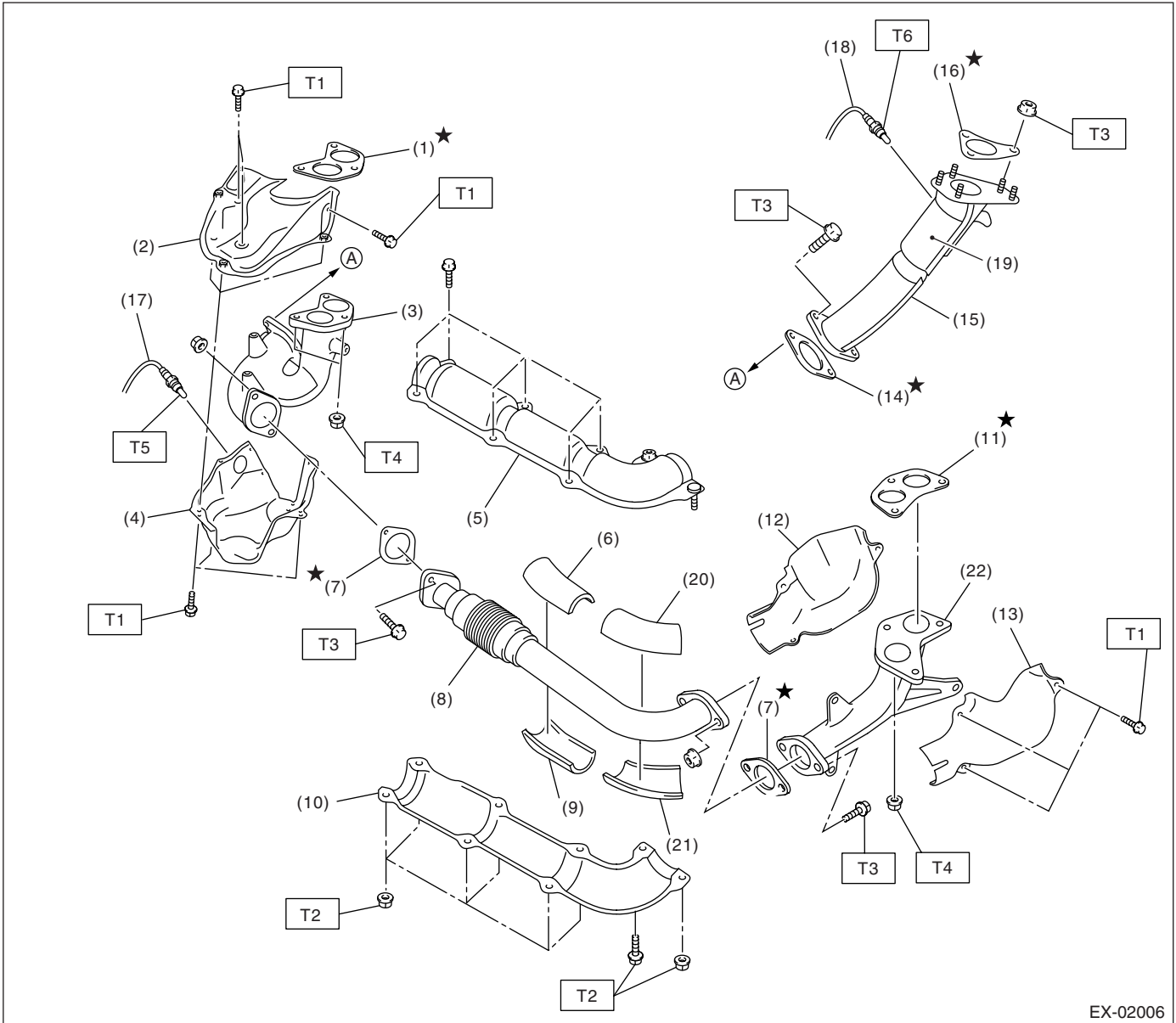

EX-02006

# General Description

EXHAUST

---

(1) Gasket	(12) Exhaust manifold upper cover (LH)	<b>Tightening torque: N·m (kgf-m, ft-lb)</b> <b>T1: 19 (1.9, 13.7)</b> <b>T2: 7.5 (0.8, 5.5)</b> <b>T3: 35 (3.6, 26.0)</b> <b>T4: 40 (4, 28.9)</b> <b>T5: &lt;Ref. to FU(H4DOTC)-45, INSTALLATION, Front Oxygen (A/F) Sensor.&gt; or &lt;Ref. to FU(H4DOTC 2.5)-37, INSTALLATION, Front Oxygen (A/F) Sensor.&gt;</b> <b>T6: &lt;Ref. to FU(H4DOTC)-49, INSTALLATION, Exhaust Temperature Sensor.&gt; or &lt;Ref. to FU(H4DOTC 2.5)-40, INSTALLATION, Exhaust Temperature Sensor.&gt;</b>
(2) Exhaust manifold upper cover (RH)	(13) Exhaust manifold lower cover (LH)	
(3) Exhaust manifold (RH)	(14) Gasket	
(4) Exhaust manifold lower cover (RH)	(15) Turbocharger joint pipe	
(5) Front exhaust pipe upper cover	(16) Gasket	
(6) Front exhaust pipe upper insulator (RH)	(17) Front oxygen (A/F) sensor	
(7) Gasket	(18) Exhaust temperature sensor	
(8) Front exhaust pipe	(19) Precatalytic converter	
(9) Front exhaust pipe lower insulator (RH)	(20) Front exhaust pipe upper insulator (LH)	
(10) Front exhaust pipe lower cover	(21) Front exhaust pipe lower insulator (LH)	
(11) Gasket	(22) Exhaust manifold (LH)	

---

# General Description

## EXHAUST

### 2. CENTER AND REAR EXHAUST PIPE, AND MUFFLER

- 2.0 L model

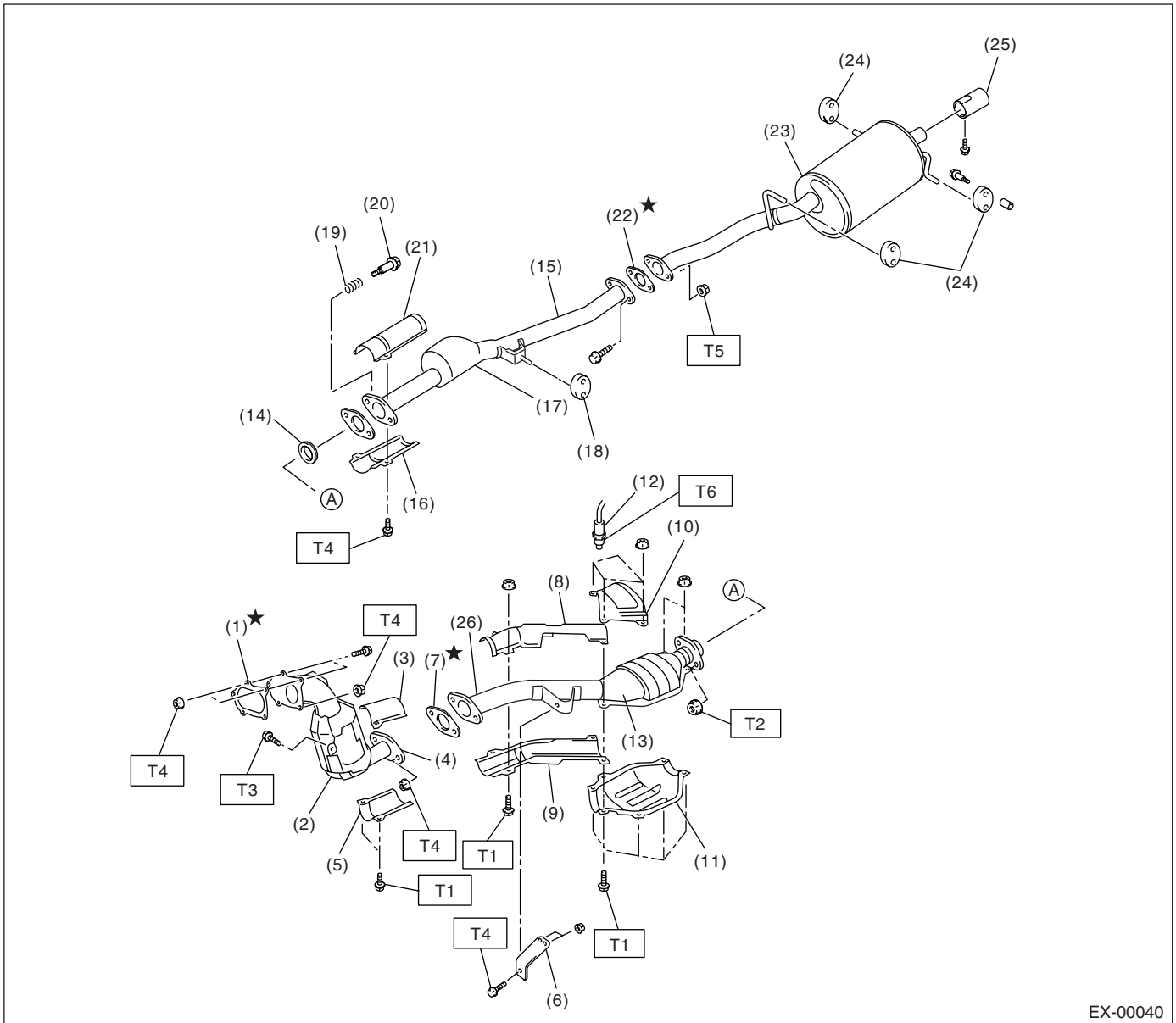

EX-00040

- |   |  |
|---|--|
| (1) Gasket                                | (13) Rear catalytic converter              |
| (2) Front catalytic converter             | (14) Gasket                                |
| (3) Center pipe upper cover (Front)       | (15) Rear exhaust pipe                     |
| (4) Center exhaust pipe (Front)           | (16) Lower rear exhaust pipe cover (Front) |
| (5) Center pipe lower cover (Front)       | (17) Chamber                               |
| (6) Bracket                               | (18) Cushion                               |
| (7) Gasket                                | (19) Spring                                |
| (8) Center pipe upper cover (Rear)        | (20) Bolt                                  |
| (9) Center pipe lower cover (Rear)        | (21) Upper rear exhaust pipe cover (Front) |
| (10) Upper rear catalytic converter cover | (22) Gasket                                |
| (11) Lower rear catalytic converter cover | (23) Muffler                               |
| (12) Rear oxygen sensor                   | (24) Cushion rubber                        |

- |                                 |
|---------------------------------|
| (25) Muffler cutter             |
| (26) Center exhaust pipe (Rear) |

---

**Tightening torque: N·m (kgf·m, ft·lb)**

**T1: 13 (1.3, 9.6)**

**T2: 18 (1.8, 13.0)**

**T3: 30 (3.1, 22.4)**

**T4: 35 (3.6, 26.0)**

**T5: 48 (4.9, 35.4)**

**T6: <Ref. to FU(H4DOTC)-47, INSTALLATION, Rear Oxygen Sensor.>**

---

# General Description

EXHAUST

- 2.5 L model

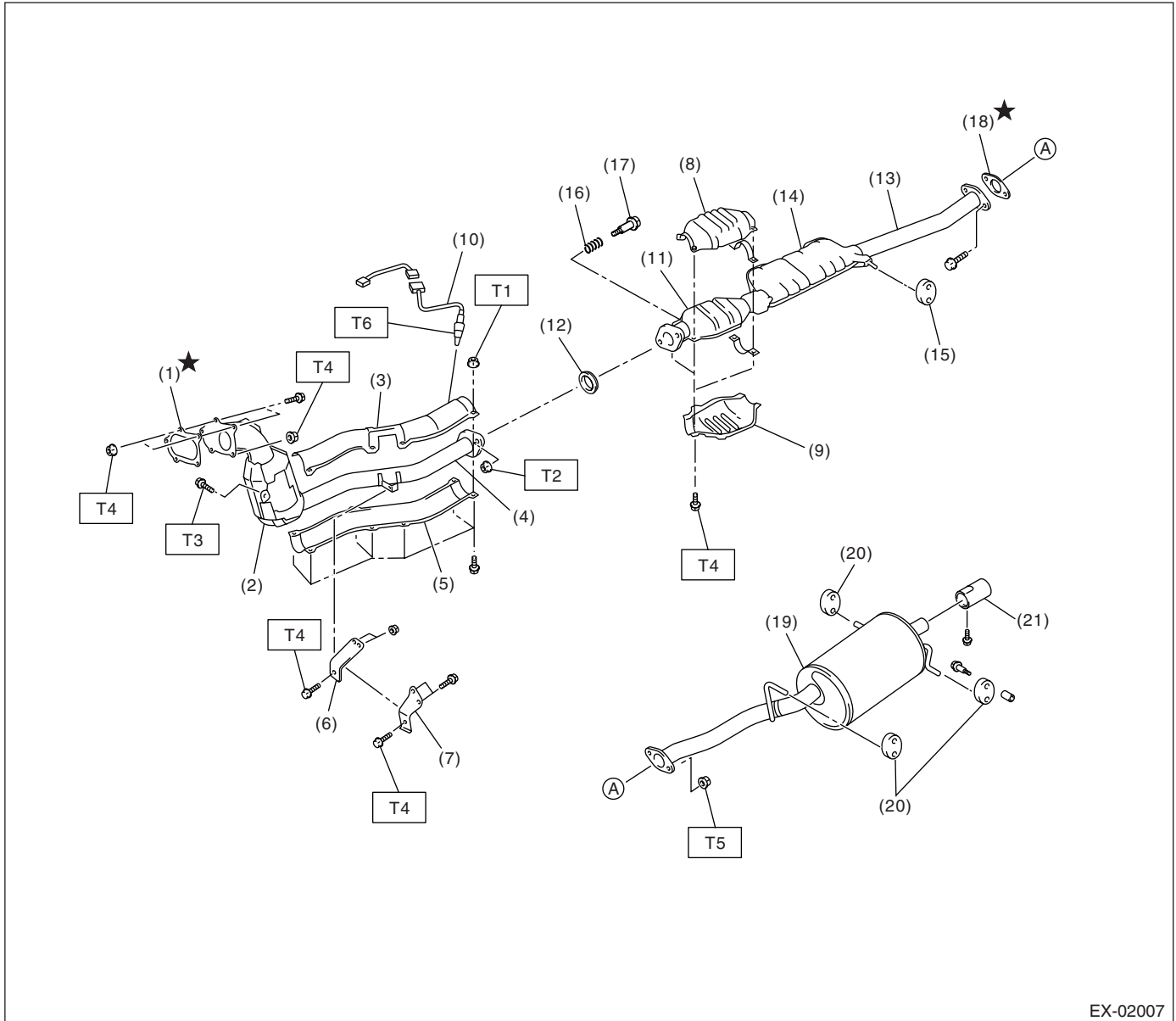

EX-02007

- |                                     |                        |
|-------------------------------------|------------------------|
| (1) Gasket                          | (12) Gasket            |
| (2) Front catalytic converter       | (13) Rear exhaust pipe |
| (3) Center pipe upper cover         | (14) Chamber           |
| (4) Center exhaust pipe             | (15) Cushion rubber    |
| (5) Center pipe lower cover         | (16) Spring            |
| (6) Bracket (MT model)              | (17) Bolt              |
| (7) Bracket (AT model)              | (18) Gasket            |
| (8) Catalytic converter upper cover | (19) Muffler           |
| (9) Catalytic converter lower cover | (20) Cushion rubber    |
| (10) Rear oxygen sensor             | (21) Muffler cutter    |
| (11) Rear catalytic converter       |                        |

**Tightening torque: N-m (kgf-m, ft-lb)**

**T1: 13 (1.3, 9.6)**

**T2: 18 (1.8, 13.0)**

**T3: 30 (3.1, 22.4)**

**T4: 35 (3.6, 26.0)**

**T5: 48 (4.9, 35.4)**

**T6: <Ref. to FU(H4DOTC 2.5)-38, INSTALLATION, Rear Oxygen Sensor.>**

#### **B: CAUTION**

- Wear working clothing, including a cap, protective goggles, and protective shoes during operation.
- Remove contamination including dirt and corrosion before removal, installation or disassembly.
- Keep the disassembled parts in order and protect them from dust or dirt.
- Before removal, installation or disassembly, be sure to clarify the failure. Avoid unnecessary removal, installation, disassembly, and replacement.
- Be careful not to burn yourself, because each part on the vehicle is hot after running.
- Be sure to tighten fasteners including bolts and nuts to the specified torque.
- Place shop jacks or rigid racks at the specified points.
- Before disconnecting electrical connectors of sensors or units, be sure to disconnect the ground cable from battery.



## 2. Front Exhaust Pipe

### A: REMOVAL

- 1) Disconnect the ground cable from battery.

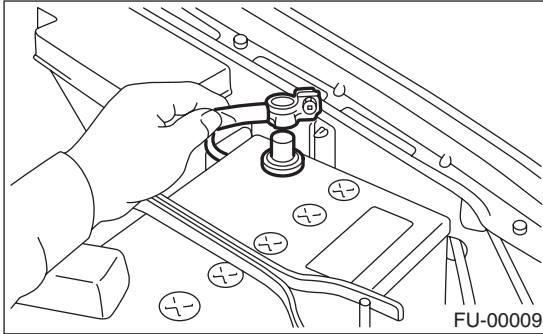

- 2) Remove the front oxygen (A/F) sensor. <Ref. to FU(H4DOTC)-45, REMOVAL, Front Oxygen (A/F) Sensor.> or <Ref. to FU(H4DOTC 2.5)-36, REMOVAL, Front Oxygen (A/F) Sensor.>
- 3) Remove the under cover.
- 4) Remove the lower exhaust manifold cover.

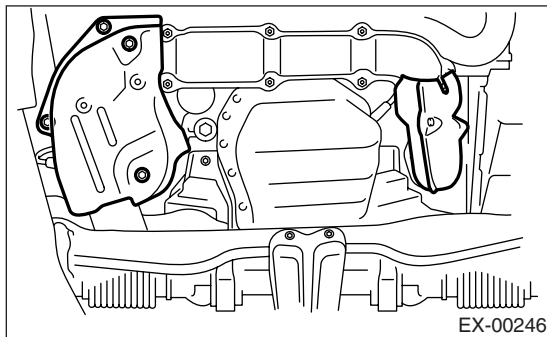

- 5) Remove the nuts which hold front exhaust pipe assembly to turbocharger joint pipe.
- 6) While holding the front exhaust pipe assembly with one hand, remove the nuts which hold front exhaust pipe assembly to cylinder head exhaust port.

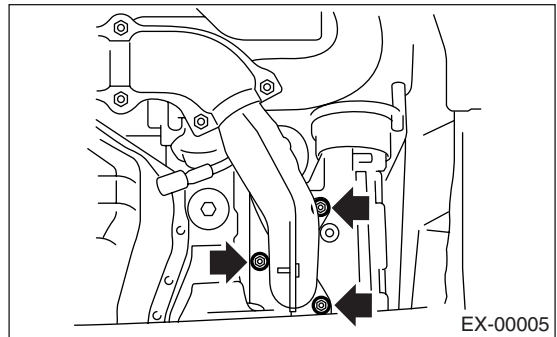
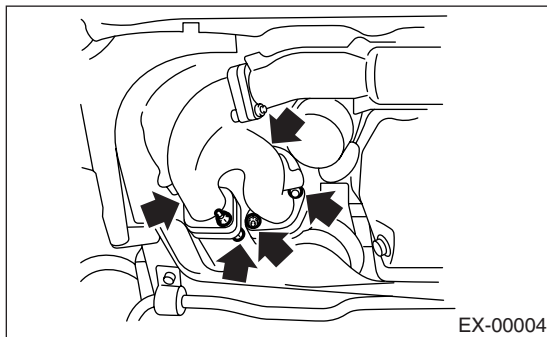

- 7) Remove the front exhaust pipe assembly.
- 8) Remove the covers from exhaust manifold and front exhaust pipe.
- 9) Separate the front exhaust pipe from exhaust manifolds.

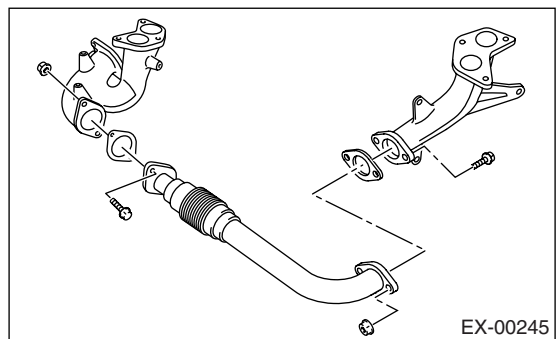

### B: INSTALLATION

**NOTE:**

Replace the gaskets with new ones.

- 1) Assemble the front exhaust pipe and exhaust manifolds.

**Tightening torque:**

**35 N·m (3.6 kgf-m, 26.0 ft-lb)**

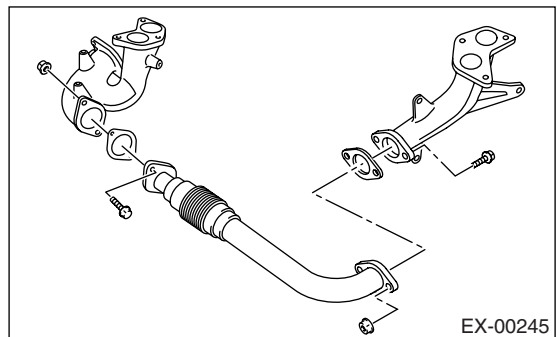

- 2) Install the front exhaust pipe covers.

**Tightening torque:**

**7.5 N·m (0.8 kgf-m, 5.5 ft-lb)**

- 3) Install the exhaust manifold upper cover (RH).

**Tightening torque:**

**19 N·m (1.9 kgf-m, 13.7 ft-lb)**

# Front Exhaust Pipe

## EXHAUST

4) Install the front exhaust pipe assembly.

**Tightening torque:**

**35 N·m (3.6 kgf-m, 26.0 ft-lb)**

5) Connect the exhaust manifold (RH) to turbo-charger joint pipe.

**Tightening torque:**

**T1: 35 N·m (3.6 kgf-m, 26.0 ft-lb)**

**T2: 40 N·m (4.0 kgf-m, 28.9 ft-lb)**

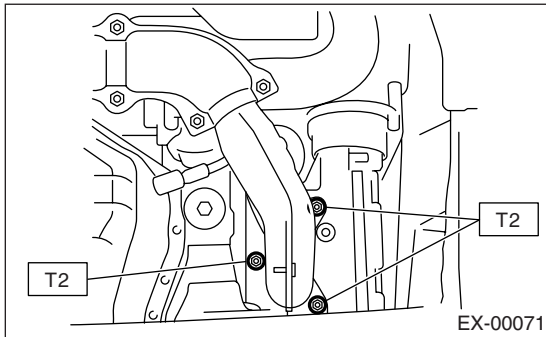
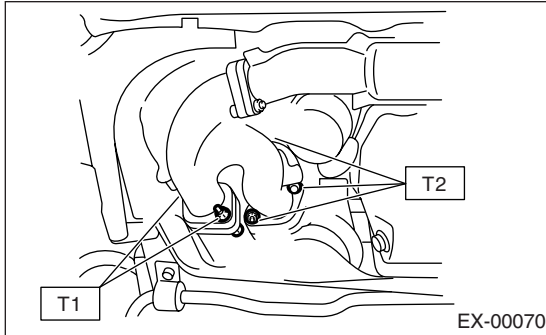

6) Install the exhaust manifold lower cover.

**Tightening torque:**

**19 N·m (1.9 kgf-m, 13.7 ft-lb)**

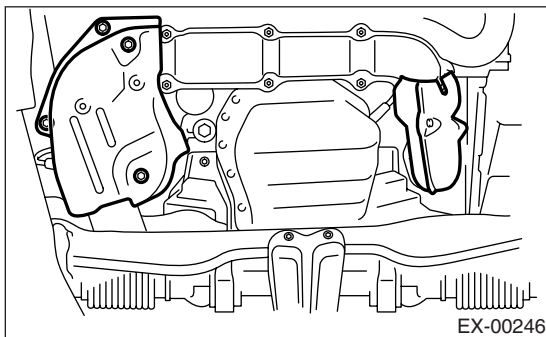

7) Install the front oxygen (A/F) sensor. <Ref. to FU(H4DOTC)-45, INSTALLATION, Front Oxygen (A/F) Sensor.> or <Ref. to FU(H4DOTC 2.5)-37, INSTALLATION, Front Oxygen (A/F) Sensor.>

8) Install the under cover.

9) Connect the battery ground cable to battery.

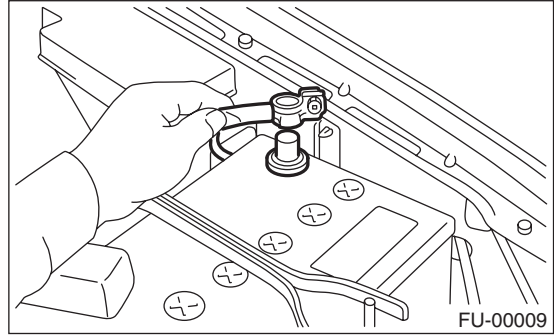

## 3. Center Exhaust Pipe

### A: REMOVAL

- 1) Set the vehicle on a lift.
- 2) Disconnect the ground cable from battery.
- 3) Remove the intercooler.  
<Ref. to IN(H4DOTC)-10, REMOVAL, Intercooler.>
- 4) Remove the intercooler bracket.

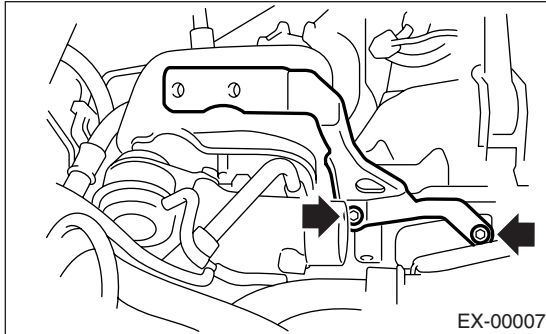

- 5) Lift-up the vehicle.
- 6) Remove the under cover.
- 7) Remove the universal joint bolts and then remove the universal joint. (RHD model)

**CAUTION:**

**Scribe alignment marks on the universal joint so that it can be reassembled at the original serration.**

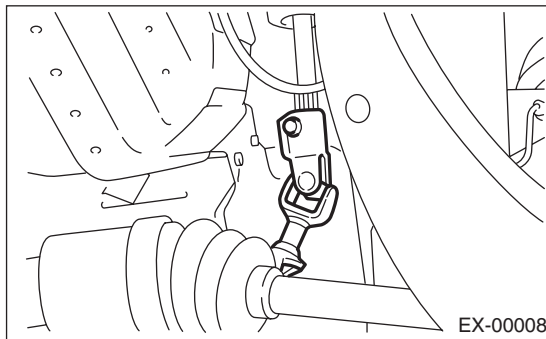

- 8) Remove the bolts which install lower side of turbocharger upper cover.

**CAUTION:**

**Be careful, the turbocharger and exhaust pipe are hot.**

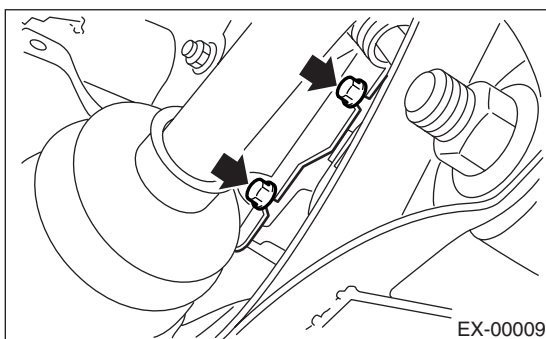

- 9) Lower the vehicle.
- 10) Remove the turbocharger upper cover.

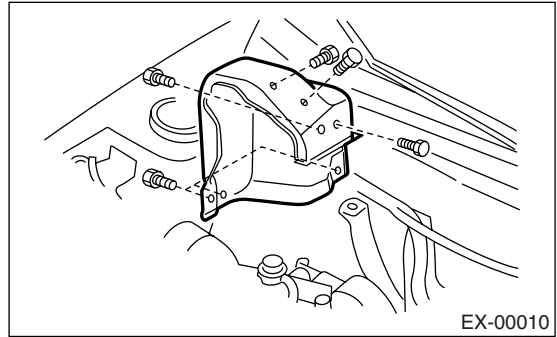

- 11) Remove the bolts which install upper side of turbocharger upper cover, and remove it.

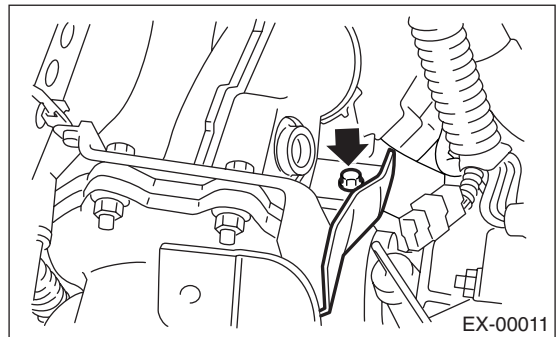

- 12) Separate the center exhaust pipe from turbocharger.

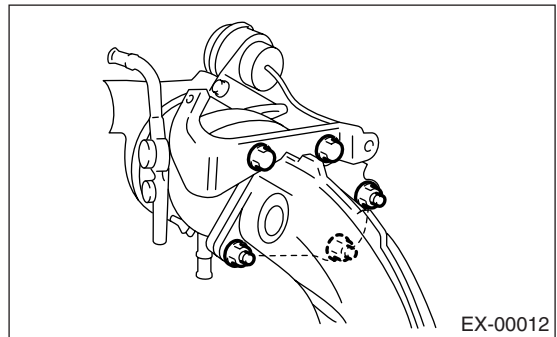

- 13) Lift-up the vehicle.
- 14) Disconnect the connector from rear oxygen sensor.

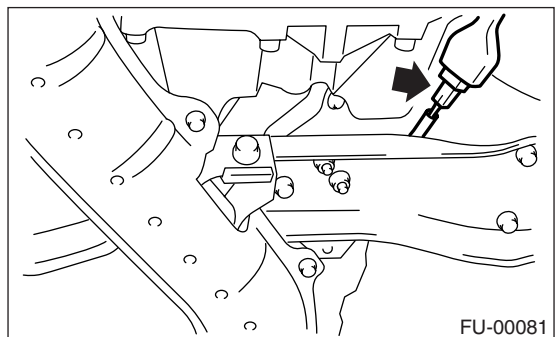

# Center Exhaust Pipe

## EXHAUST

15) Remove the clip by pulling out from the upper side of crossmember.

- AT model

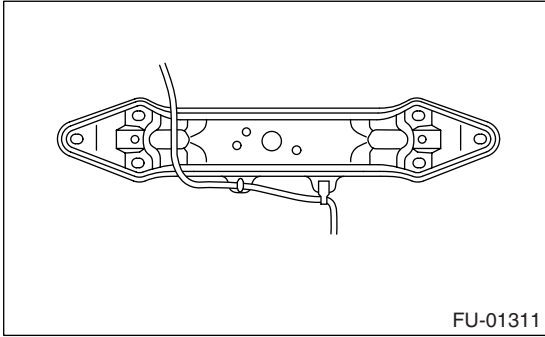

- MT model

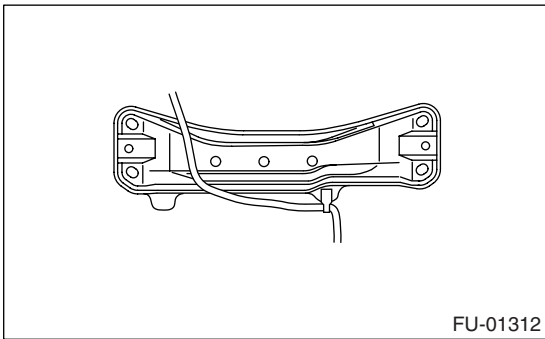

16) Separate the center exhaust pipe from rear exhaust pipe.

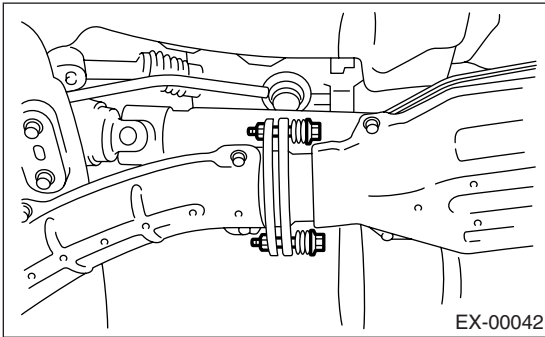

17) Remove the bolt which holds center exhaust pipe bracket to transmission.

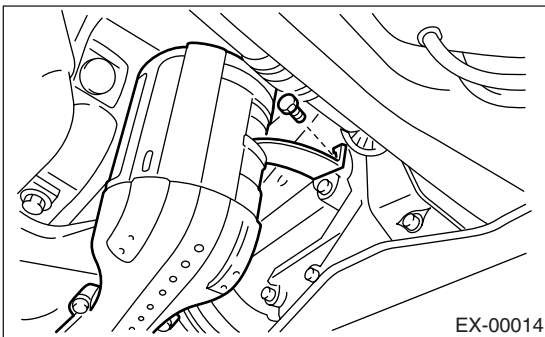

18) Remove the intercooler bracket.

19) Remove the bolt which holds center exhaust pipe to hanger bracket.

### CAUTION:

Be careful not to pull down the center exhaust pipe.

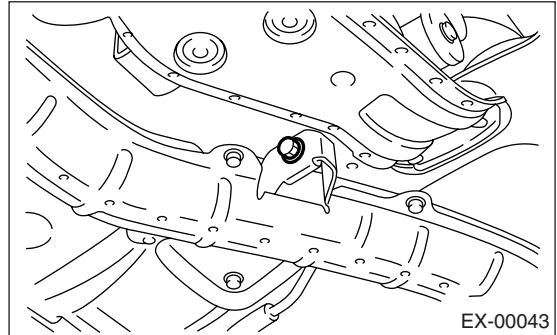

20) Remove the center exhaust pipe.

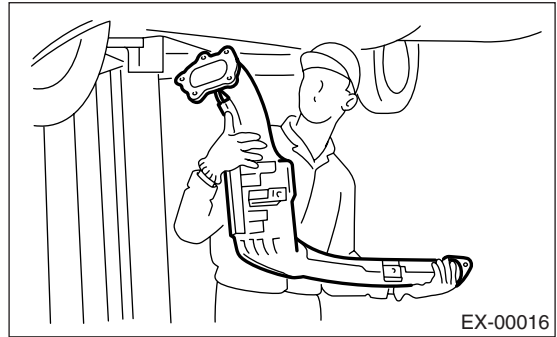

## B: INSTALLATION

### NOTE:

Replace the gaskets with new ones.

- 1) Install the center exhaust pipe and temporarily tighten the bolt which holds center exhaust pipe to hanger bracket.
- 2) Temporarily tighten the bolt which holds center pipe to transmission.
- 3) Connect the center exhaust pipe to turbocharger.

### Tightening torque:

**35 N·m (3.6 kgf-m, 26.0 ft-lb)**

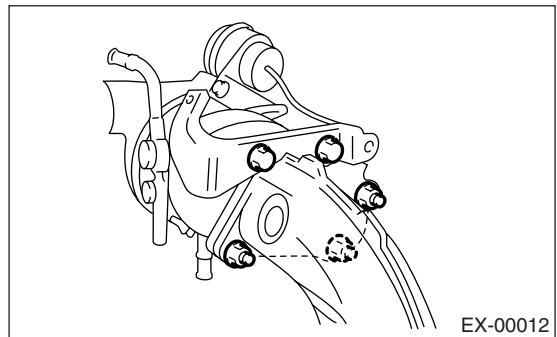

# Center Exhaust Pipe

EXHAUST

4) Install the center exhaust pipe to rear exhaust pipe.

**Tightening torque:**

**18 N·m (1.8 kgf-m, 13.0 ft-lb)**

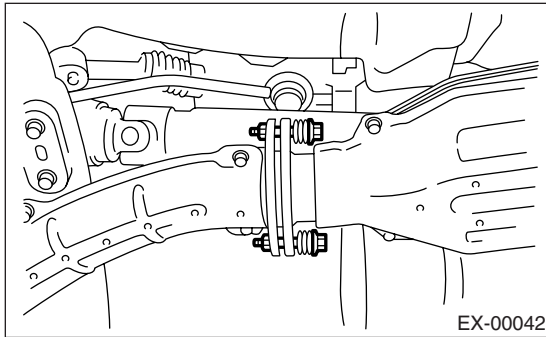

5) Connect the connector to rear oxygen sensor.

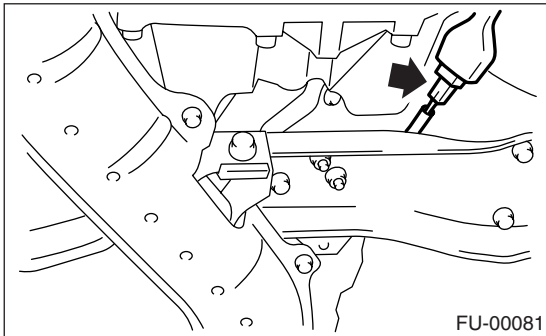

6) Secure the clip on crossmember.

- AT model

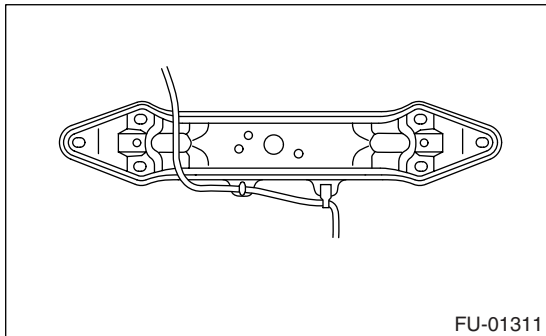

- MT model

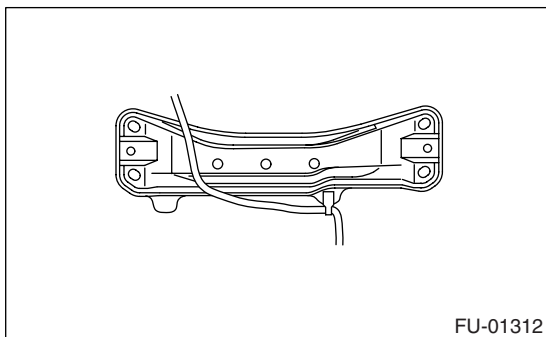

7) Tighten the bolt which holds center exhaust pipe bracket to transmission.

**Tightening torque:**

**30 N·m (3.1 kgf-m, 22.4 ft-lb)**

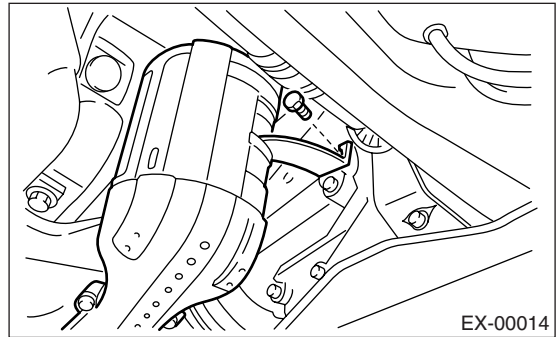

8) Tighten the bolt which holds center exhaust pipe to hanger bracket.

**Tightening torque:**

**35 N·m (3.6 kgf-m, 26.0 ft-lb)**

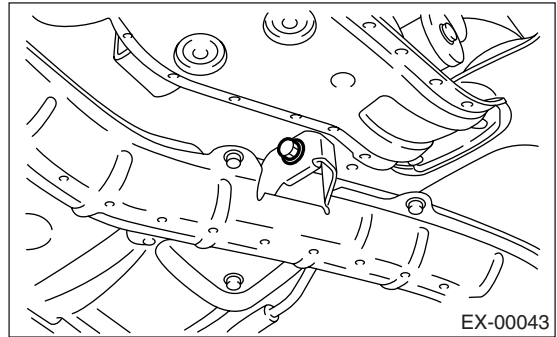

9) Tighten the bolts which hold intercooler bracket.

**Tightening torque:**

**35 N·m (3.6 kgf-m, 26.0 ft-lb)**

10) Lower the vehicle.

11) Place the turbocharger lower cover, and tighten the bolts which install upper side of lower cover.

**Tightening torque:**

**7.4 N·m (0.75 kgf-m, 5.4 ft-lb)**

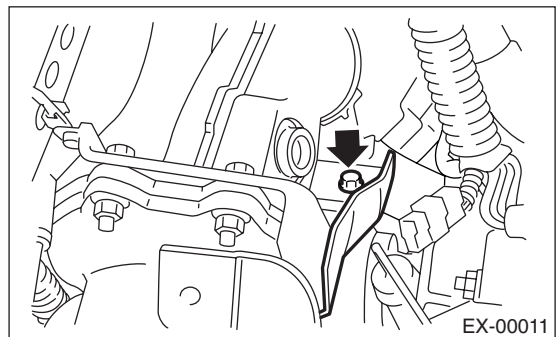

## Center Exhaust Pipe

### EXHAUST

12) Place the turbocharger upper cover, and tighten the bolts which install upper side of upper cover.

**Tightening torque:**

**7.4 N·m (0.75 kgf·m, 5.4 ft·lb)**

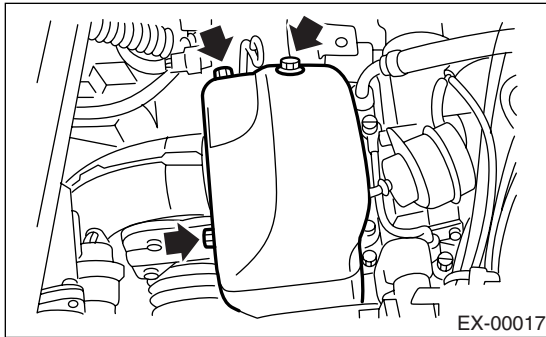

13) Lift-up the vehicle.

14) Tighten the bolts which install under side of turbocharger upper cover.

**Tightening torque:**

**7.4 N·m (0.75 kgf·m, 5.4 ft·lb)**

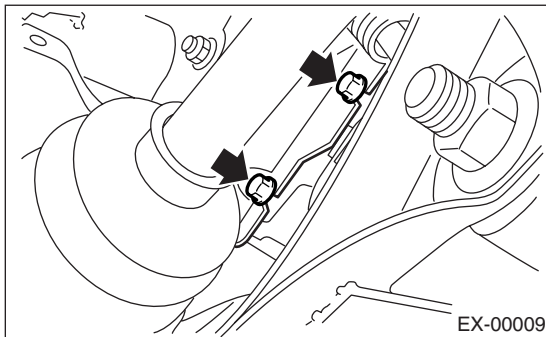

15) Install the universal joint. (RHD model)

(1) Align the bolt hole on long yoke side of universal joint with the cutout at serrated section of shaft end, and insert the universal joint.

(2) Align the bolt hole on short yoke side of universal joint with the cutout at serrated section of gearbox assembly. Lower the universal joint completely.

(3) Temporarily tighten the bolt on short yoke side. Raise the universal joint to make sure the bolt is properly passing through the cutout at serrated section.

(4) Tighten the bolt on long yoke side, then that on the short yoke side.

**Tightening torque:**

**24 N·m (2.4 kgf·m, 17.4 ft·lb)**

**CAUTION:**

- Make sure that the universal joint bolts are tightened through notches in shaft serration.
- Excessively large tightening torque of universal joint bolts may lead to heavy steering wheel operation.

**Standard clearance between gearbox to DOJ:**

**Over 15 mm (0.59 in)**

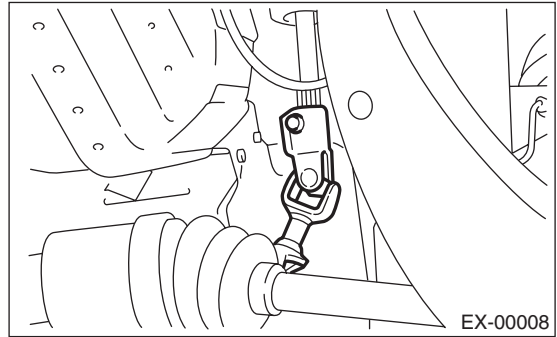

16) Install the under cover.

17) Lower the vehicle.

18) Install the intercooler bracket.

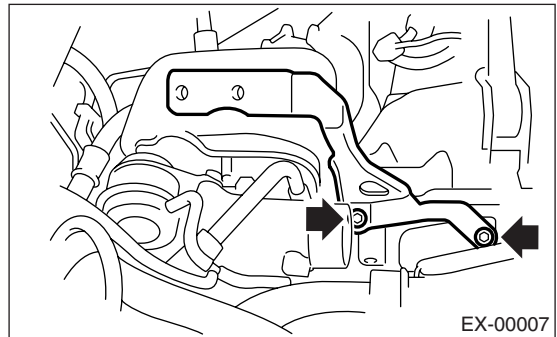

19) Install the intercooler.

<Ref. to IN(H4DOTC)-11, INSTALLATION, Intercooler.>

20) Align the center of roll connector. (RHD model)

<Ref. to AB-13, ROLL CONNECTOR, INSPECTION, Inspection Locations After a Collision.>



## 4. Joint Pipe

### A: REMOVAL

1) Disconnect the ground cable from battery.

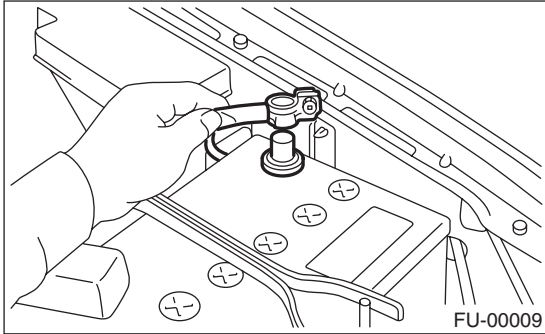

2) Disconnect the exhaust temperature sensor connector.

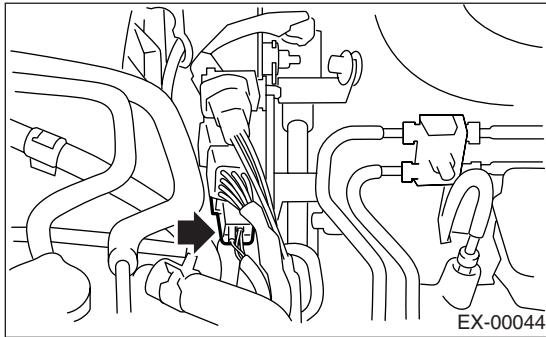

3) Remove the front oxygen (A/F) sensor. <Ref. to FU(H4DOTC)-45, REMOVAL, Front Oxygen (A/F) Sensor.> or <Ref. to FU(H4DOTC 2.5)-36, REMOVAL, Front Oxygen (A/F) Sensor.>

4) Remove the under cover.

5) Remove the exhaust manifold lower cover (RH).

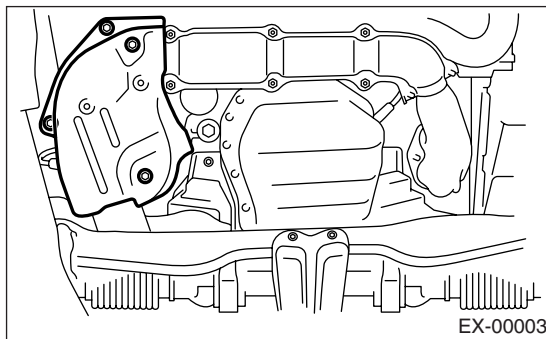

6) Remove the nuts which hold front exhaust manifold to joint pipe.

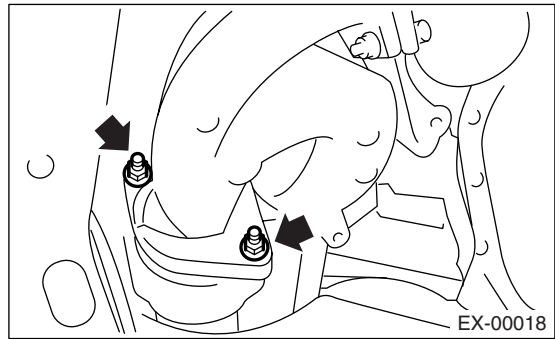

7) Remove the center exhaust pipe. <Ref. to EX(H4DOTC)-9, REMOVAL, Center Exhaust Pipe.>

8) Remove the turbocharger.

<Ref. to IN(H4DOTC)-12, REMOVAL, Turbocharger.>

9) Take off the joint pipe in the upward direction.

### B: INSTALLATION

Install in the reverse order of removal.

**Tightening torque:**

**T: 35 N·m (3.6 kgf-m, 26.0 ft-lb)**

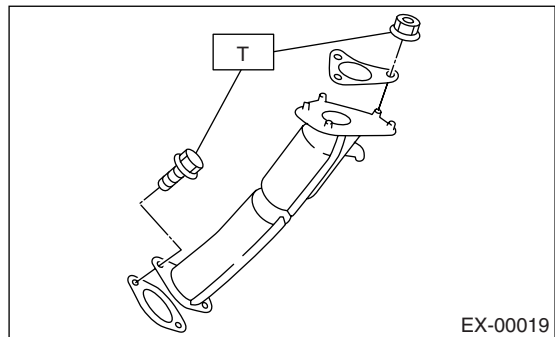

# Rear Exhaust Pipe

EXHAUST

## 5. Rear Exhaust Pipe

### A: REMOVAL

1) Disconnect the ground cable from battery.

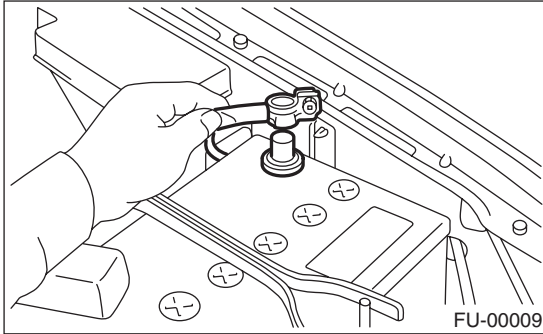

2) Lift-up the vehicle.

3) Separate the rear exhaust pipe from center exhaust pipe.

#### CAUTION:

Be careful, the exhaust pipe is hot.

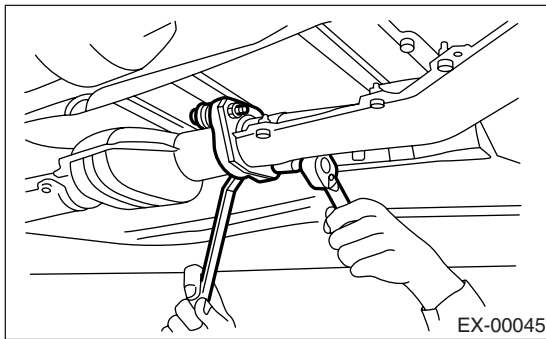

4) Separate the rear exhaust pipe from muffler.

#### CAUTION:

Be careful not to pull down the rear exhaust pipe.

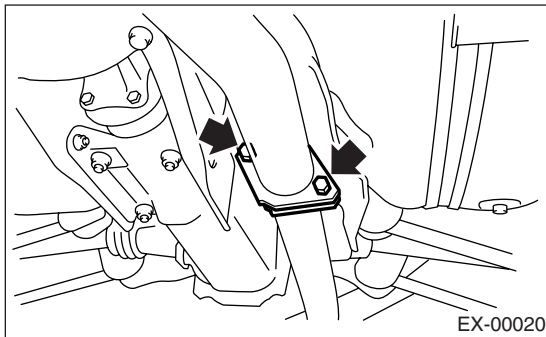

5) Separate the rear exhaust pipe from cushion rubber, and then remove.

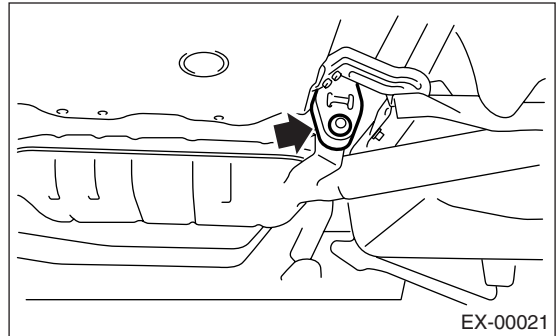

### B: INSTALLATION

#### NOTE:

Replace the gasket and nuts with new ones.

1) Install the rear exhaust pipe to cushion rubber.

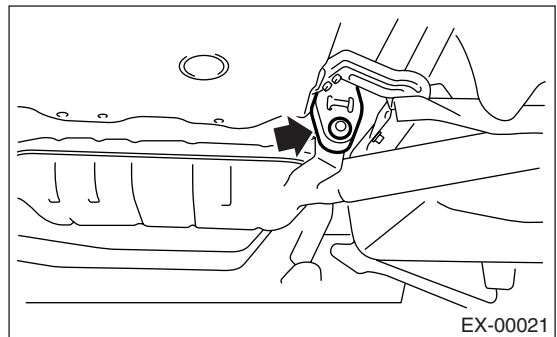

2) Install the rear exhaust pipe to muffler.

#### Tightening torque:

**48 N·m (4.9 kgf·m, 35.4 ft·lb)**

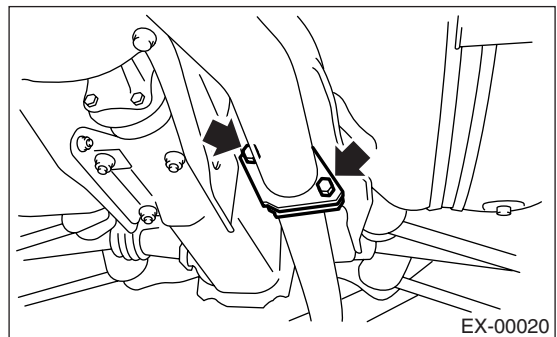



3) Install the rear exhaust pipe to center exhaust pipe.

**Tightening torque:**

**18 N·m (1.8 kgf·m, 13.0 ft·lb)**

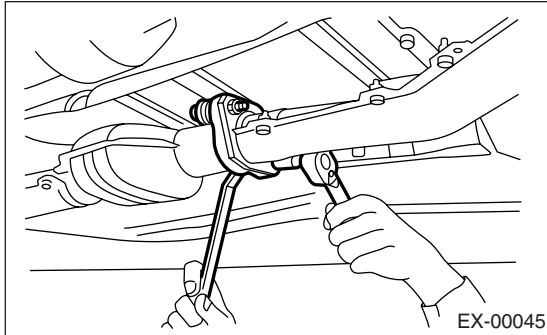

4) Lower the vehicle.

5) Connect the battery ground cable to battery.

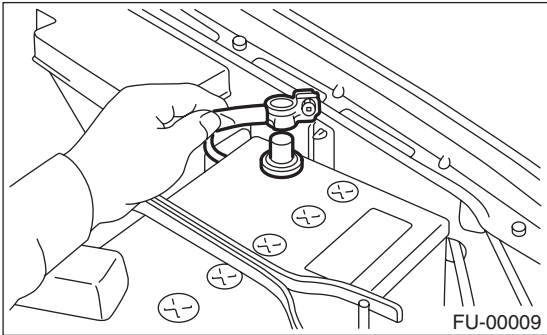

## C: INSPECTION

- 1) Make sure there are no exhaust leaks from connections and welds.
- 2) Make sure there are no holes or rusting.
- 3) Make sure the cushion rubber is not worn or cracked.

# Muffler

## EXHAUST

### 6. Muffler

#### A: REMOVAL

1) Separate the muffler from rear exhaust pipe.

#### CAUTION:

Be careful, the exhaust pipe is hot.

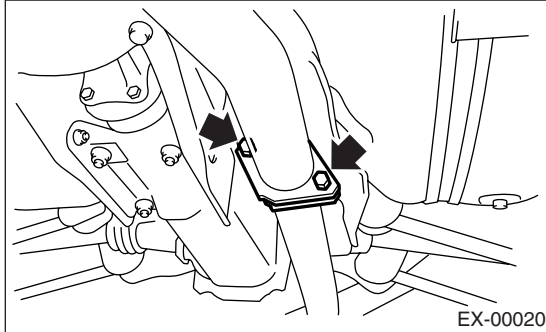

2) Remove the cushions rubber, and detach the muffler.

#### CAUTION:

Be careful not to drop the muffler during removal.

#### NOTE:

To facilitate removal, apply a coat of SUBARU CRC to the mating area of cushions rubber in advance.

**SUBARU CRC (Part No. 004301003)**

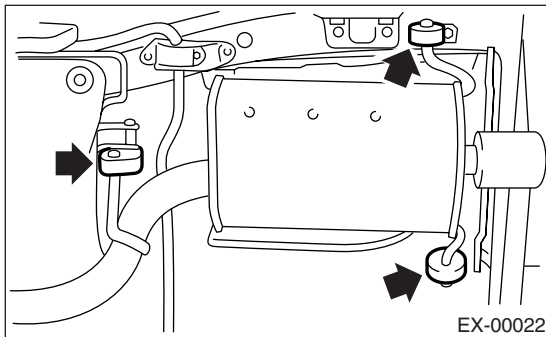

#### B: INSTALLATION

Install in the reverse order of removal.

#### NOTE:

Replace the gasket and nuts with new ones.

#### Tightening torque:

**48 N·m (4.9 kgf-m, 35.4 ft-lb)**

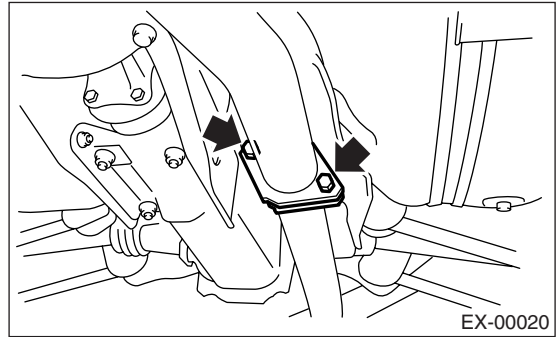

#### C: INSPECTION

- 1) Make sure there are no exhaust leaks from connections and welds.
- 2) Make sure there are no holes or rusting.
- 3) Make sure the cushions rubber is not worn or cracked.