

ENGINE SECTION 1

This service manual has been prepared to provide SUBARU service personnel with the necessary information and data for the correct maintenance and repair of SUBARU vehicles.

This manual includes the procedures for maintenance, disassembling, reassembling, inspection and adjustment of components and diagnostics for guidance of experienced mechanics.

Please peruse and utilize this manual fully to ensure complete repair work for satisfying our customers by keeping their vehicle in optimum condition. When replacement of parts during repair work is needed, be sure to use SUBARU genuine parts.

All information, illustration and specifications contained in this manual are based on the latest product information available at the time of publication approval.

FUEL INJECTION (FUEL SYSTEM) FU(H4SO)

**EMISSION CONTROL
(AUX. EMISSION CONTROL DEVICE) EC(H4SO)**

INTAKE (INDUCTION) IN(H4SO)

MECHANICAL ME(H4SO)

EXHAUST EX(H4SO)

COOLING CO(H4SO)

LUBRICATION LU(H4SO)

SPEED CONTROL SYSTEM SP(H4SO)

IGNITION IG(H4SO)

STARTING/CHARGING SYSTEM SC(H4SO)

ENGINE (DIAGNOSTIC) EN(H4SO)

SPEED CONTROL SYSTEM

SP(H4SO)

	Page
1. General Description	2
2. Accelerator Pedal.....	4
3. Accelerator Control Cable	9

General Description

SPEED CONTROL SYSTEM

1. General Description

A: SPECIFICATION

Accelerator pedal	Free play	At pedal pad	0 — 4 mm (0 — 0.16 in)
	Stroke	At pedal pad	52 — 57 mm (2.05 — 2.24 in)

B: COMPONENT

1. LHD MODEL

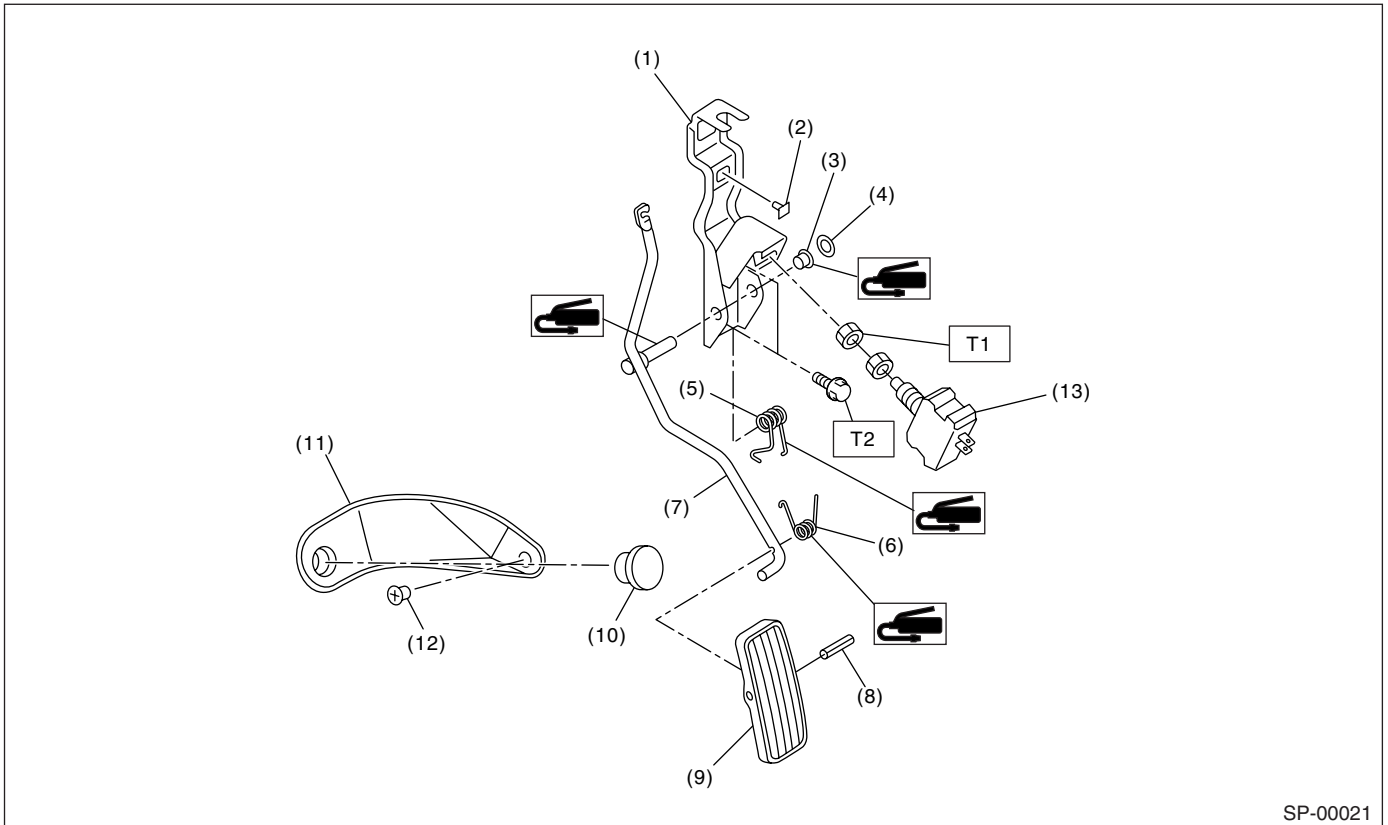

(1) Accelerator bracket

(2) Stopper

(3) Bushing

(4) Clip

(5) Accelerator spring

(6) Accelerator pedal spring

(7) Accelerator pedal lever

(8) Spring pin

(9) Accelerator pedal

(10) Accelerator stopper

(11) Accelerator plate

(12) Clip

(13) Kick-down switch (AT model)

Tightening torque: N·m (kgf·m, ft·lb)

T1: 12 (1.2, 9.0)

T2: 18 (1.8, 13.0)

2. RHD MODEL

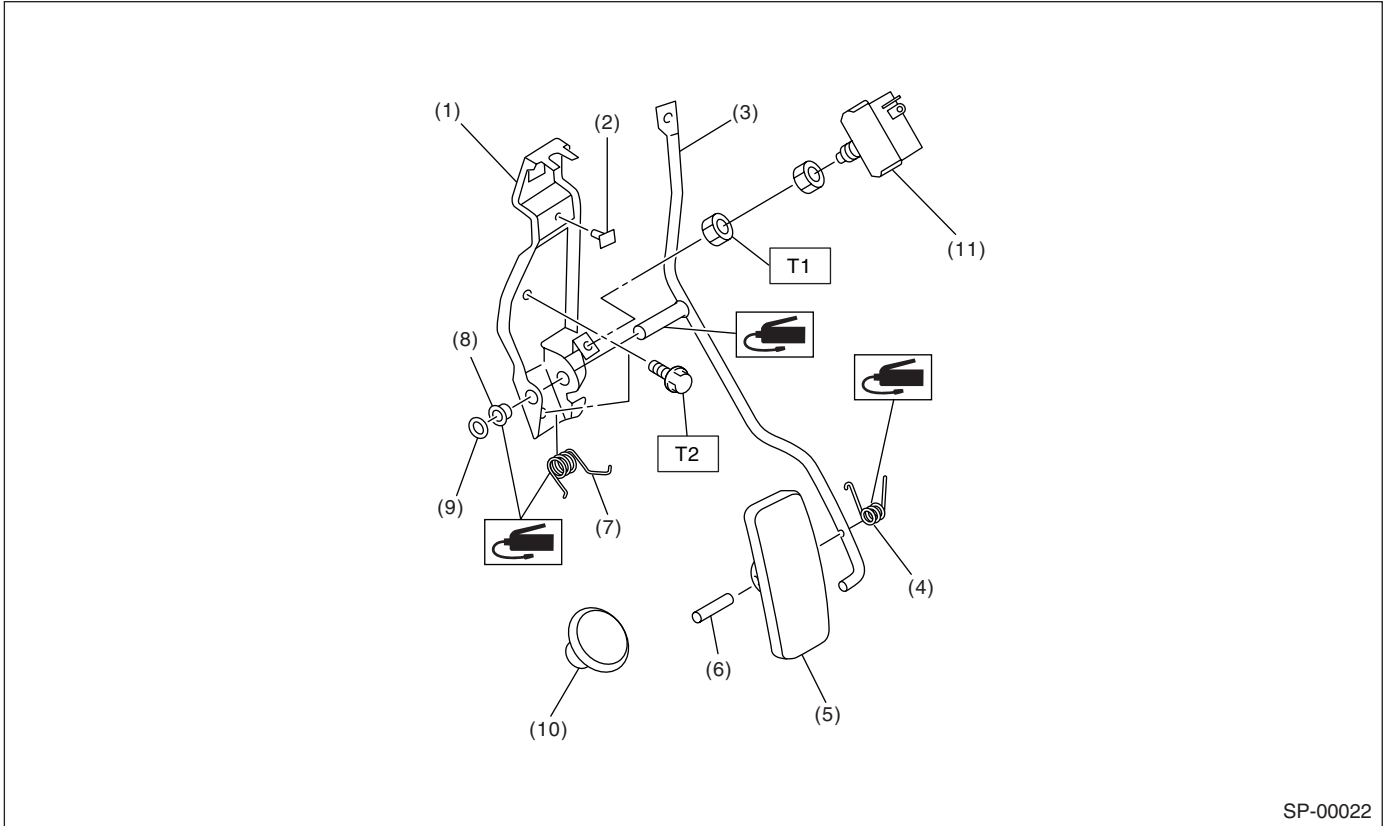

SP-00022

(1) Accelerator bracket

(2) Stopper

(3) Accelerator pedal lever

(4) Accelerator pedal spring

(5) Accelerator pedal

(6) Spring pin

(7) Accelerator spring

(8) Bushing

(9) Clip

(10) Accelerator stopper

(11) Kick-down switch (AT model)

Tightening torque: N·m (kgf·m, ft·lb)

T1: 12 (1.2, 9.0)

T2: 18 (1.8, 13.0)

C: CAUTION

- Wear work clothing, including a cap, protective goggles, and protective shoes during operation.
- Remove contamination, including dirt and corrosion, before removal, installation or disassembly.
- Keep the disassembled parts in order and protect them from dust and dirt.
- Before removal, installation or disassembly, be sure to clarify the failure. Avoid unnecessary removal, installation, disassembly, and replacement.
- Be careful not to burn yourself, because each part in the vehicle is hot after running.
- Be sure to tighten fasteners including bolts and nuts to the specified torque.
- Place shop jacks or rigid racks at the specified points.
- Before disconnecting electrical connectors of sensors or units, be sure to disconnect the ground cable from battery.

Accelerator Pedal

SPEED CONTROL SYSTEM

2. Accelerator Pedal

A: REMOVAL

- 1) Disconnect the ground cable from battery.
- 2) Remove the lock nut from accelerator cable bracket.
- 3) Separate the accelerator cable from bracket.
- 4) Remove the accelerator cable end from throttle cam.

NOTE:

Be careful not to kink the accelerator cable.

- Non-turbo model

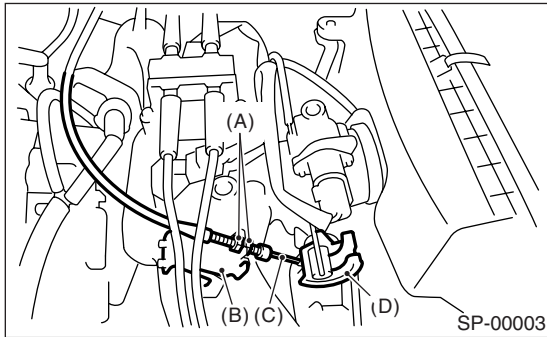

- Turbo model

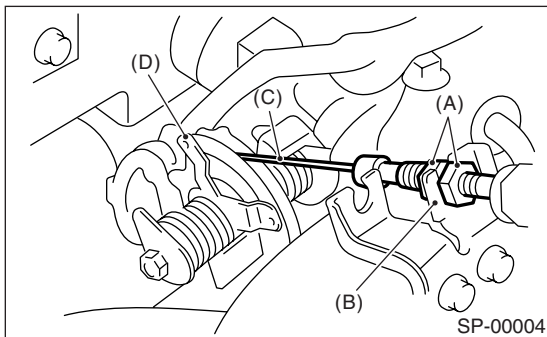

- (A) Lock nut
- (B) Accelerator cable bracket
- (C) Accelerator cable
- (D) Throttle cam

- 5) Remove the clip inside engine compartment.

- LHD Non-turbo model

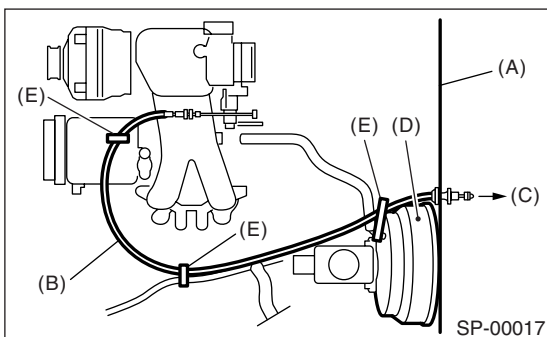

- RHD Non-turbo model

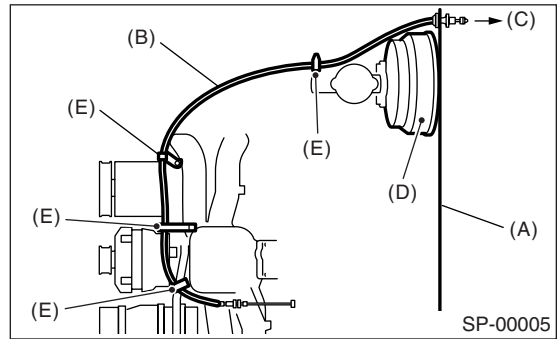

- LHD Turbo model

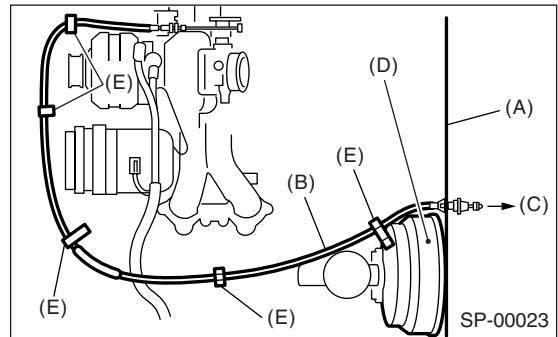

- RHD Turbo model

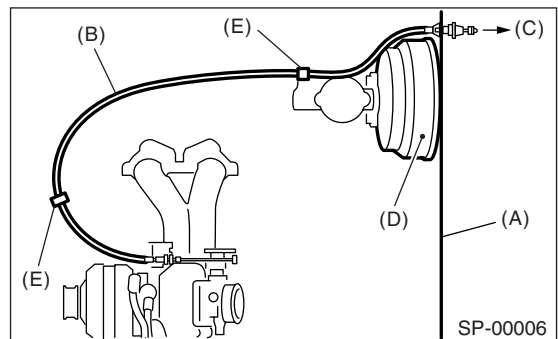

- (A) Toe board
- (B) Accelerator cable
- (C) To accelerator pedal
- (D) Brake booster
- (E) Clip

- 6) Remove the instrument panel lower cover from instrument panel, and connector.

- 7) Disconnect the connector from kick-down switch. (AT model)

Accelerator Pedal

8) Remove the accelerator pedal mounting bolt from accelerator pedal bracket.

- LHD model

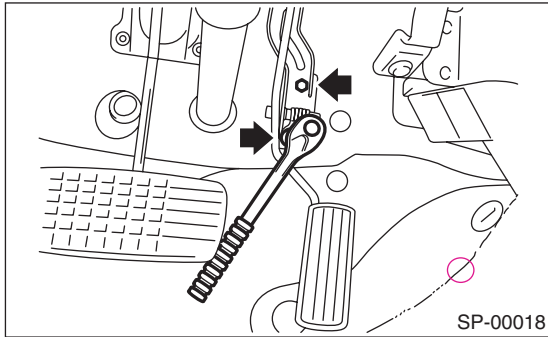

- RHD model

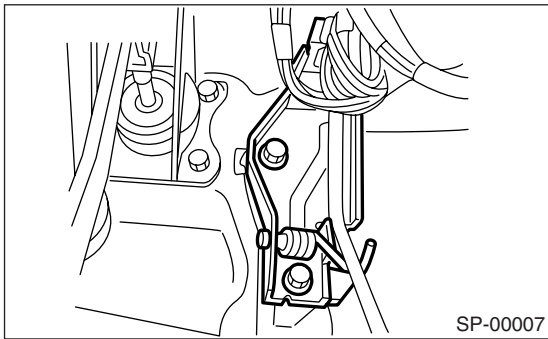

9) Disconnect the grommet from toe board.

NOTE:

From the inside compartment, push the grommet (A) into hole.

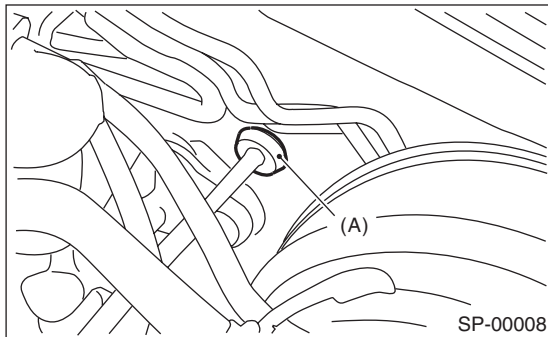

10) Pull out the cable from toe board hole.

11) Disconnect the accelerator cable bushing from accelerator pedal lever.

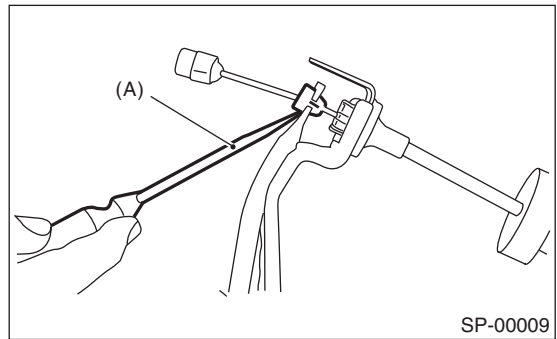

(A) Flat tip screwdriver

12) Disconnect the accelerator cable stopper (A) from bracket.

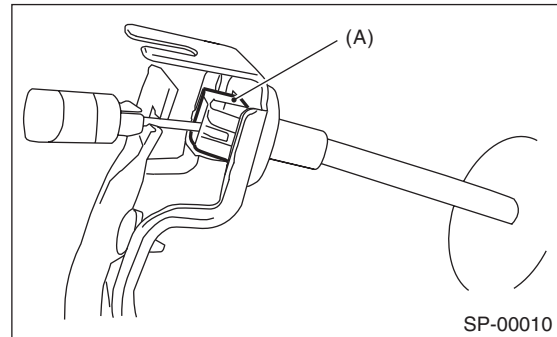

13) Separate the accelerator cable and accelerator bracket.

B: INSTALLATION

Install in the reverse order of removal.

NOTE:

- If the cable clamp is damaged, replace it with a new one.
- Never fail to cover the outer cable end with boot.
- Be careful not to kink the accelerator cable.
- For tightening torque, refer to "COMPONENT". <Ref. to SP(H4SO)-2, COMPONENT, General Description.>

Accelerator Pedal

SPEED CONTROL SYSTEM

C: DISASSEMBLY

- 1) Remove the clip, and then remove the accelerator pedal lever from accelerator bracket.
- 2) Pull out the spring pin, and then remove the accelerator pedal from accelerator pedal lever.

• LHD model

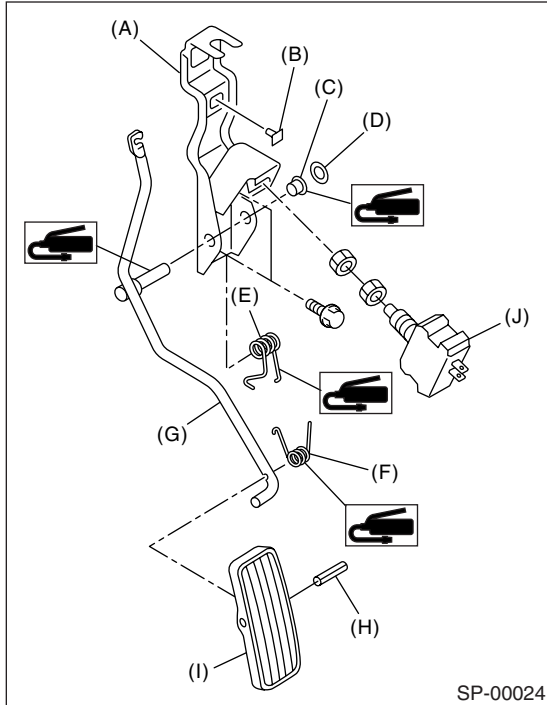

- (A) Accelerator bracket
- (B) Stopper
- (C) Bushing
- (D) Clip
- (E) Accelerator spring
- (F) Accelerator pedal spring
- (G) Accelerator pedal lever
- (H) Spring pin
- (I) Accelerator pedal
- (J) Kick-down switch (AT model)

• RHD model

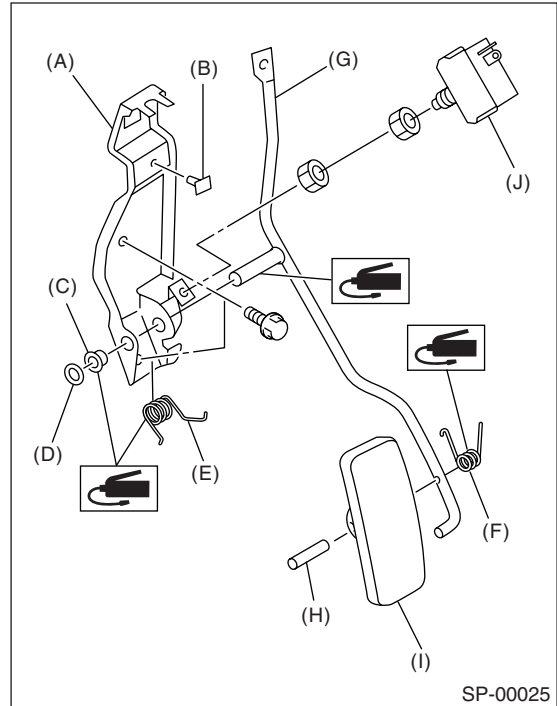

- (A) Accelerator bracket
- (B) Stopper
- (C) Bushing
- (D) Clip
- (E) Accelerator spring
- (F) Accelerator pedal spring
- (G) Accelerator pedal lever
- (H) Spring pin
- (I) Accelerator pedal
- (J) Kick-down switch (AT model)

D: ASSEMBLY

Assemble in the reverse order of disassembly.

NOTE:

Clean and apply grease to the portions indicated in the figure.

Grease:

SUNLIGHT No. 2 (Part No. 003602010)

E: INSPECTION

1. ACCELERATOR PEDAL

Lightly move the pedal pad in lateral direction to ensure that pedal deflection is in specified range.

CAUTION:

If excessive deflection is noted, replace the bushing and clip with new ones.

Deflection of accelerator pedal:
Service limit
 $\pm 2.0 \text{ mm } (\pm 0.079 \text{ in})$ or less

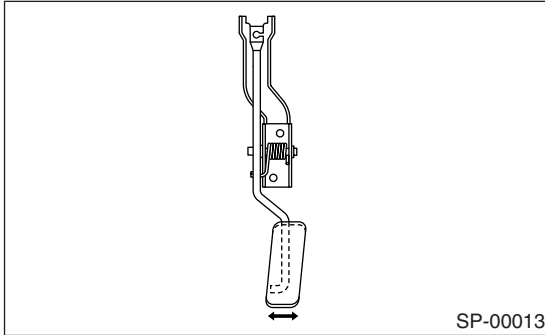

2. KICK-DOWN SWITCH

If the kick-down switch does not operate properly (or if it does not stop at the specified position), replace with a new one.

Specified position: A
 $2.0 - 3.5 \text{ mm } (0.079 - 0.098 \text{ in})$

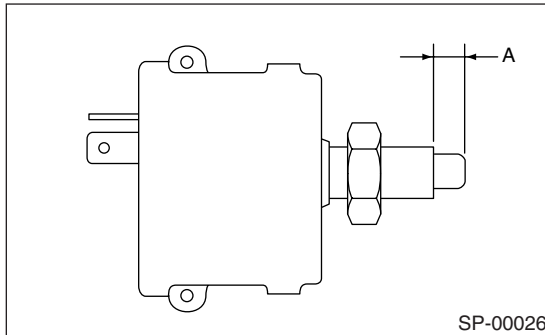

F: ADJUSTMENT

1) Check the pedal stroke and free play by operating accelerator pedal by hand.

2) If it is not within specified value, adjust it by turning the nut connecting the accelerator cable to throttle body.

Free play at pedal pad: L
 $0 - 4 \text{ mm } (0 - 0.16 \text{ in})$

Stroke at pedal pad: A
 $52 - 57 \text{ mm } (2.05 - 2.24 \text{ in})$

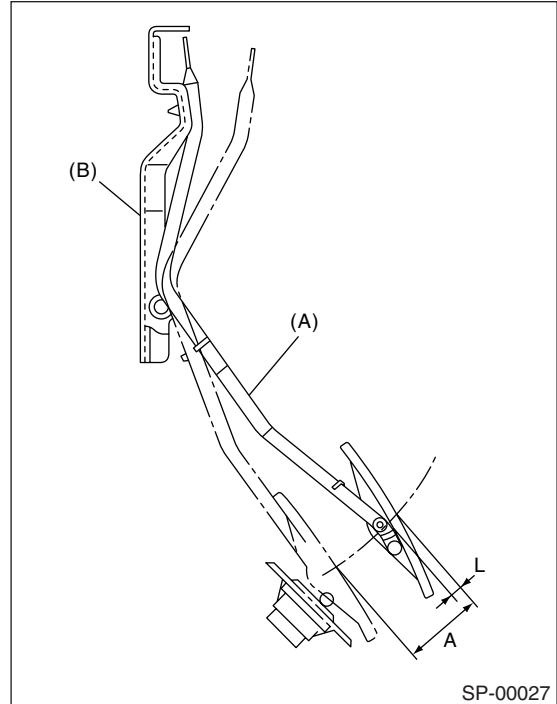

- (A) Accelerator pedal
- (B) Accelerator pedal bracket

Accelerator cable lock nut tightening torque:
 $12 \text{ N}\cdot\text{m } (1.2 \text{ kgf}\cdot\text{m}, 9 \text{ ft}\cdot\text{lb})$

3) Check to ensure the kick-down switch operates at the specified value in relation to the stroke of the accelerator pedal.

If it is not within specified value, adjust it by adjusting the position of kick-down switch.

CAUTION:

Be careful not to rotate the kick-down switch.

Kick-down switch stroke: L
 $47 - 49 \text{ mm } (1.85 - 1.93 \text{ in})$

Accelerator Pedal

SPEED CONTROL SYSTEM

**Kick-down switch tightening torque:
12 N·m (1.2 kgf-m, 9 ft-lb)**

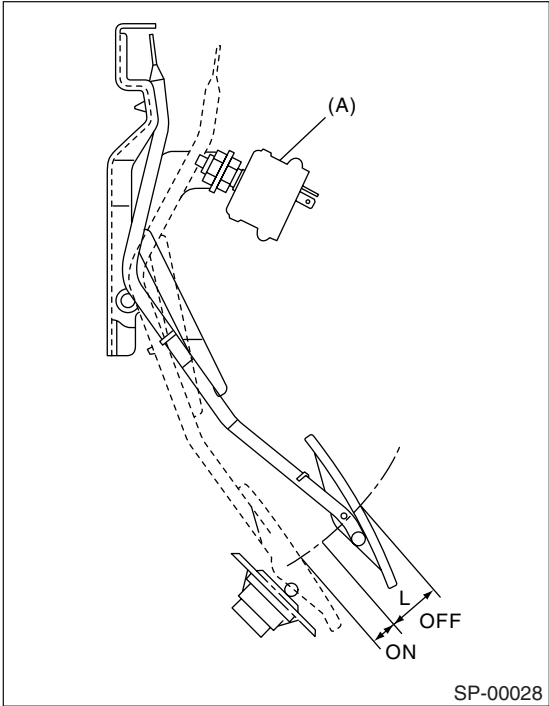

(A) Kick down switch

3. Accelerator Control Cable

A: REMOVAL

- 1) Remove the accelerator pedal. <Ref. to SP(H4SO)-4, REMOVAL, Accelerator Pedal.>
- 2) Separate the accelerator cable and accelerator pedal.

B: INSTALLATION

- 1) Install in the reverse order of removal.

NOTE:

- If the cable clamp is damaged, replace it with a new one.
- Never fail to cover the outer cable end with boot.
- Be careful not to kink the accelerator cable.

CAUTION:

Do not apply grease to except specified part.

- 2) Apply grease to engine side accelerator cable end.

Grease:

Slicolube G-30M (Part No. 004404002)

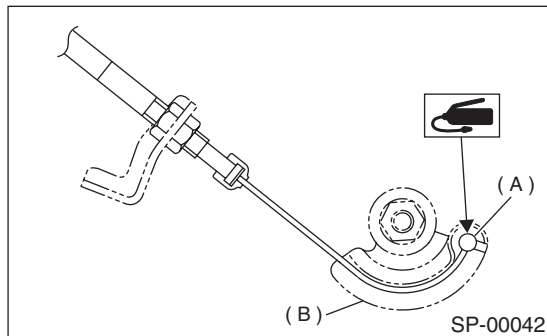

(A) Accelerator cable end

(B) Throttle cam

- 3) Adjustment after pedal installation. <Ref. to SP(H4SO)-7, ADJUSTMENT, Accelerator Pedal.>

C: INSPECTION

- 1) Make sure the inner cable is not twisted or worn.
- 2) Make sure the outer cable is not cracked.

