

WIRING SYSTEM SECTION

WIRING SYSTEM

WI

This service manual has been prepared to provide SUBARU service personnel with the necessary information and data for the correct maintenance and repair of SUBARU vehicles.

This manual includes the procedures for maintenance, disassembling, reassembling, inspection and adjustment of components and diagnostics for guidance of experienced mechanics.

Please peruse and utilize this manual fully to ensure complete repair work for satisfying our customers by keeping their vehicle in optimum condition. When replacement of parts during repair work is needed, be sure to use SUBARU genuine parts.

All information, illustration and specifications contained in this manual are based on the latest product information available at the time of publication approval.

WIRING SYSTEM



	Page
1. Basic Diagnostics Procedure	3
2. Working Precautions	14
3. Power Supply Routing.....	15
4. Ground Distribution	29
5. Airbag System.....	52
6. Air Conditioning System.....	58
7. Anti-lock Brake System	70
8. AT Control System	77
9. Audio System	101
10. Charging System.....	105
11. Combination Meter.....	106
12. Cruise Control System	110
13. Engine Electrical System	120
14. Fuel Gauge System	186
15. Full-Time Dual-Range System	188
16. Front Accessory Power Supply System	190
17. Headlight Beam Leveler System.....	191
18. Horn System	193
19. Immobilizer System.....	194
20. Door Lock System.....	198
21. Keyless Entry System	200
22. Back-up Light System	209
23. Clearance Light and Illumination Light System	210
24. Front Fog Light System.....	219
25. Headlight System	221
26. Headlight Washer System.....	223
27. In Compartment Light System.....	224
28. Stop Light System	228
29. Turn Signal Light and Hazard Light System.....	229
30. Oil Pressure Warning Light System	233
31. Rear Differential Oil Temperature Warning Light System	235
32. Outside Temperature Display System	236
33. Parking Brake and Brake Fluid Level Warning System	238
34. Power Window System	240
35. Radiator Fan System	248
36. Rear Fog Light System	249
37. Rear Window Defogger System.....	251
38. Remote Controlled Rearview Mirror System.....	253
39. Seat Belt Warning System	255
40. Seat Heater System	257
41. Security System	259
42. Starter System	261
43. Sunroof System.....	263

WIRING SYSTEM

44.	Wiper and Washer System (Front).....	264
45.	Wiper and Washer System (Rear)	265
46.	Rear Accessory Power Supply System.....	266
47.	Wiper Deicer System (Rear)	267
48.	Harness Components Location.....	268
49.	Front Wiring Harness	270
50.	Bulkhead Wiring Harness (In Engine Room)	274
51.	Bulkhead Wiring Harness (In Compartment)	282
52.	Engine Wiring Harness and Transmission Cord	288
53.	Instrument Panel Wiring Harness	292
54.	Rear Wiring Harness, Bulkhead Wiring Harness, Roof Cord and Fuel Tank Cord.....	296
55.	Door Cord.....	302
56.	Rear Wiring Harness and Rear Gate Cord	306

1. Basic Diagnostics Procedure

A: BASIC PROCEDURES

1. GENERAL

The most important purpose of diagnostics is to determine which part is malfunctioning quickly, to save time and labor.

2. IDENTIFICATION OF TROUBLE SYMPTOM

Determine what the problem is based on symptom.

3. PROBABLE CAUSE OF TROUBLE

Look at the wiring diagram and check system's circuit. Then check the switch, relay, fuse, ground, etc.

4. LOCATION AND REPAIR OF TROUBLE

- 1) Using the diagnostics narrow down the causes.
- 2) If necessary, use a voltmeter, ohmmeter, etc.
- 3) Before replacing certain component parts (switch, relay, etc.), check the power supply, ground, for open wiring harness, poor connectors, etc. If no problems are encountered, check the component parts.

5. CONFIRMATION OF SYSTEM OPERATION

After repairing, ensure that the system operates properly.

B: BASIC INSPECTION

1. VOLTAGE MEASUREMENT

1) Using a voltmeter, connect the negative lead to a good ground point or negative battery terminal and the positive lead to the connector or component terminal.

2) Contact the positive probe of the voltmeter on connector (A).

The voltmeter will indicate a voltage.

3) Shift the positive probe to connector (B). The voltmeter will indicate no voltage.

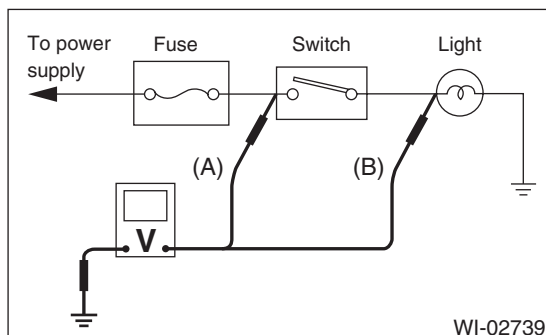

4) With test set-up held as it is, turn the switch ON. The voltmeter will indicate a voltage and, at the same time, the light will come on.

5) The circuit is in good order. If a problem such as a lamp failing to light occurs, use the procedures outlined above to track down malfunction.

2. CIRCUIT CONTINUITY CHECKS

1) Disconnect the battery cable or connector so there is no voltage between check points.

Contact the two leads of an ohmmeter to each of the check points.

If the circuit has diodes, reverse the two leads and check again.

2) Use an ohmmeter to check for the diode continuity. When contacting the negative lead to diode positive side and positive lead to negative side, there should be continuity.

When contacting the two leads in reverse, there should be no continuity.

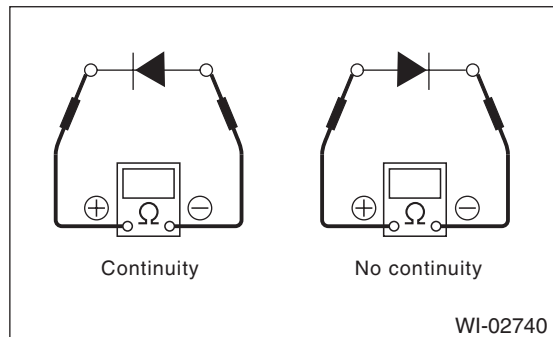

3) Symbol "○—○" indicates that continuity exists between two points or terminals. For example, when a switch position is "3", continuity exists among terminals 1, 3 and 6, as shown in table below.

Terminal Switch Position	1	2	3	4	5	6
OFF						
1	○—○				○—○	
2	○—○			○—○		○—○
3	○—○		○—○			○—○
4	○—○	○—○				○—○

WI-02741

Basic Diagnostics Procedure

WIRING SYSTEM

3. HOW TO DETERMINE AN OPEN CIRCUIT

1) Voltmeter Method:

An open circuit is determined by measuring the voltage between respective connectors and ground using a voltmeter, starting with the connector closest to power supply. The power supply must be turned ON so that current flows in the circuit. If voltage is not present between a particular connector and ground, the circuit between that connector and previous connector is open.

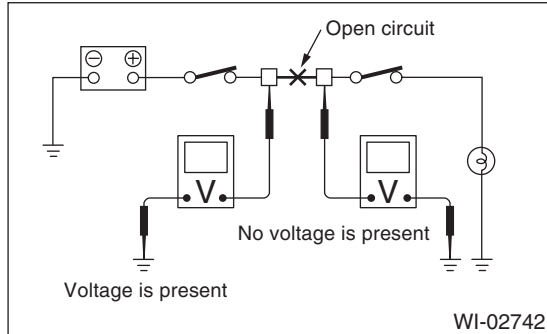

2) Ohmmeter method:

Disconnect all connectors affected, and check the continuity in wiring between adjacent connectors. When the ohmmeter indicates "infinite", the wiring is open.

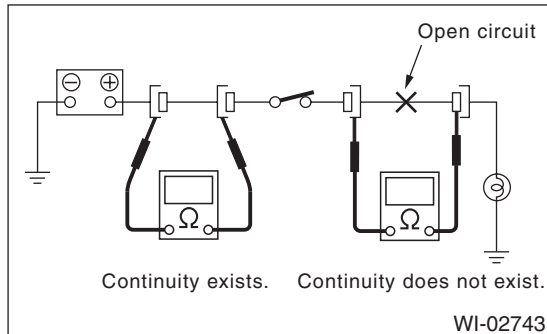

4. HOW TO DETERMINE A SHORT CIRCUIT

1) Test lamp method:

Connect a test lamp (rated at approx. 3 watts) in place of the blown fuse and allow current to flow through the circuit. Disconnect one connector at a time from the circuit, starting with the one located farthest from power supply. If the test lamp goes out when a connector is disconnected, the wiring

between that connection and next connector (farther from the power supply) is shorted.

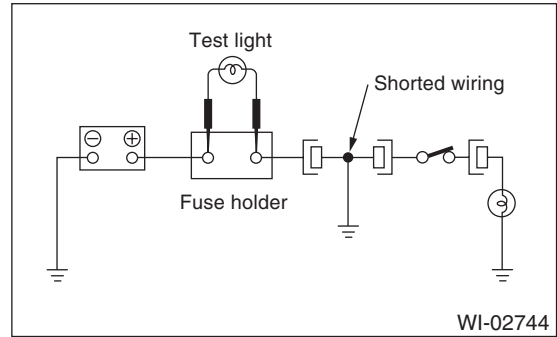

2) Ohmmeter method:

Disconnect all affected connectors, and check the continuity between each connector and ground. When the ohmmeter indicates continuity between a particular connector and ground, that the connector is shorted.

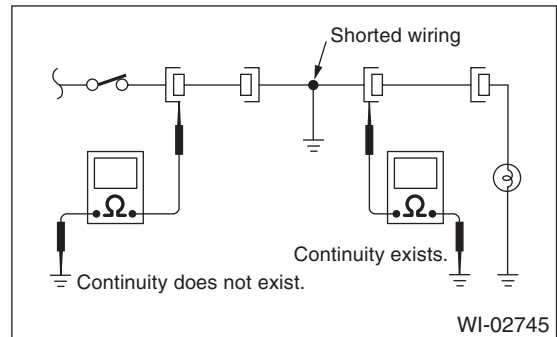

C: HOW TO READ WIRING DIAGRAMS

1. WIRING DIAGRAM

The wiring diagram of each system is illustrated so that you can understand the path through which electric current flows from battery.

Sketches and codes are used in the diagrams. They should read as follows:

- Each connector and its terminal position are indicated by a sketch of the connector in a disconnected state which is viewed from front.

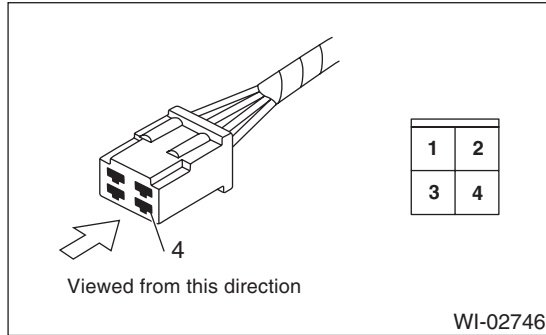

- The number of poles or pins, presence of a lock, and pin number of each terminal are indicated in the sketch of each connector. In the sketch, the highest pole number refers to the number of poles which connector has. For example, the sketch of connector shown in the figure indicates the connector has 9 poles.

Connector used in vehicle	Connector shown in wiring diagram										
	Sketch	Symbol	Number of poles								
	<p>Double frames</p> <p>Indicates a lock is included.</p> <table border="1"> <tr> <td>4</td> <td>3</td> <td>2</td> <td>1</td> </tr> <tr> <td>9</td> <td>8</td> <td>7</td> <td>6</td> </tr> </table> <p>Indicates the number of poles.</p>	4	3	2	1	9	8	7	6		<p>Numbered in order from upper right to lower left.</p>
4	3	2	1								
9	8	7	6								
	<p>Indicates a lock is included.</p> <table border="1"> <tr> <td>1</td> <td>2</td> <td>3</td> <td>4</td> </tr> <tr> <td>5</td> <td>6</td> <td>7</td> <td>8</td> </tr> </table> <p>Single frame</p>	1	2	3	4	5	6	7	8		<p>Numbered in order from upper left to lower right</p>
1	2	3	4								
5	6	7	8								

WI-02747

Basic Diagnostics Procedure

WIRING SYSTEM

- When one set of connectors is viewed from the front side, the pole numbers of one connector are symmetrical to those of other. When these two connectors are connected as a unit, the poles which have the same number are joined.

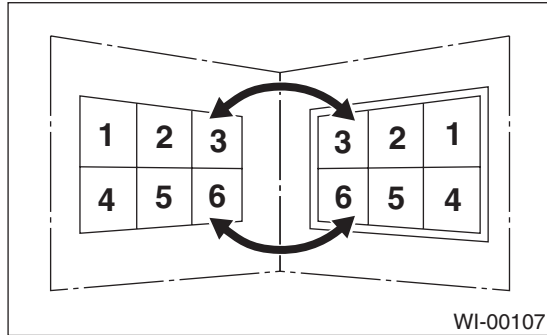

- Electrical wiring harness:**
The connectors are numbered along with the number of poles, external colors, and mating connections in accompanying list.
- The sketch of each connector in the wiring diagram usually shows (A) side of the connector. The relationship between wire color, terminal number and connector is described in figure.

NOTE:

A wire which runs in one direction from a connector terminal sometimes may have a different color from that which runs in the other direction from that terminal.

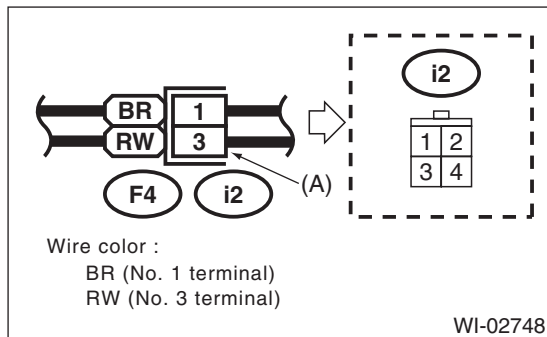

- In wiring diagram, connectors which have no terminal number refer to one-pole types. Sketches of these connectors are omitted intentionally.

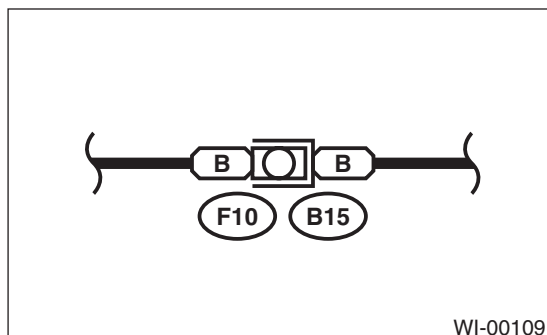

- The following color codes are used to indicate the colors of the wires used.

Color code	Color
L	Blue
B	Black
Y	Yellow
G	Green
R	Red
W	White
Br	Brown
Lg	Light green
Gr	Gray
P	Pink
Or	Orange
Lb	Light Blue
V	Violet
SA	Sealed (Inner)
SB	Sealed (Outer)

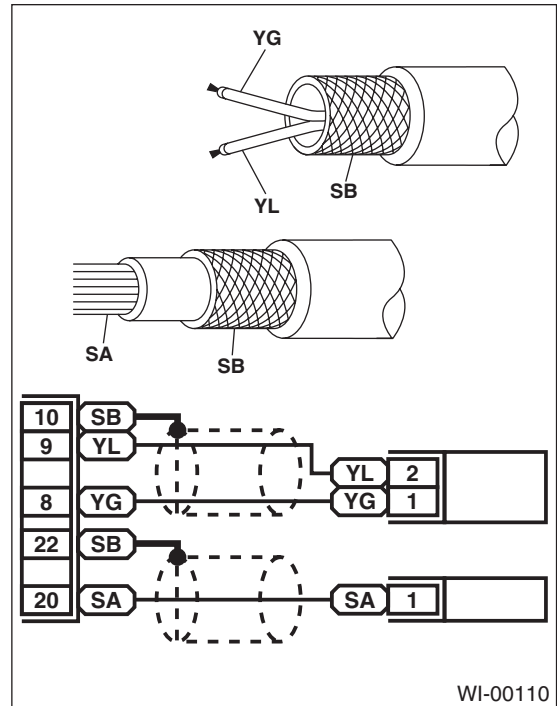

- The wire color code, which consists of two letters (or three letters including Br or Lg), indicates the standard color (base color of the wire covering) by its first letter and stripe marking by its second or third letter.

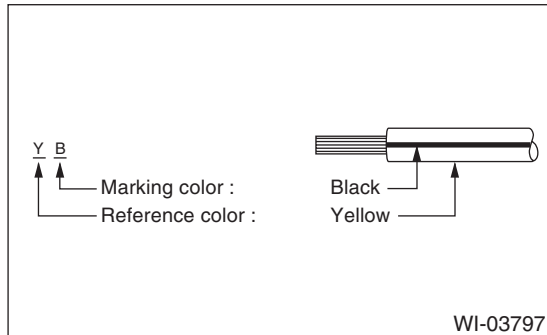

- The table lists the nominal sectional areas and allowable currents of wires.

CAUTION:

When replacing or repairing a wire, be sure to use the same size and type of wire which was originally used.

NOTE:

- The allowable current in the table indicates tolerable amperage of each wire at an ambient temperature of 40°C (104°F).
- The allowable current changes with ambient temperature. Also, it changes if a bundle of more than two wires is used.

Nominal sectional area mm ²	No. of strands/ strand diameter	Outside diameter of finished wiring mm	Allowable current Amps/ 40°C (104°F)
0.3	7/0.26	1.8	7
0.5	7/0.32	2.2 (or 2.0)	12
0.75	30/0.18	2.6 (or 2.4)	16
0.85	11/0.32	2.4 (or 2.2)	16
1.25	16/0.32	2.7 (or 2.5)	21
2	26/0.32	3.1 (or 2.9)	28
3	41/0.32	3.8 (or 3.6)	38
5	65/0.32	4.6 (or 4.4)	51
8	50/0.45	5.5	67

- Each unit is directly grounded to the body or indirectly grounds through a harness ground terminal. Different symbols are used in the wiring diagram to identify the two grounding systems.

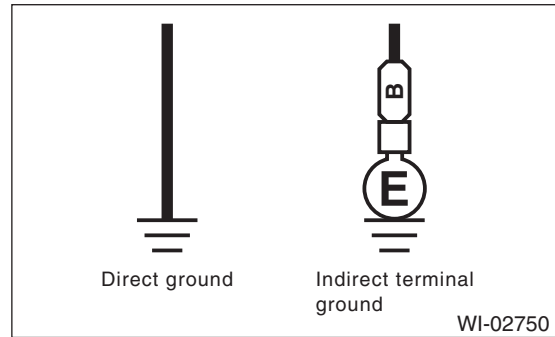

- The ground points shown in the wiring diagram refer to the following:

NOTE:

All wiring harnesses are provided with a ground point which should be securely connected.

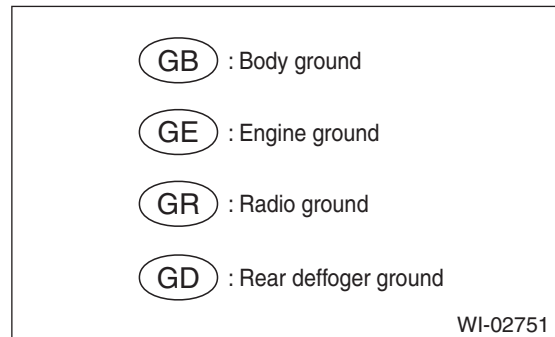

- Relays are classified as normally-open or normally-closed. The normally-closed relay has one or more contacts.

Basic Diagnostics Procedure

WIRING SYSTEM

The wiring diagram shows the relay mode when energizing circuit is OFF.

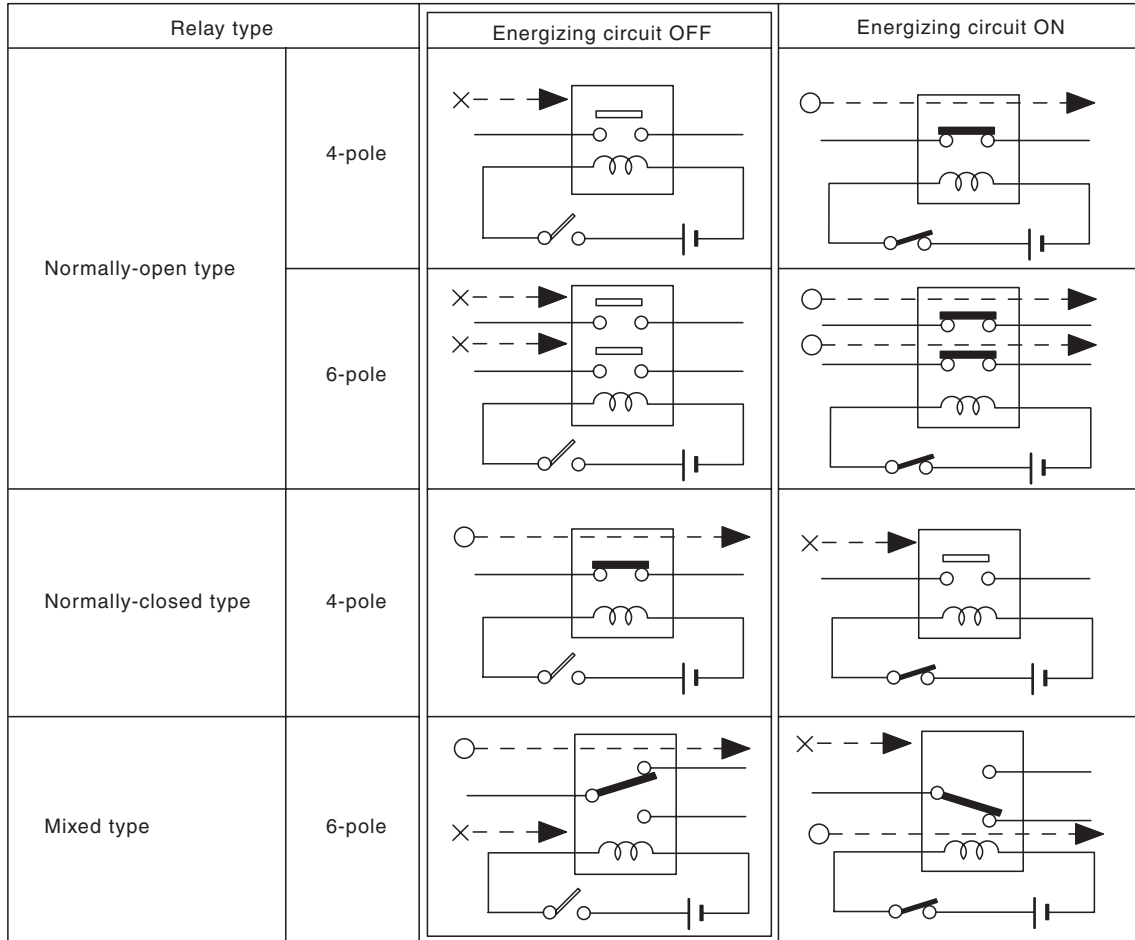

Key to symbols:

○ —▶ : Current flows.

× —▶ : Current does not flow.

WI-02752

- Each connector number shown in the wiring diagram corresponds to that in wiring harness. The location of each connector in actual vehicle is determined by reading the first character of the connector (for example, a "F" for F8, "i" for i16, etc.) and type of wiring harness.

The first character of each connector number refers to the area or system of the vehicle.

Symbol	Wiring harness and cord
F	Front wiring harness
B	Bulkhead wiring harness
E	Engine wiring harness
T	Transmission cord, Rear oxygen sensor cord
D	Door cord LH & RH, Rear door cord LH & RH, Rear gate cord
i	Instrument panel wiring harness
R	Rear wiring harness, Fuel tank cord, Roof cord
AB	Airbag wiring harness

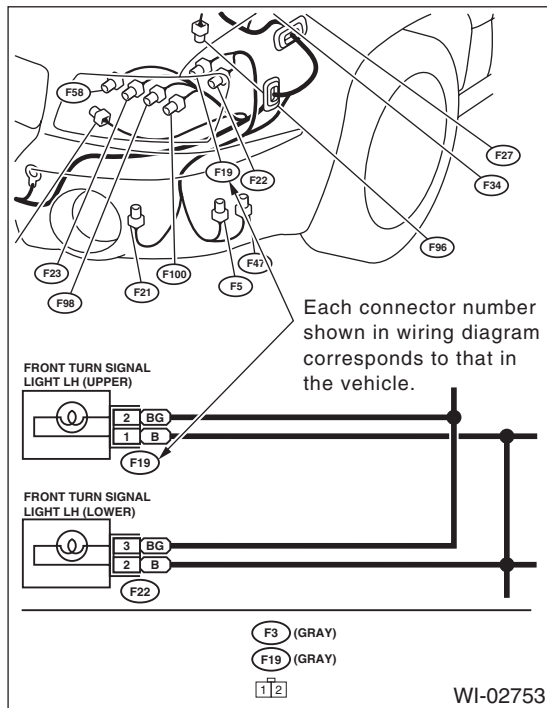

Basic Diagnostics Procedure

WIRING SYSTEM

D: SYMBOLS IN WIRING DIAGRAMS

A number of symbols are used in each wiring diagram to easily identify parts or circuits.

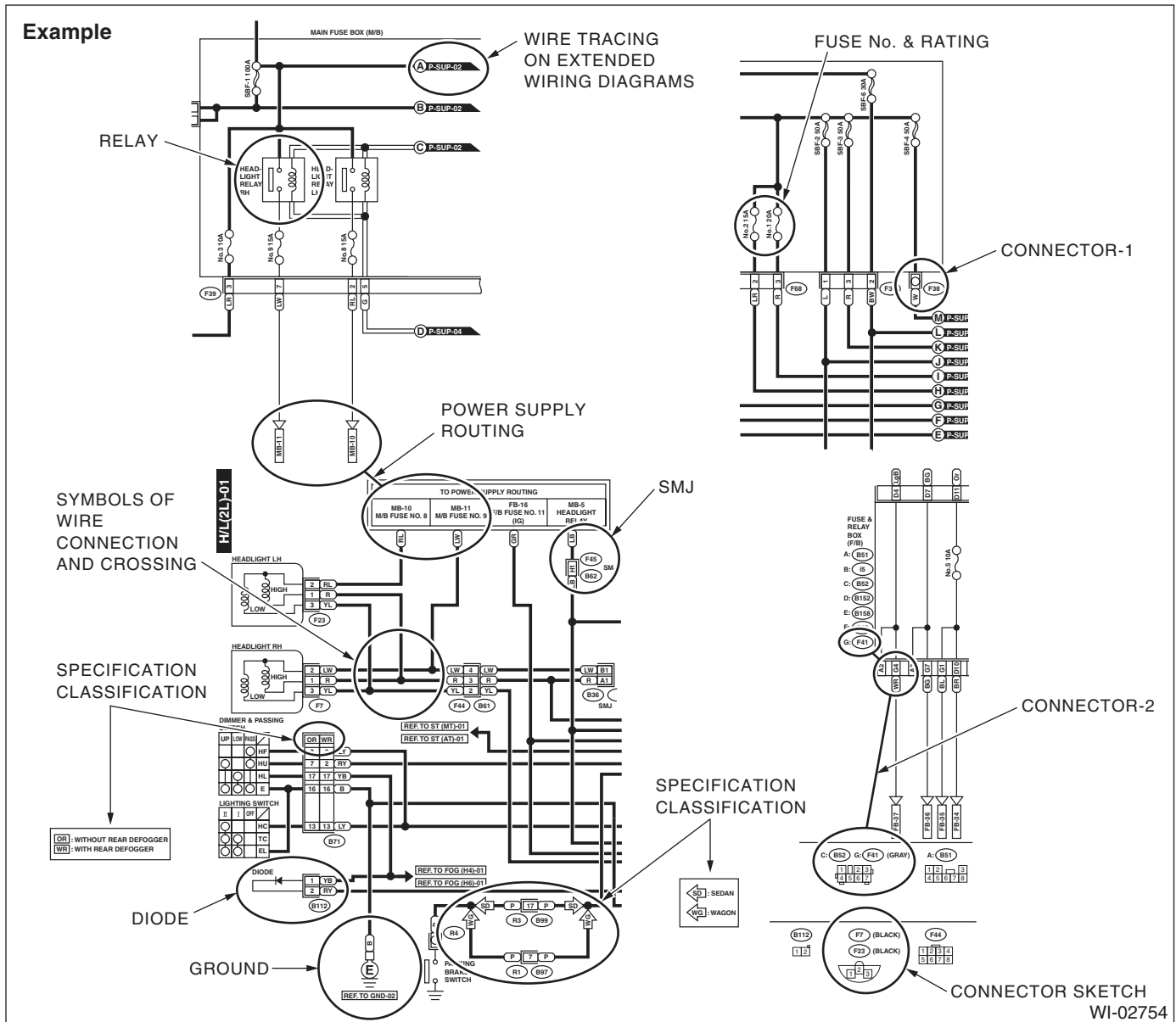

1. RELAY

A symbol used to indicate a relay.

2. CONNECTOR-1

The sketch of the connector indicates one-pole types.

3. WIRING CONNECTION

Some wiring diagrams are indicated in foldouts for convenience. Wiring destinations are indicated where necessary by corresponding symbols (as when two pages are needed for clear indication).

4. FUSE NO. & RATING

The "FUSE No. & RATING" corresponds with that used in fuse box (main fuse box, fuse and joint box).

5. CONNECTOR-2

- Each connector is indicated by a symbol.
- Each terminal number is indicated in the corresponding wiring diagram in an abbreviated form.
- For example, terminal number "G4" refers to No. 4 terminal of connector (G: F41) shown in the connector sketch.

6. CONNECTOR SKETCH

- Each connector sketch clearly identifies the shape and color of a connector as well as terminal locations. Non-colored connectors are indicated in natural color.
- When more than two types of connector number are indicated in a connector sketch, it means that the same type connectors are used.

7. GROUND

Each grounding point can be located easily by referring to the corresponding wiring harness.

8. DIODE

A symbol is used to indicate a diode.

9. WIRE TRACING ON EXTENDED WIRING DIAGRAMS

For a wiring diagram extending over at least two pages, a symbol (consisting of the same characters with arrows), facilitates wire tracing from one page to the next.

A ↔ A, B ↔ B

10. SYMBOLS OF WIRE CONNECTION AND CROSSING

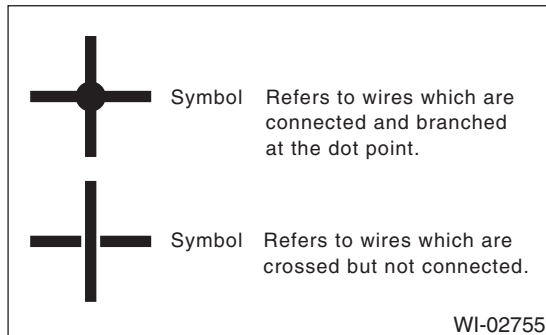

11. POWER SUPPLY ROUTING

A symbol is used to indicate the power supply in each wiring diagram.

“MB-5”, “MB-6”, etc., which are used as power supply symbols throughout the text, correspond with those shown in POWER SUPPLY ROUTING in the wiring diagram.

Accordingly, using the POWER SUPPLY ROUTING and wiring diagrams permits service personnel to understand the entire electrical arrangement of a system.

12. CLASSIFICATION BY SPECIFICATION

When the wiring diagrams differ according to vehicle specifications, the specification difference is described by using abbreviations.









The difference among destinations indicates by option code (EK, EC, etc.). Option code is described on model number plate in engine compartment. <Ref. to ID-5, MODEL NUMBER PLATE, IDENTIFICATION, Identification.>



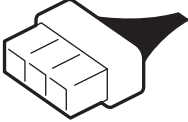

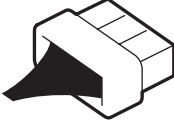
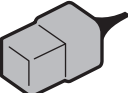
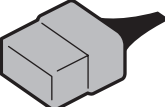
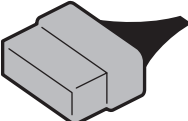





Basic Diagnostics Procedure

WIRING SYSTEM

E: CONNECTOR SYMBOL IN WIRING HARNESS

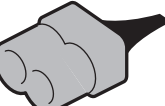
Main symbols of connector (in wiring harness) are indicated in below.

Standard type: Female		
Pole: From 1 to 8	Pole: From 9 to 20	Pole: More than 21
		
		
Standard type: Male		
		
		

Water proof type: Female		
Pole: From 1 to 8	Pole: From 9 to 20	Pole: More than 21
		
		
Water proof type: Male		
		
		

WI-02445

F: ABBREVIATION IN WIRING DIAGRAMS

Abbreviation	Full name
ABS	Antilock Brake System
ACC	Accessory
A/C	Air Conditioning
AD	Auto Down
AT	Automatic Transmission
AU	Auto Up
+B	Battery
DN	Down
E	Ground
F/B	Fuse & Joint Box
FL1.5	Fusible link 1.5 mm ²
IG	Ignition
Illumi.	Illumination
LH	Left Hand
Lo	Low
M	Motor
M/B	Main Fuse Box
MG	Magnet
Mi	Middle
OP	Optional Parts
PASS	Passing
RH	Right Hand
SBF	Slow Blow Fuse
ST	Starter
SW	Switch
TGV	Tumble Generated Valve
UP	Up
WASH	Washer

2. Working Precautions

A: PRECAUTIONS WHEN WORKING WITH THE PARTS MOUNTED ON THE VEHICLE

- 1) When working under a vehicle which is jacked-up, always be sure to use rigid racks.
- 2) The parking brake must always be applied during working. Also, in automatic transmission models, keep the select lever set to P (Parking) range.
- 3) Be sure the workshop is properly ventilated when running the engine. Further, be careful not to touch the belt or fan while the engine is operating.
- 4) Be careful not to touch hot metal parts, especially the radiator and exhaust system immediately after the engine has been shut off.

B: PRECAUTIONS IN TROUBLE DIAGNOSIS AND REPAIR OF ELECTRIC PARTS

- 1) The battery cable must be disconnected from battery's (-) terminal, and the ignition switch must be set to OFF position, unless otherwise required by the diagnostics.
- 2) Securely fasten the wiring harness with clamps and clips so that the harness does not interfere with body end parts or edges and bolts or screws.
- 3) When installing the parts, be careful not to catch them on the wiring harness.
- 4) When disconnecting a connector, do not pull the wires, but pull while holding the connector body.

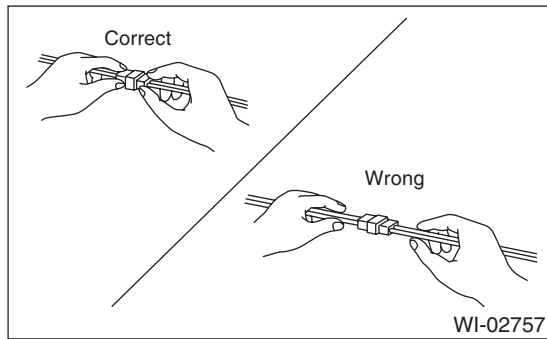

- 5) Some connectors are provided with a lock. One type of such a connector is disconnected by pushing the lock, and the other, by moving the lock up. In either type the lock shape must be identified before attempting to disconnect the connector.

To connect, insert the connector until it snaps and confirm that it is tightly connected.

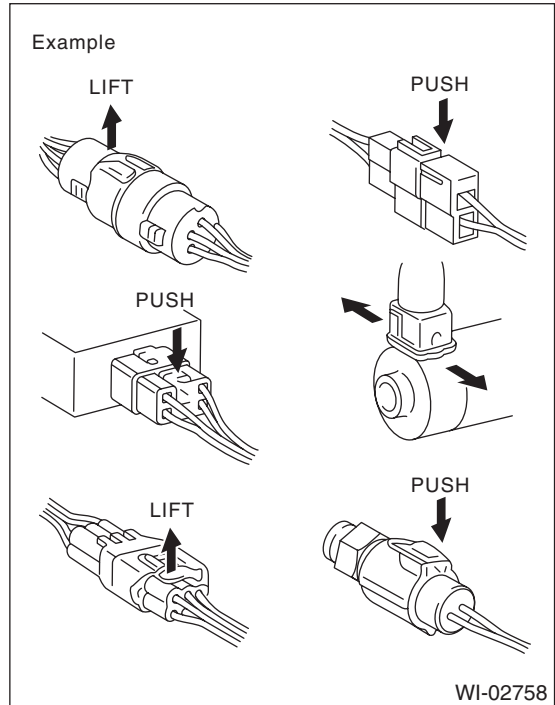

- 6) When checking continuity between connector terminals, or measuring the voltage across the terminal and ground, always contact tester probe(s) on terminals from the wiring connection side. If the probe is too thick to gain access to the terminal, use "mini" test leads.

To check water-proof connectors (which are not accessible from the wiring side), contact test probes on the terminal side being careful not to bend or damage terminals.

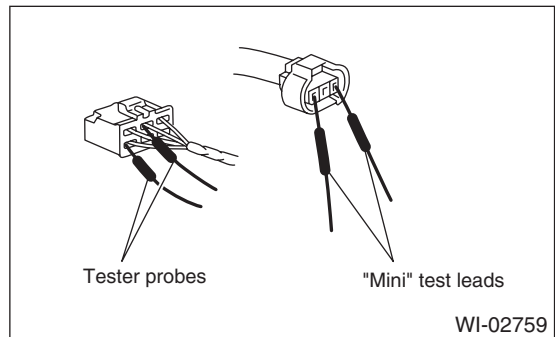

- 7) Sensors, relays, electrical unit, etc., are sensitive to strong impacts. Handle them with care so that they are not dropped or mishandled.

3. Power Supply Routing

A: WIRING DIAGRAM

1. LHD MODEL

P-SUP(L)-01

P-SUP(L)-01

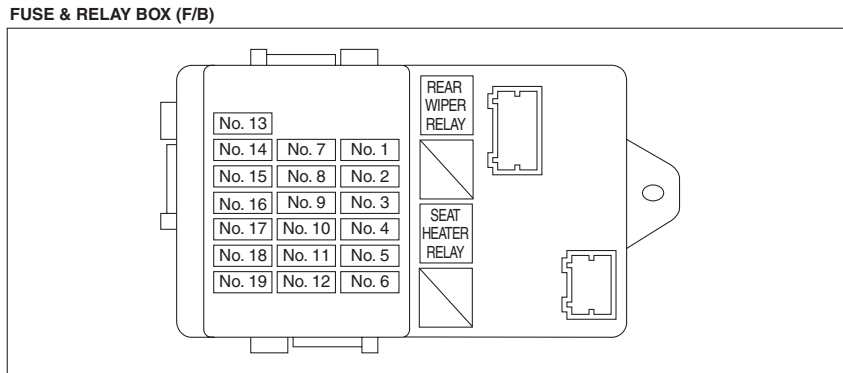
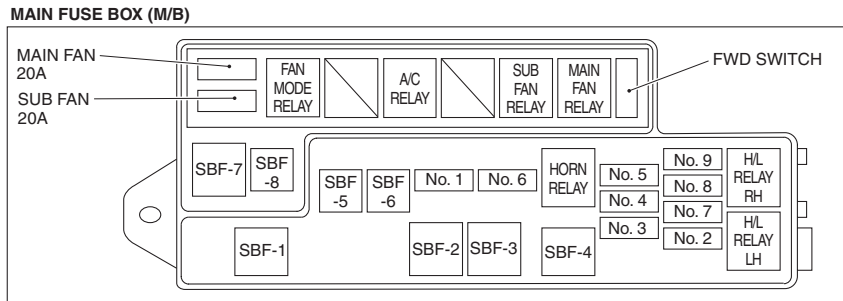

Power Supply Routing

WIRING SYSTEM

P-SUP(L)-02

P-SUP(L)-02

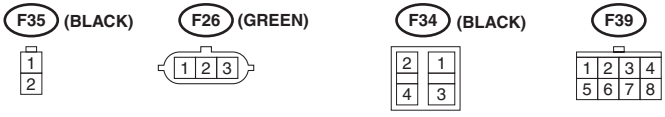
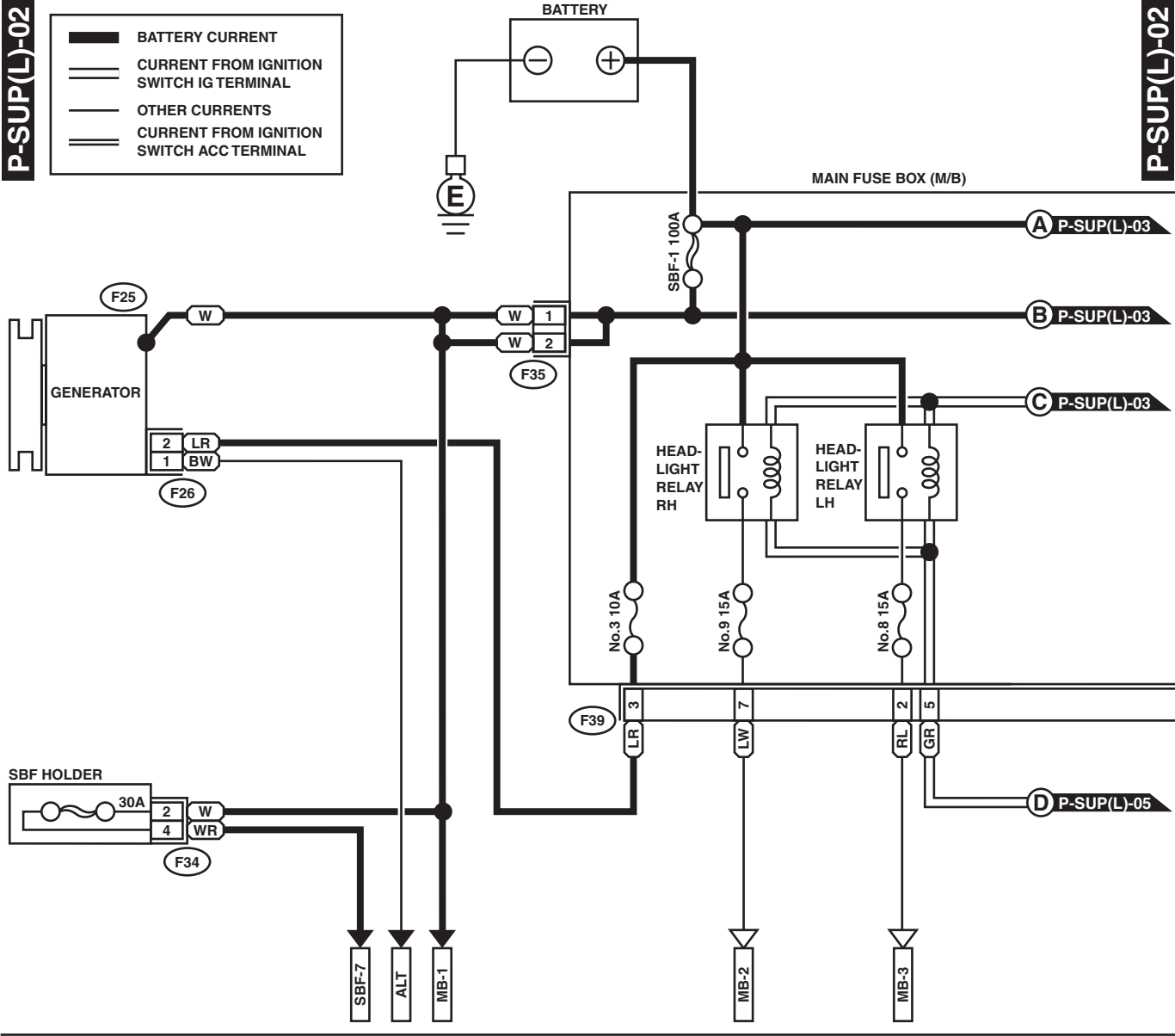
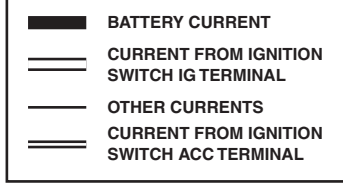

WI-00225

Power Supply Routing

WIRING SYSTEM

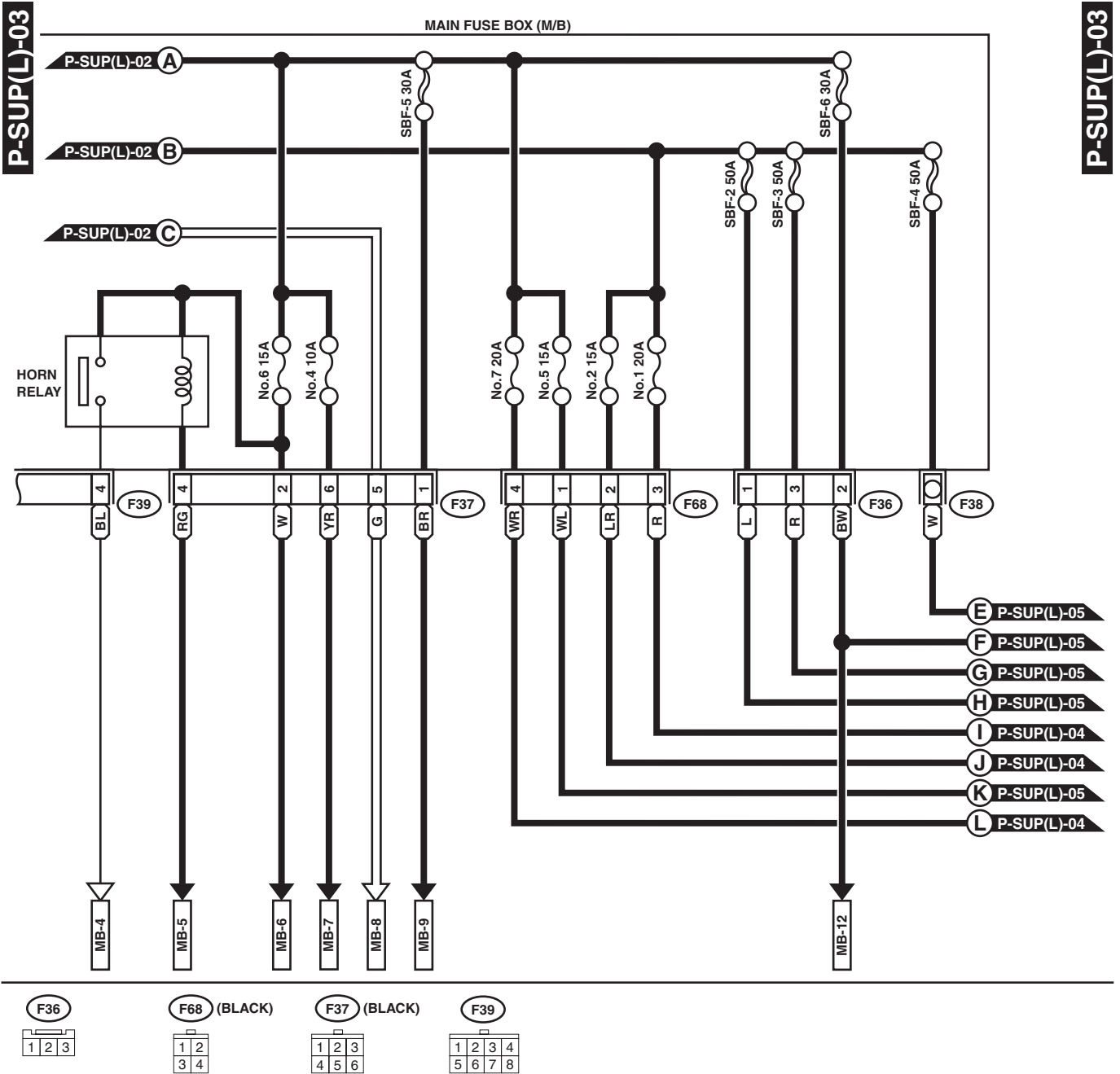

WI-00226

Power Supply Routing

WIRING SYSTEM

P-SUP(L)-04

P-SUP(L)-04

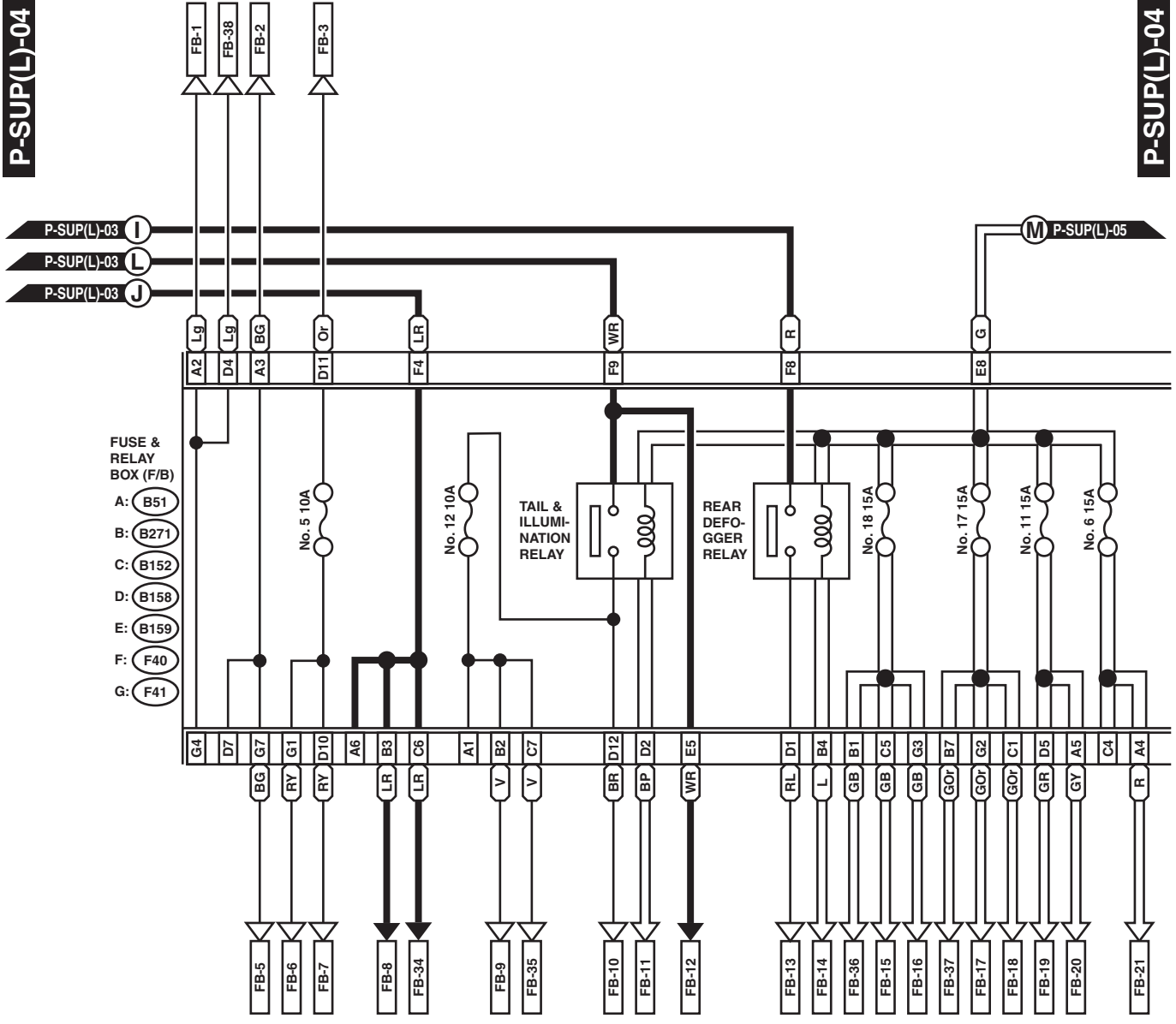

C: B152

A: B51 (BLUE)

F: F40 (BROWN)

E: B159 (GRAY)

B: B271 (BLUE)

G: F41 (GRAY)

1	2	3
4	5	6
7	8	

1	2	3	4
5	6	7	8
9			

1	2	3	4	5
6	7	8	9	10

D: B158

1	2	3	4	5
6	7	8	9	10
11	12			

1	2	3
4	5	6
7		

WI-03183

Power Supply Routing

WIRING SYSTEM

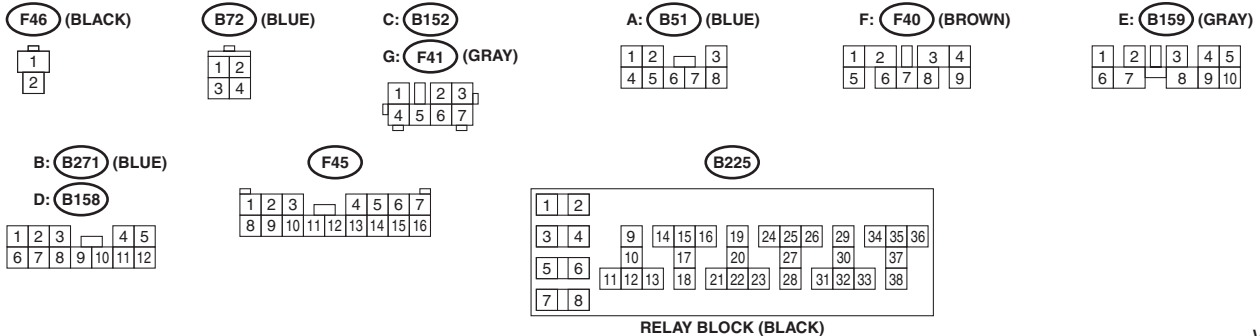
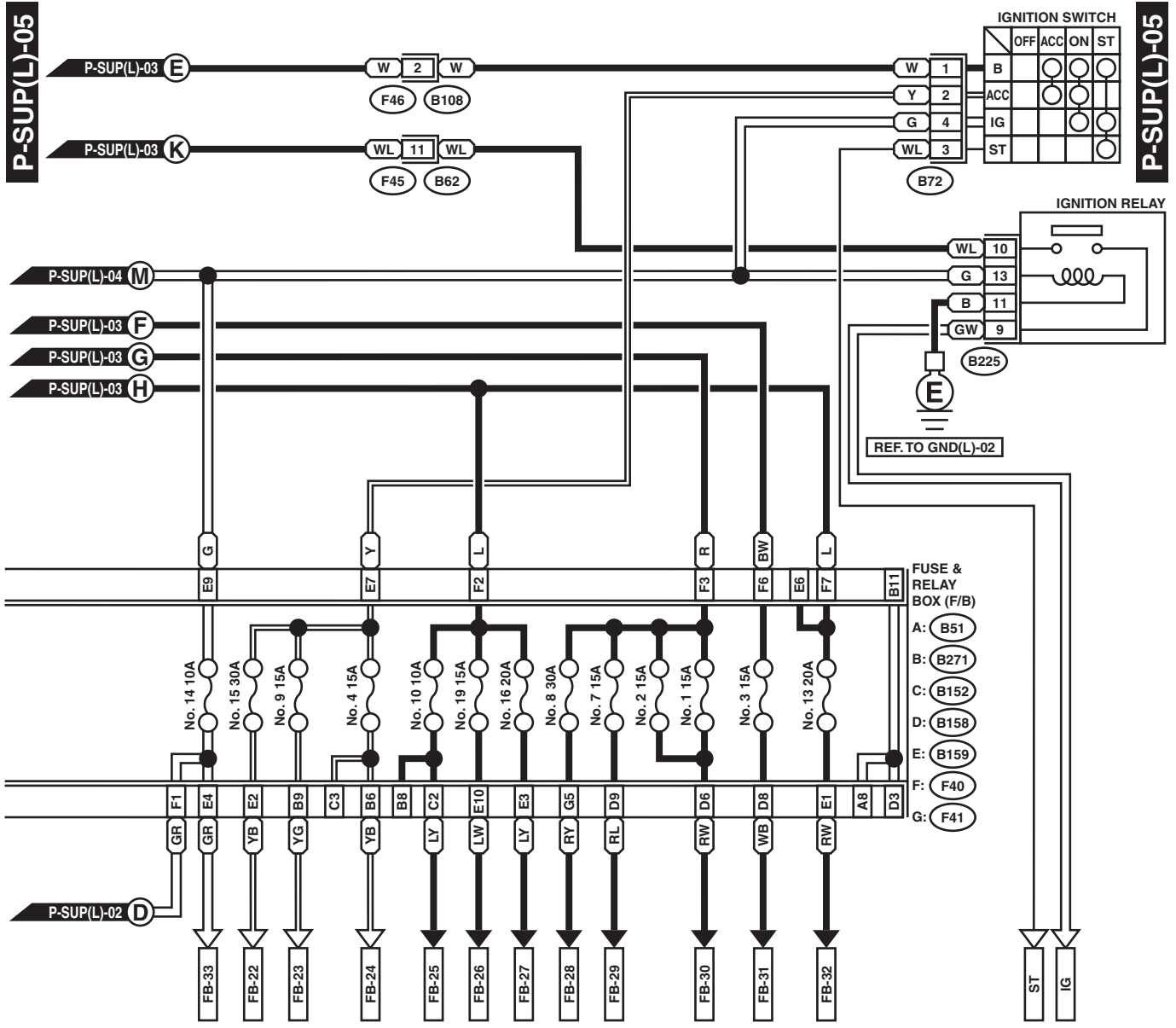

WI-03184

Power Supply Routing

WIRING SYSTEM

No.	Load
MB-1	Air conditioning relay holder
MB-2	Combination meter Headlight RH
MB-3	Headlight LH
MB-4	Horn
MB-5	Horn switch
MB-6	Hazard switch Keyless entry control module Key warning switch
MB-7	Transmission control module
MB-8	Diode (With rear fog light model) Lighting switch
MB-9	Data link connector Engine control module Fuel pump relay Immobilizer control module Main relay
MB-12	Headlight washer module Power window circuit breaker
SBF-7	ABS control module
ALT-1	Combination meter
ALT-2	Engine control module
IG	Hazard switch Check connector Headlight washer switch Ignition relay Vehicle speed sensor (MT model) Power window relay
ST	Engine control module Cruise control module Ignition switch Inhibitor switch (AT model) Starter motor (MT model)
FB-1	ABS condenser Combination meter Brake fluid level warning switch OP connector Parking switch
FB-2	Hazard switch Combination meter Rear turn signal light LH Trailer connector Keyless entry control module Turn signal switch
FB-3	Parking switch
FB-5	Front turn signal light LH Side turn signal light LH
FB-6	Headlight leveler LH Headlight leveler RH
FB-7	License plate light Front clearance light RH Rear combination light LH Rear combination light RH Trailer connector

No.	Load
FB-8	Auto A/C control module Radio Clock Combination meter Luggage room light Room light Spot map light Trailer connector
FB-9	Combination meter Radio CD illumination light
FB-10	Parking switch
FB-11	Engine control module Lighting switch
FB-12	Parking switch
FB-13	Auto A/C control module Rear defogger A/C switch
FB-14	Rear defogger timer
FB-15	Back light switch (MT model) Cruise control main switch Cruise control module Inhibitor switch (AT model) Seat belt timer Clutch switch (MT model)
FB-16	Main fan relay 1
FB-17	Main fan relay 2 Sub fan relay A/C relay Heater cock solenoid (2.0 L Non-turbo model)
FB-18	FRESH/RECIRC actuator Wiper deicer switch Rear defogger timer
FB-19	Engine control module Fuel pump relay Ignition coil and ignitor Immobilizer control module Transmission control module
FB-20	Airbag control module
FB-21	Airbag control module
FB-22	Front washer motor Front wiper motor Front wiper switch
FB-23	Clock Radio
FB-24	Front accessory power supply socket Rear accessory power supply socket Transmission control module (Turbo model) Remote controlled rearview mirror switch OP connector Seat heater relay
FB-25	Rear fog light relay
FB-26	Rear accessory power supply socket
FB-27	Stop light switch
FB-28	ABS control module
FB-29	Front fog light relay
FB-30	Blower motor relay

Power Supply Routing

WIRING SYSTEM

No.	Load
FB-31	Keyless entry control module OP connector
FB-32	Wiper deicer & Mirror heater relay
FB-33	Combination meter
FB-34	Keyless entry control module Ignition switch Illumination light
FB-35	At power mode & Hold mode switch Select lever illumination light Cruise control main switch Front accessory power supply socket Front fog light relay Front fog light switch Headlight leveler switch Headlight washer switch Lighting switch OP connector Rear fog light relay Glove box illumination light (Turbo model) Rear fog light switch Wiper deicer switch
FB-36	ABS control module Wiper deicer & Mirror heater relay
FB-37	A/C switch Blower fan motor relay Auto A/C control module
FB-38	ABS control module

Power Supply Routing

WIRING SYSTEM

2. RHD MODEL

P-SUP(R)-01

P-SUP(R)-01

MAIN FUSE BOX (M/B)

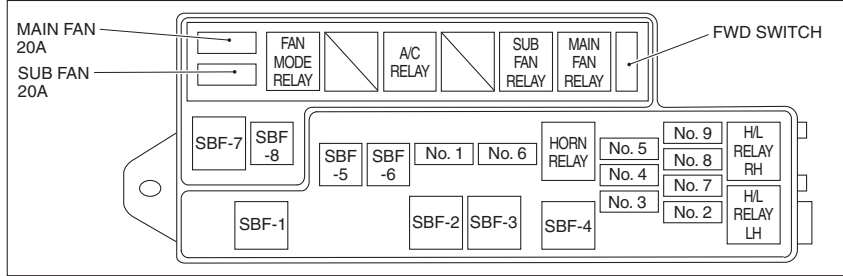

FUSE & RELAY BOX (F/B)

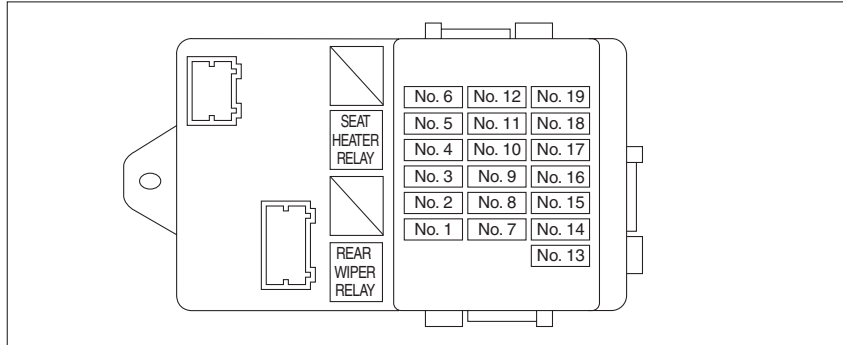

WI-00229

Power Supply Routing

WIRING SYSTEM

P-SUP(R)-02

P-SUP(R)-02

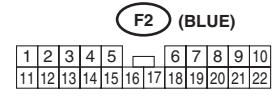
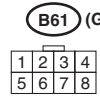
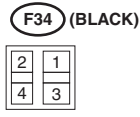
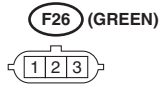
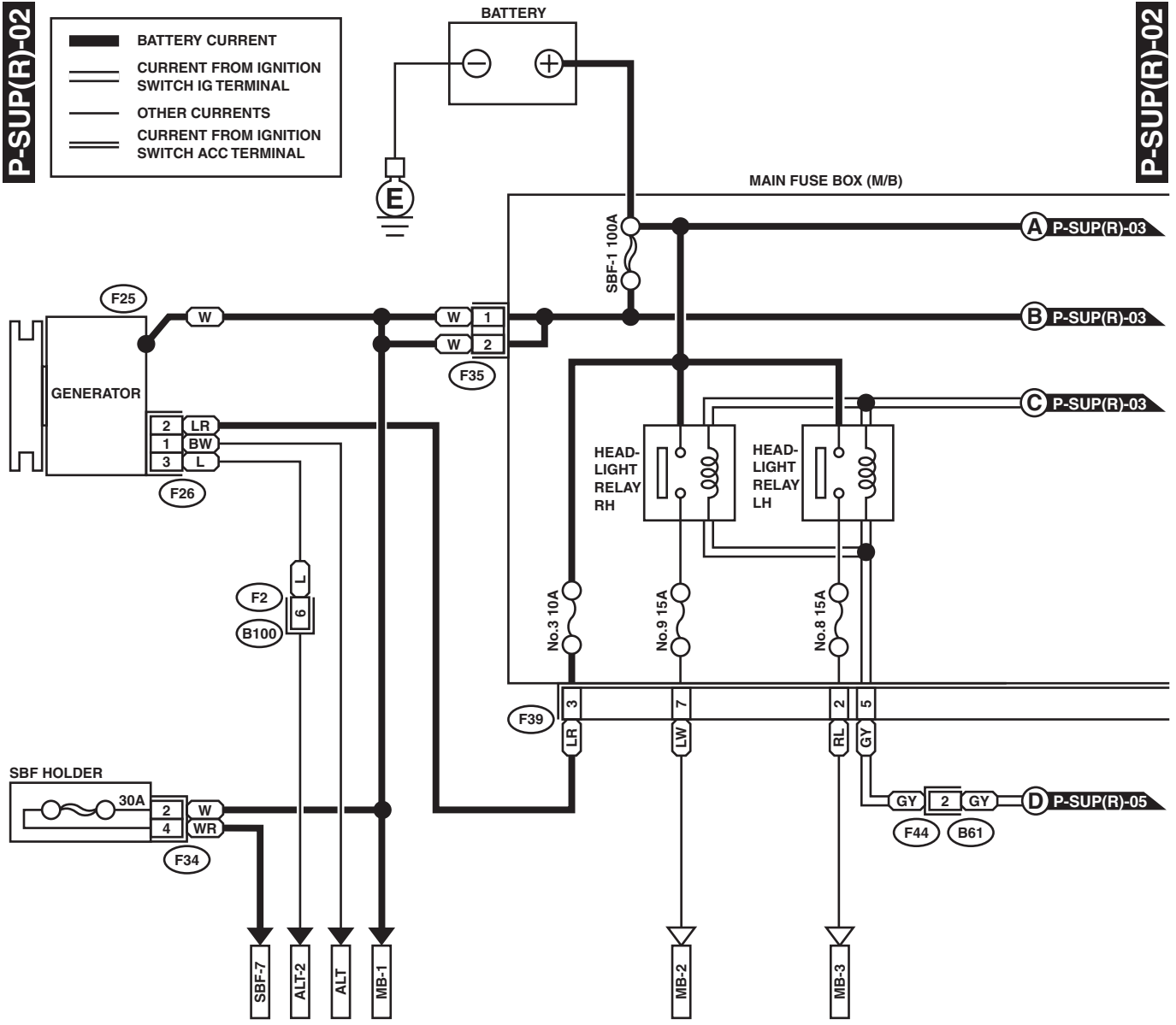
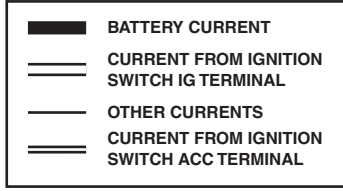

WI-00230

Power Supply Routing

WIRING SYSTEM

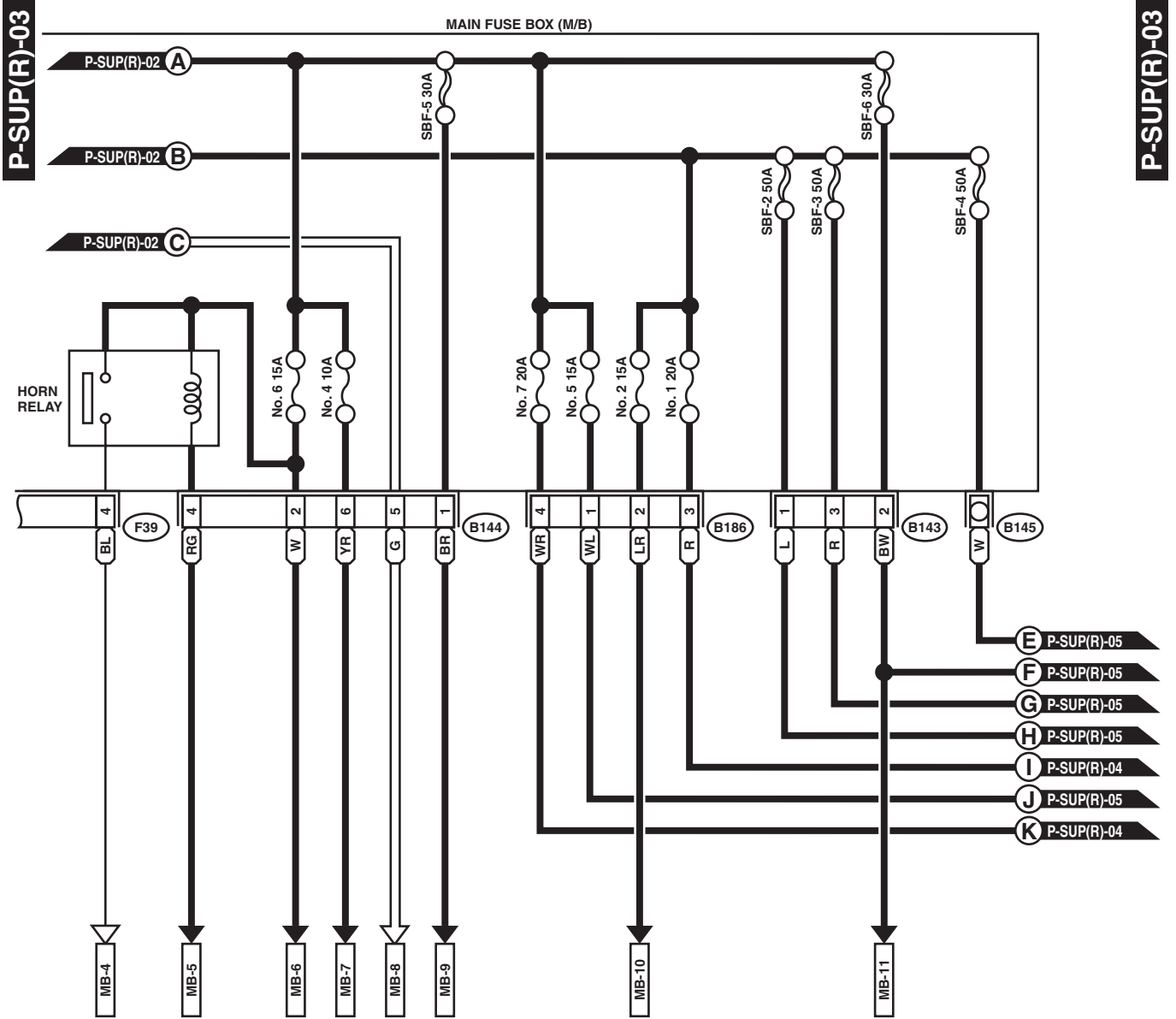

(B143)

1	2	3
---	---	---

(B186) (BLACK)

1	2
3	4

(B144) (BLACK)

1	2	3
4	5	6

(F39) (BLACK)

1	2	3	4
5	6	7	8

WI-00231

Power Supply Routing

WIRING SYSTEM

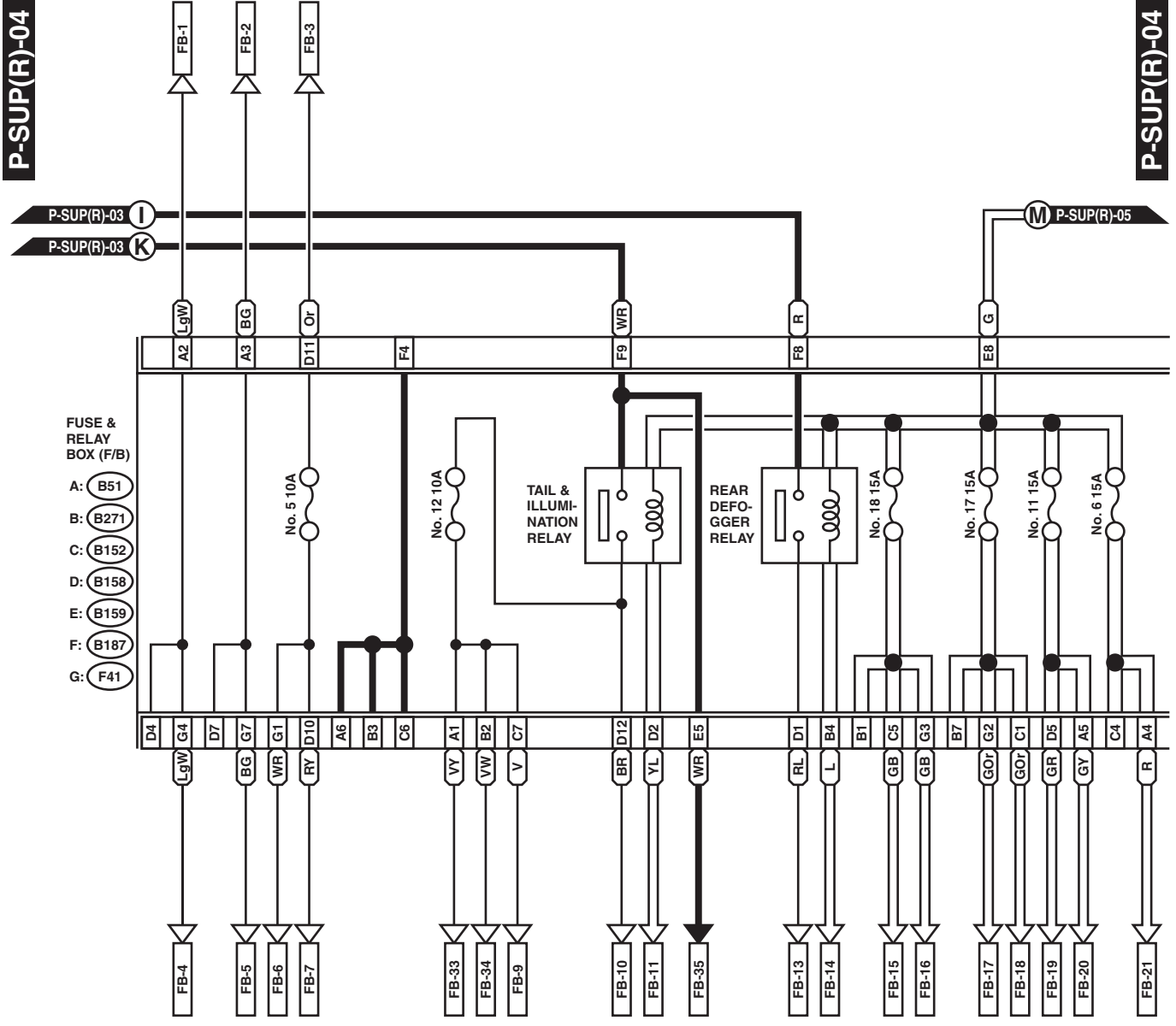

C: B152

G: F41 (GRAY)

1	2	3
4	5	6

A: B51 (BLUE)

1	2	3
4	5	6

F: B187 (BROWN)

1	2	3	4
5	6	7	8

E: B159 (GRAY)

1	2	3	4	5
6	7	8	9	10

B: B271 (BLUE)

D: B158

1	2	3	4	5
6	7	8	9	10

WI-00232

Power Supply Routing

WIRING SYSTEM

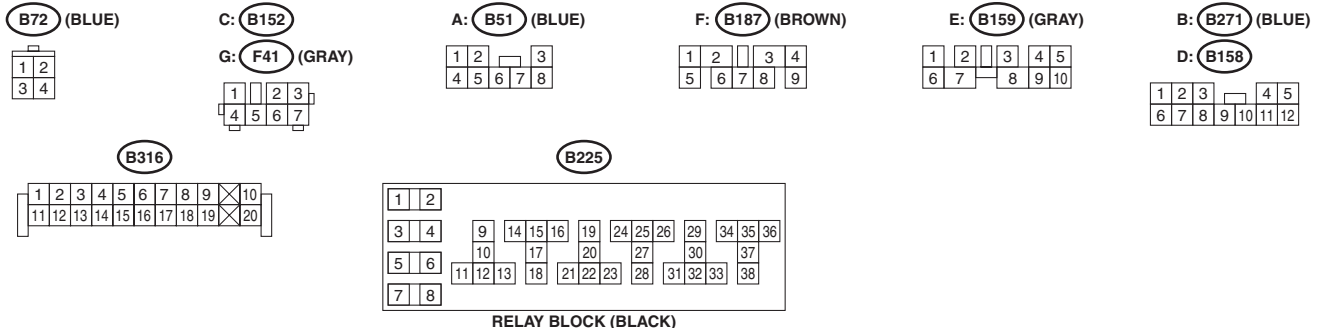
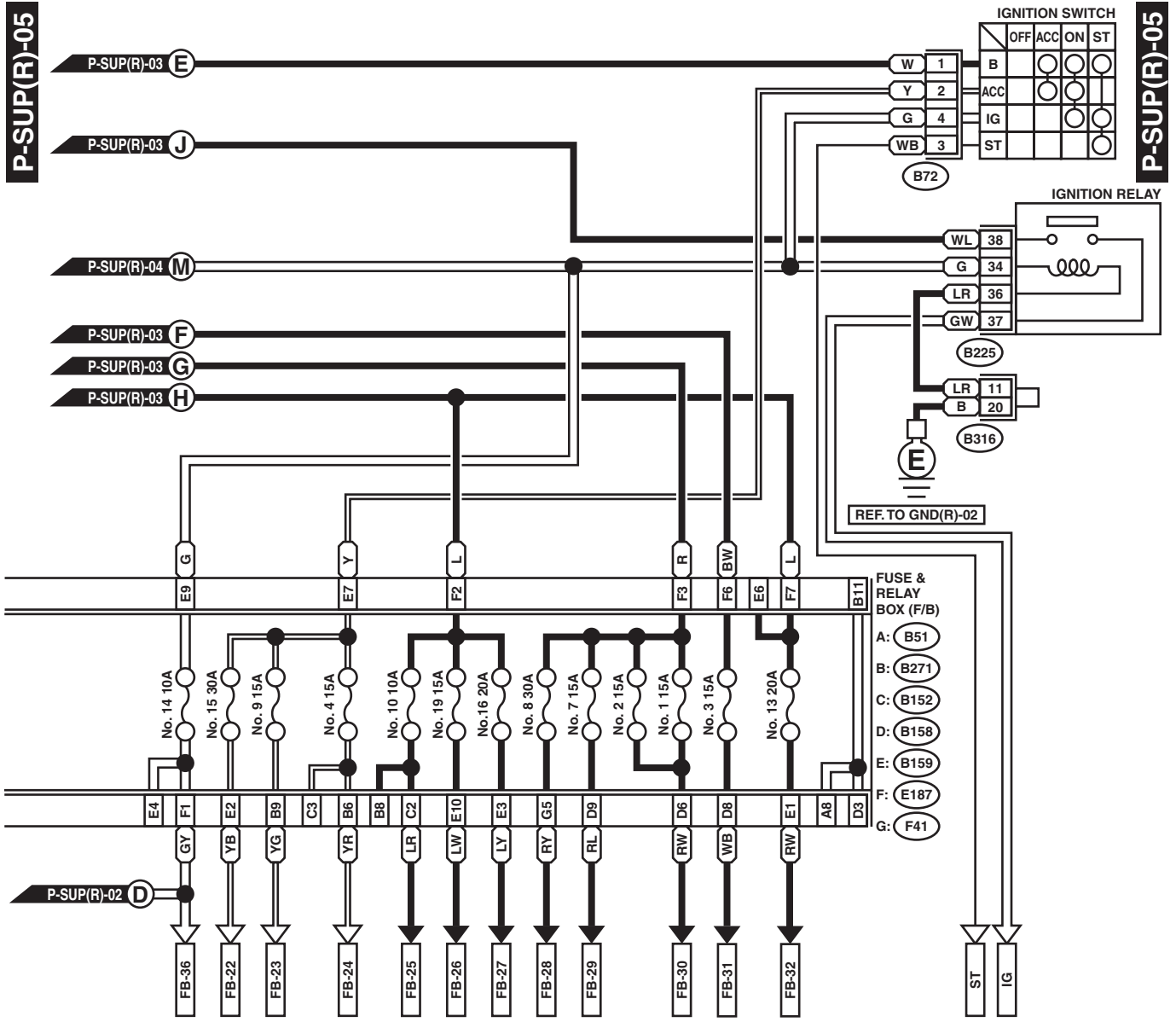

WI-03185

Power Supply Routing

WIRING SYSTEM

No.	Load
MB-1	Air conditioning relay holder
MB-2	Combination meter Headlight RH
MB-3	Headlight LH
MB-4	Horn
MB-5	Horn switch
MB-6	Hazard switch Keyless entry control module Key warning switch
MB-7	Transmission control module
MB-8	Diode (With rear fog light model) Lighting switch
MB-9	Data link connector Engine control module Fuel pump relay Immobilizer control module Main relay
MB-10	Combination meter Ignition switch illumination light Keyless entry control module Luggage room light Radio Room light Security relay Trailer connector Double lock control module Spot map light
MB-11	Headlight washer module Power window circuit breaker
SBF-7	ABS control module
ALT-1	Combination meter
ALT-2	Engine control module
IG	Hazard switch Check connector Headlight washer switch Ignition relay OP connector Power window relay Vehicle speed sensor (MT model)
ST	Engine control module Cruise control module Ignition switch Inhibitor switch (AT model) Security relay Starter motor (MT model)
FB-1	Hazard switch Combination meter Keyless entry control module Rear turn signal light LH Trailer connector Lighting switch Turn signal switch

No.	Load
FB-2	Hazard switch Combination meter Front turn signal light LH Rear turn signal light LH Rear turn signal light RH Side turn signal light LH Trailer connector Keyless entry control module Lighting switch Turn signal switch
FB-3	Parking switch
FB-4	Front turn signal light RH Side turn signal light RH
FB-5	Front turn signal light LH
FB-6	Front clearance light LH Front clearance light RH Headlight leveler LH Headlight leveler RH
FB-7	License plate light Tail light LH Tail light RH Trailer connector
FB-9	Radio Combination meter Front accessory power supply socket Hazard switch OP connector Wiper deicer switch Front fog light switch
FB-10	Parking switch
FB-11	Lighting switch
FB-13	Rear defogger
FB-14	Double lock control module Rear defogger timer
FB-15	Cruise control main switch Cruise control module Inhibitor switch (AT model) Wiper deicer relay Wiper deicer switch
FB-16	ABS control module Main fan relay
FB-17	Air conditioning relay Pressure switch Sub fan relay
FB-18	AUTO A/C control module Blower motor relay Rear defogger switch Rear defogger timer Double lock control module FRESH/RECIRE actuator Heater cock solenoid (2.0 L Non-turbo model)
FB-19	Engine control module Fuel pump relay Immobilizer control module Security control module Transmission control module
FB-20	Airbag control module
FB-21	Airbag control module

Power Supply Routing

WIRING SYSTEM

No.	Load
FB-22	Front washer motor Front wiper motor Front wiper switch
FB-23	Clock Radio
FB-24	Front accessory power supply socket Remote controlled rearview mirror switch Seat heater relay
FB-25	Rear fog light relay
FB-26	Rear accessory power supply socket
FB-27	Stop light switch
FB-28	ABS control module
FB-29	Front fog light relay
FB-30	Blower motor relay
FB-31	Double lock control module Keyless entry control module
FB-32	Wiper deicer relay
FB-33	Cruise control main switch Front fog light switch Front fog light relay Glove box illumination light (Turbo model) Headlight leveler switch Illumination control module Lighting switch Rear fog light relay
FB-34	At power mode & Hold mode switch Select lever illumination light
FB-35	Parking switch
FB-36	Combination meter

4. Ground Distribution

A: WIRING DIAGRAM

1. CHASSIS GROUND LHD MODEL

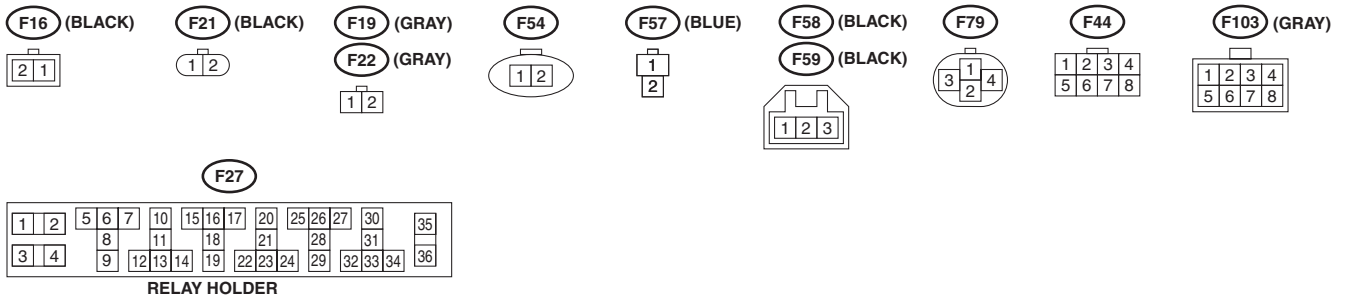
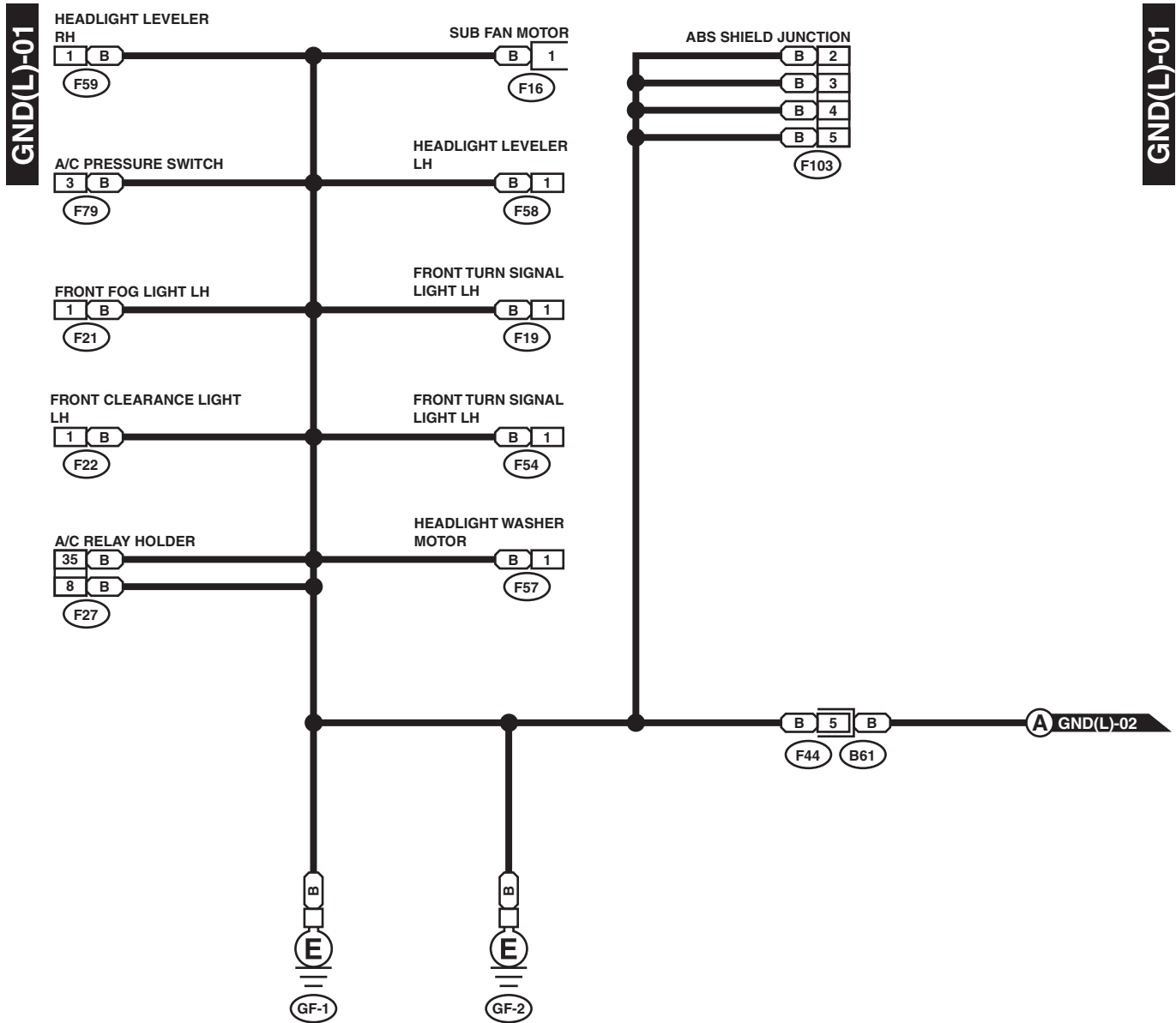

Ground Distribution

WIRING SYSTEM

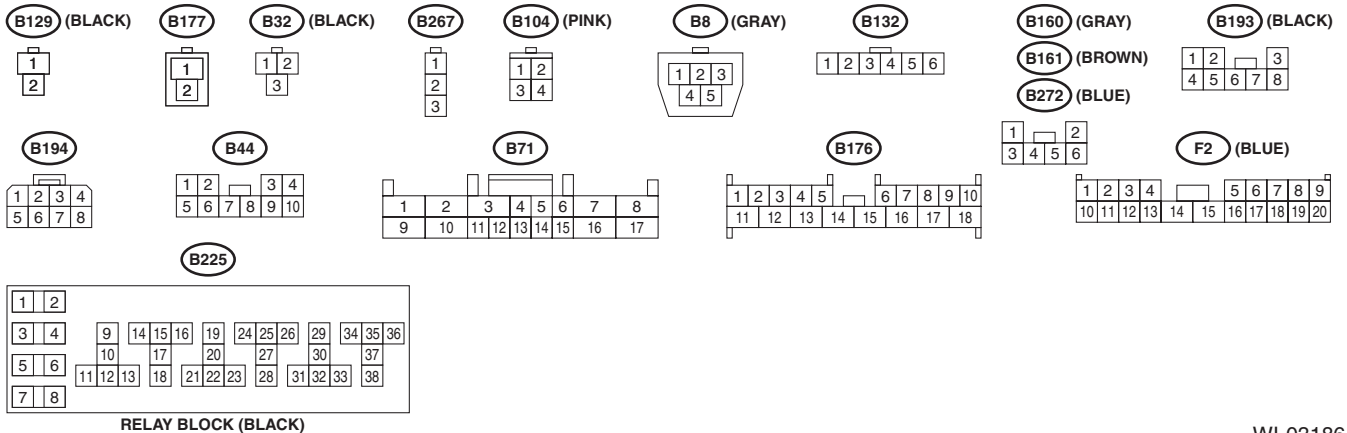
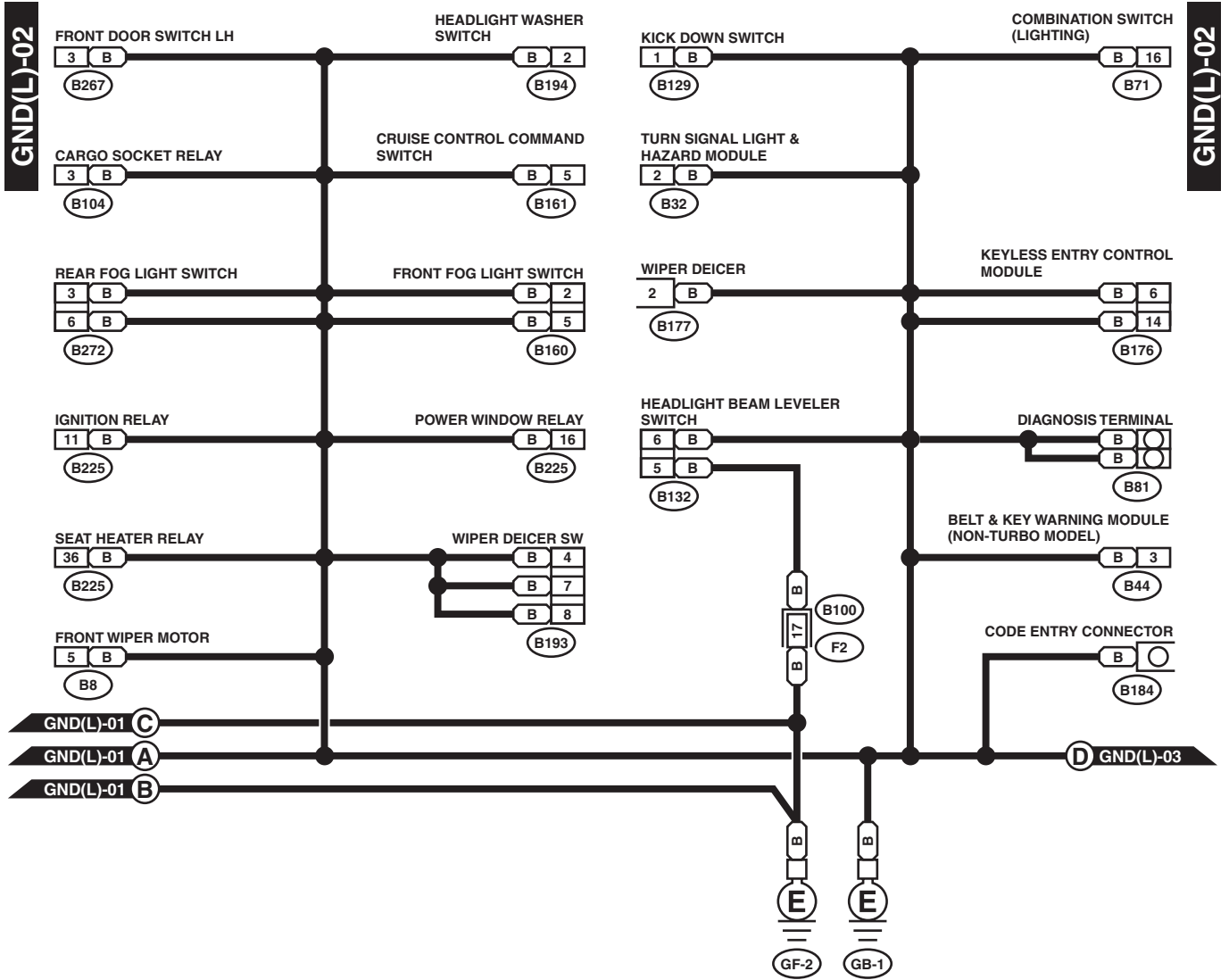

WI-03186

Ground Distribution

WIRING SYSTEM

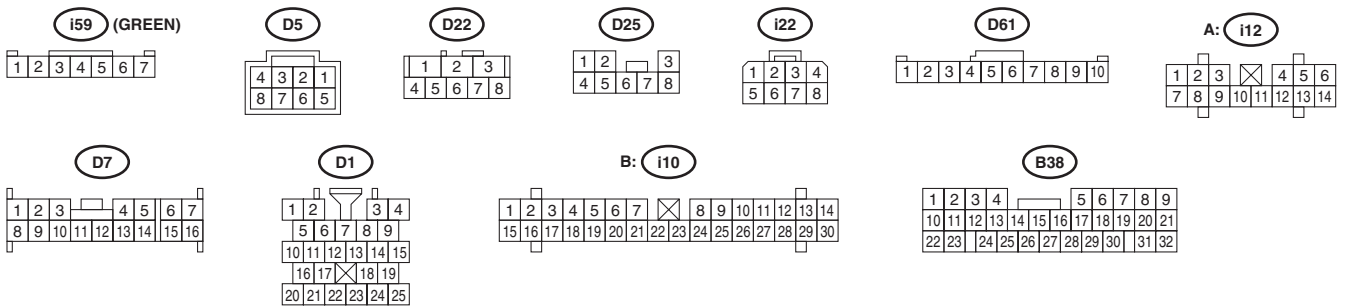
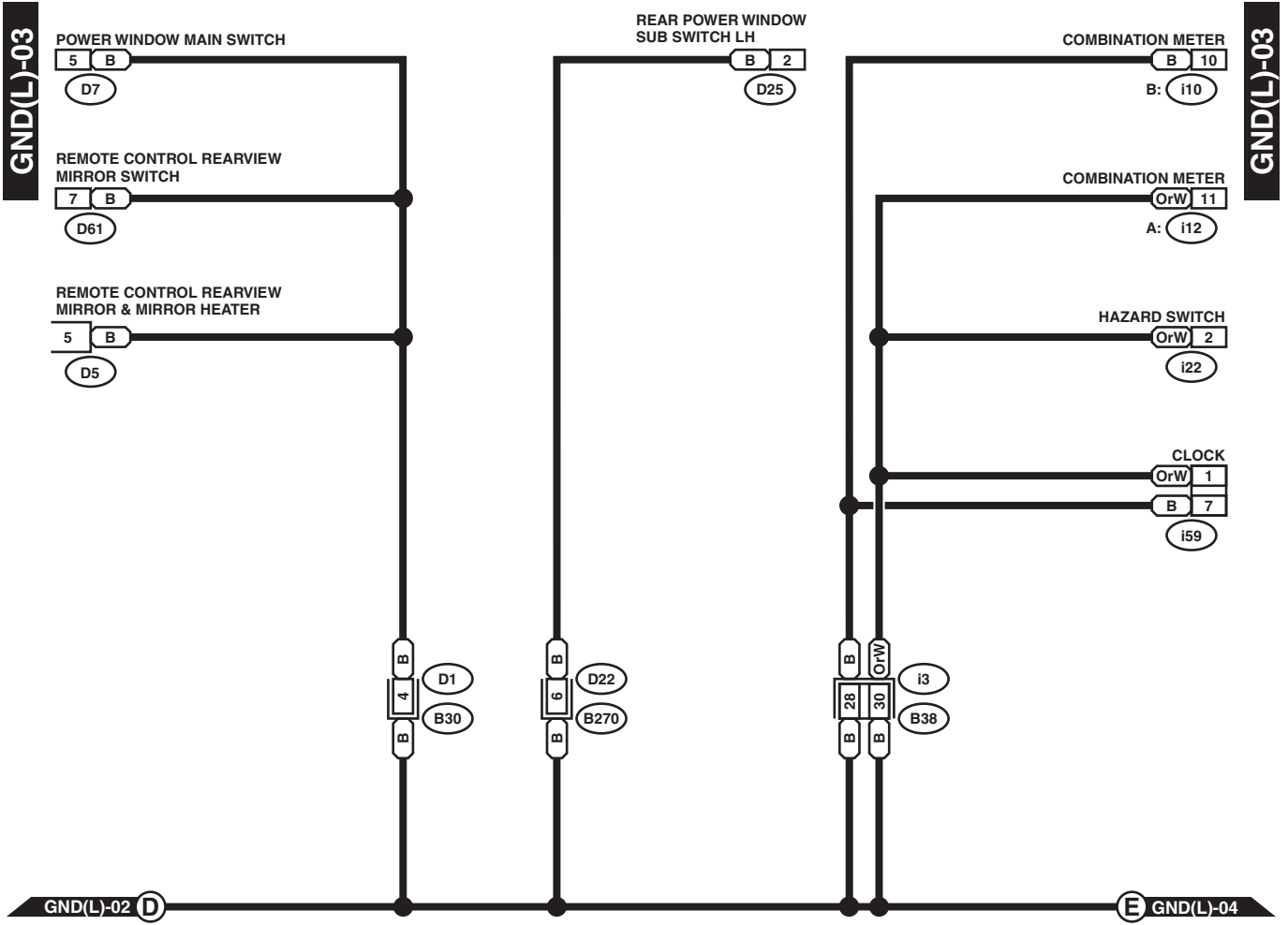

WI-03187

Ground Distribution

WIRING SYSTEM

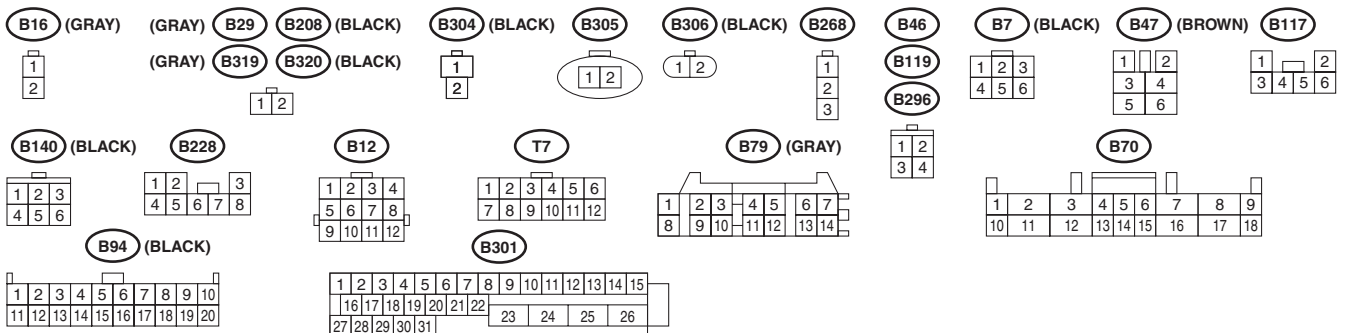
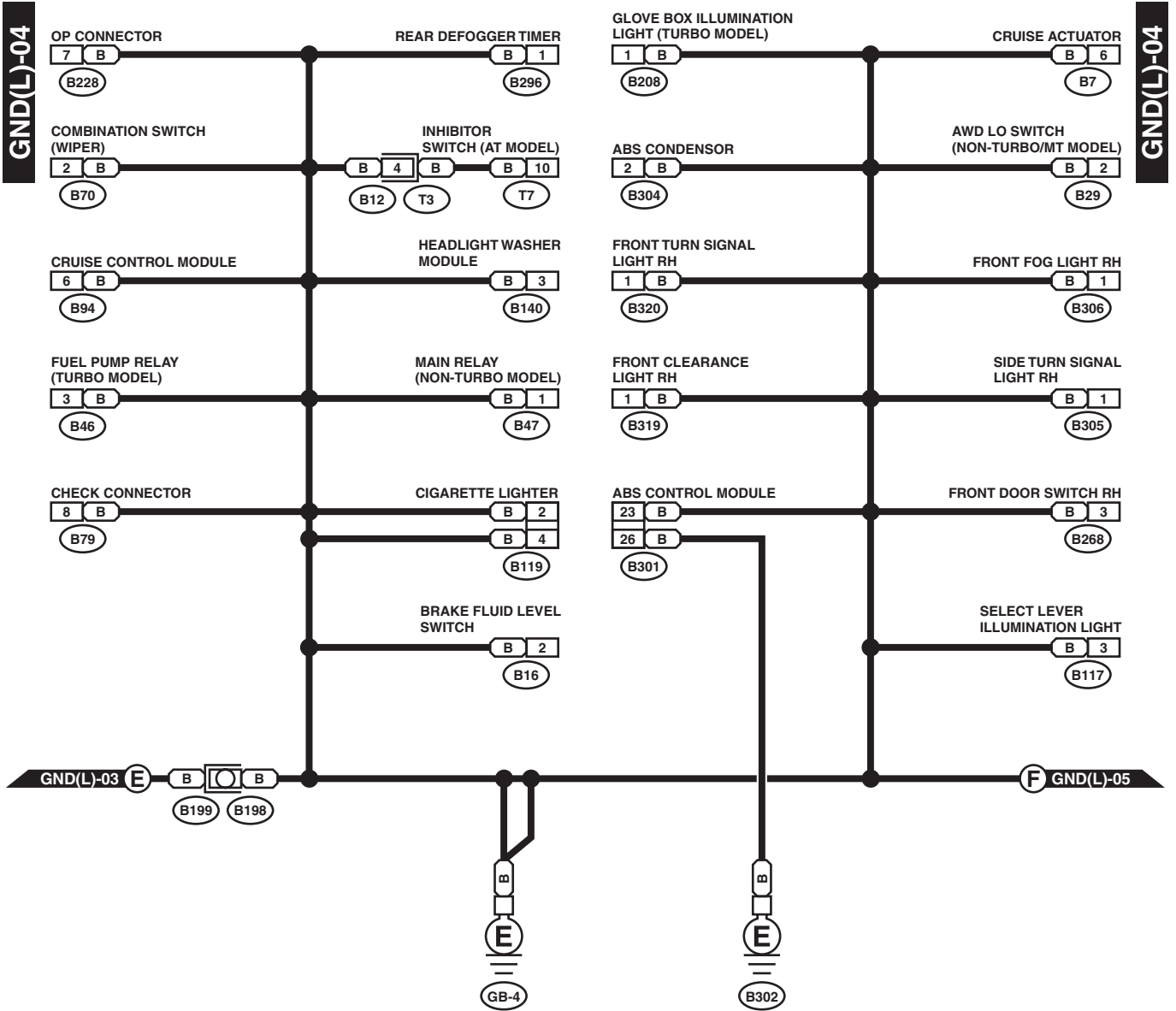

WI-03188

Ground Distribution

WIRING SYSTEM

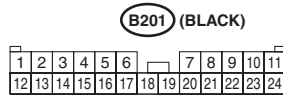
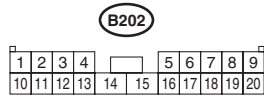
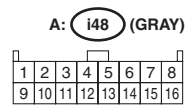
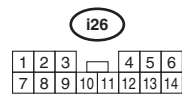
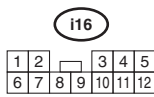
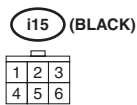
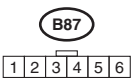
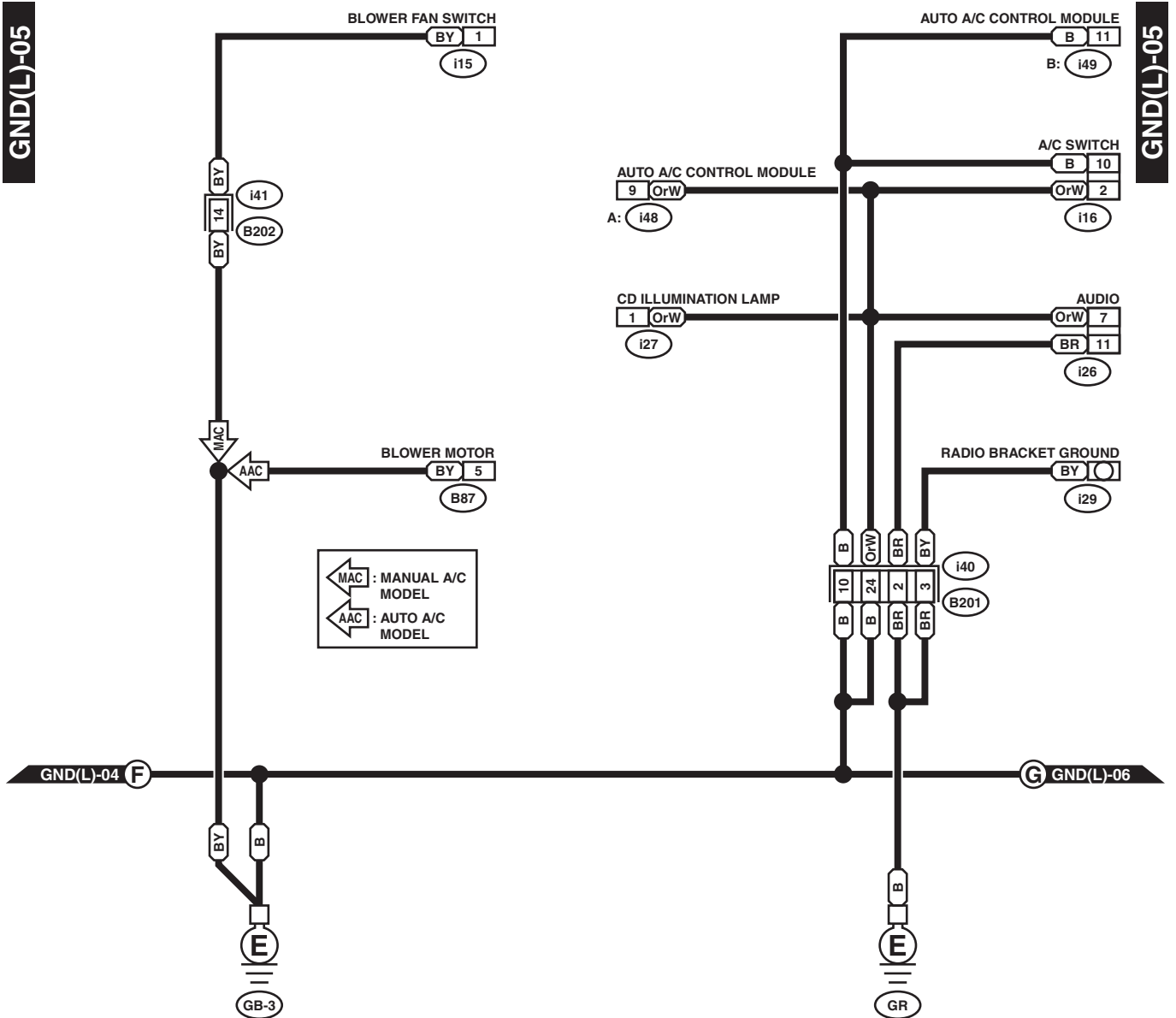

WI-03189

Ground Distribution

WIRING SYSTEM

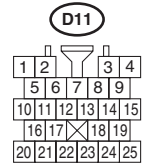
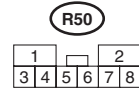
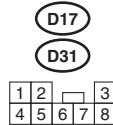
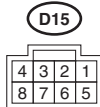
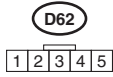
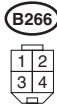
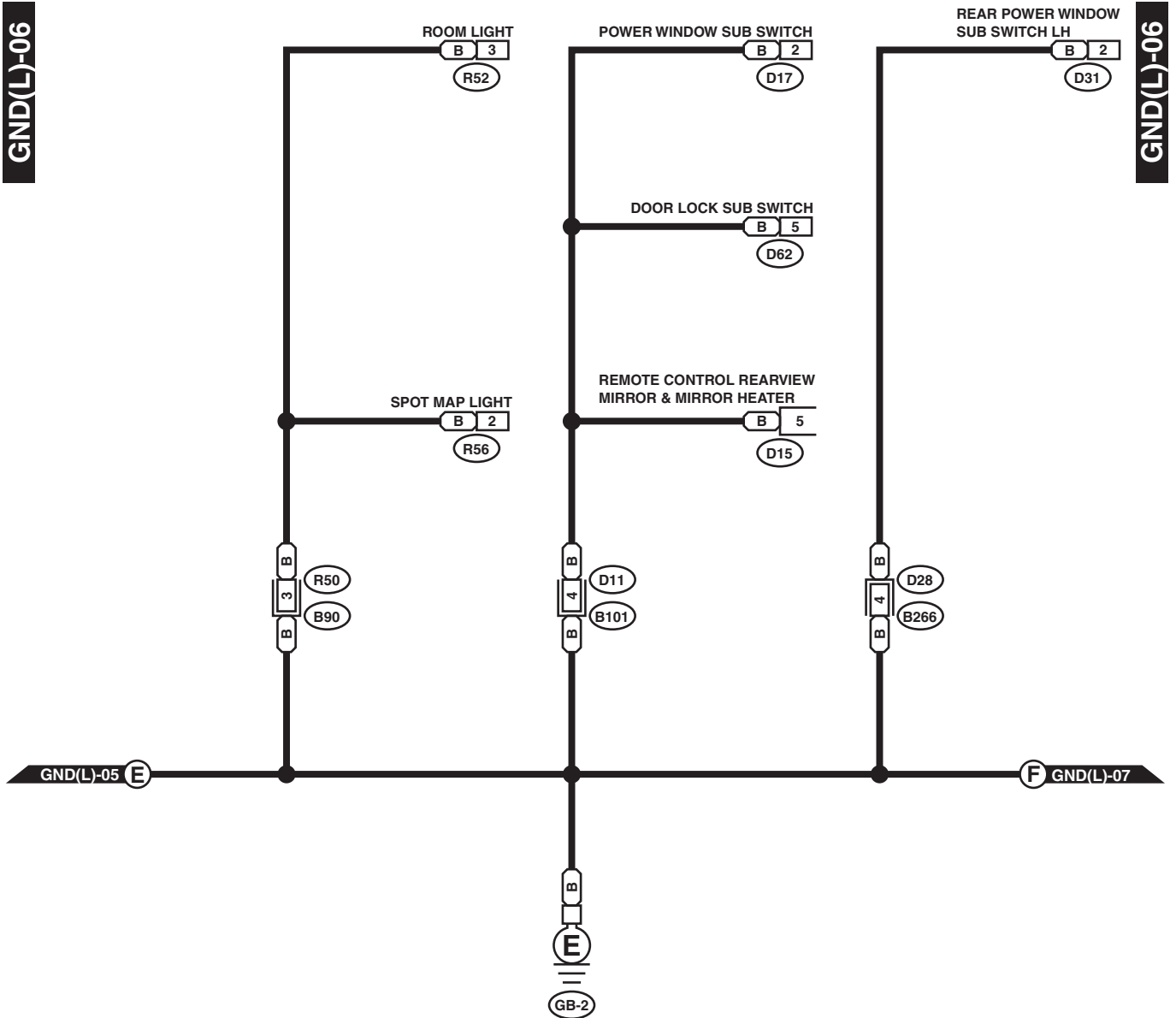

WI-00239

Ground Distribution

WIRING SYSTEM

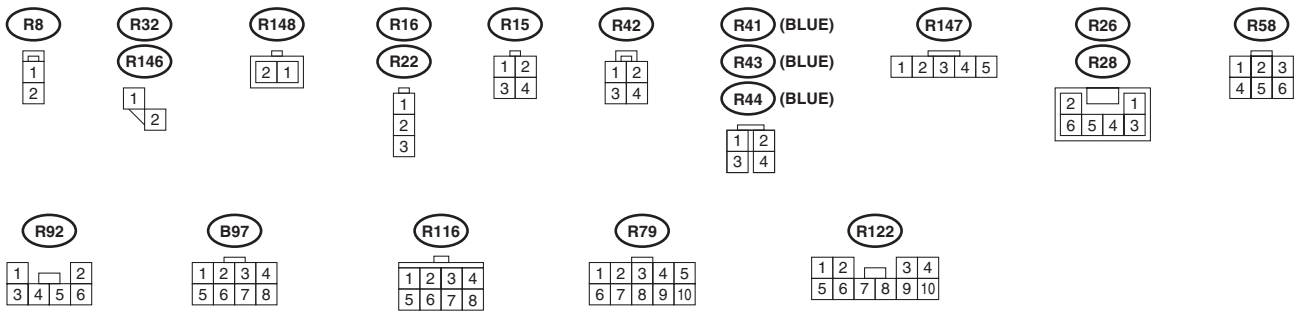
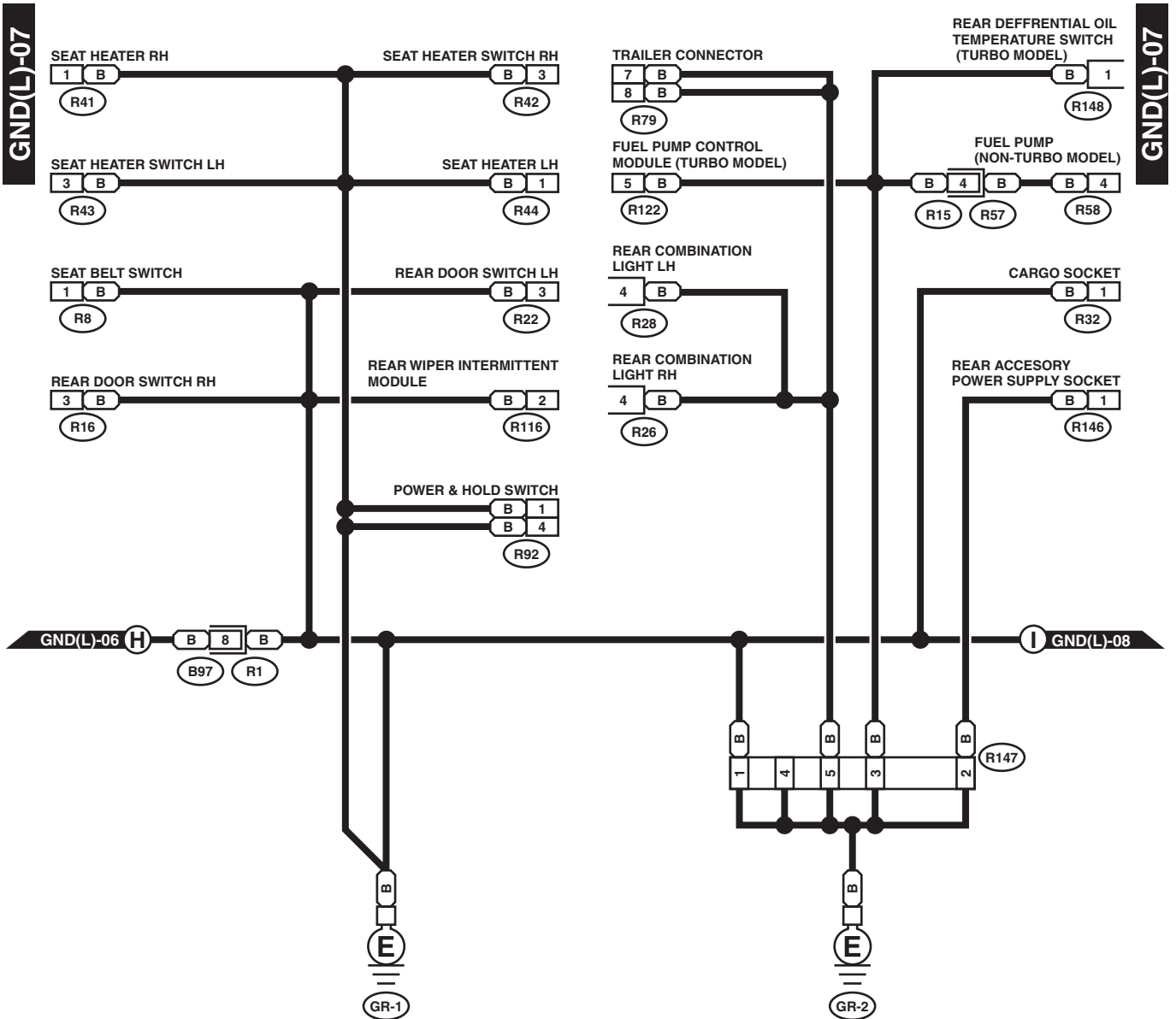

WI-03190

Ground Distribution

WIRING SYSTEM

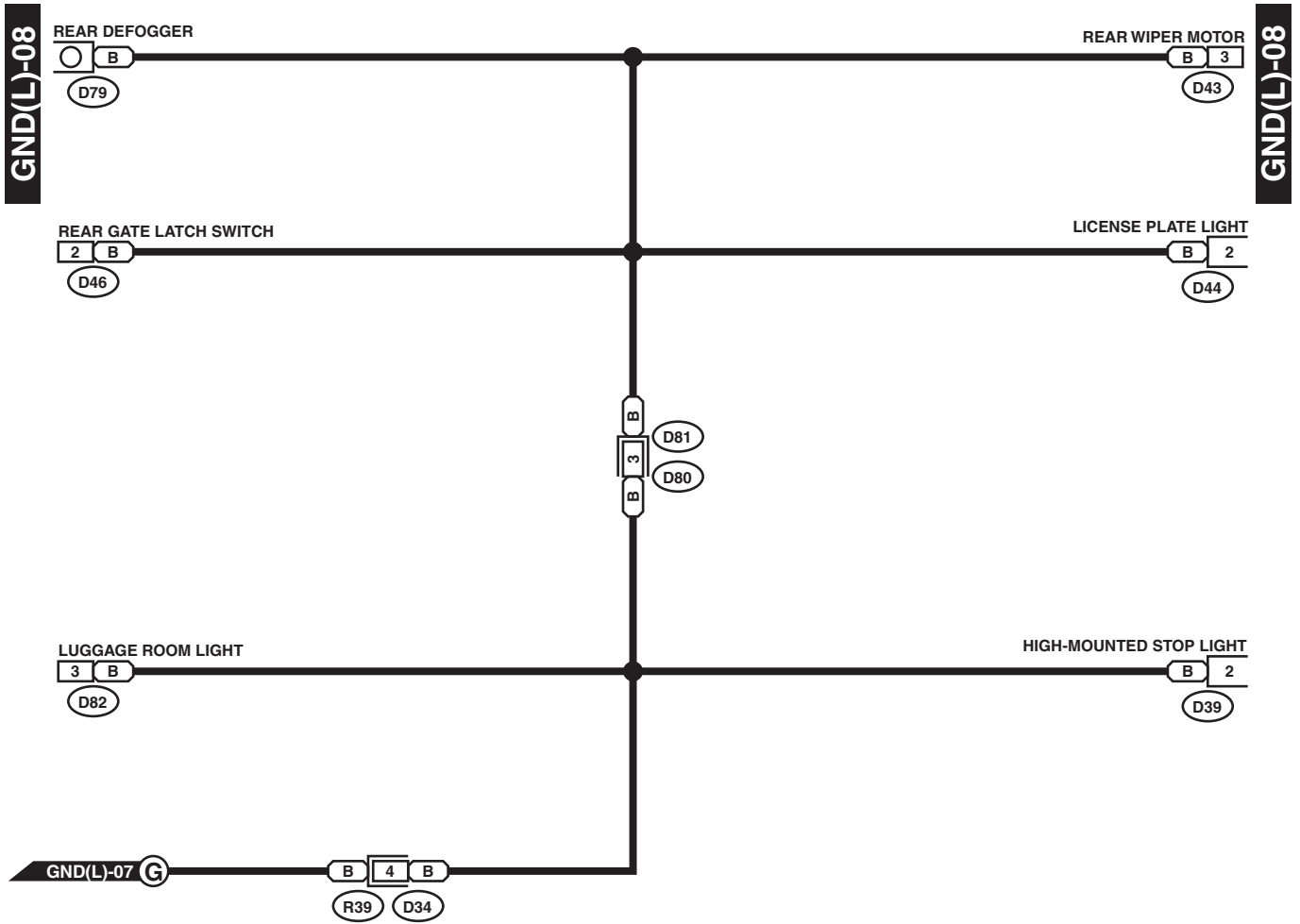

WI-00241

2. ENGINE GROUND LHD TURBO MODEL

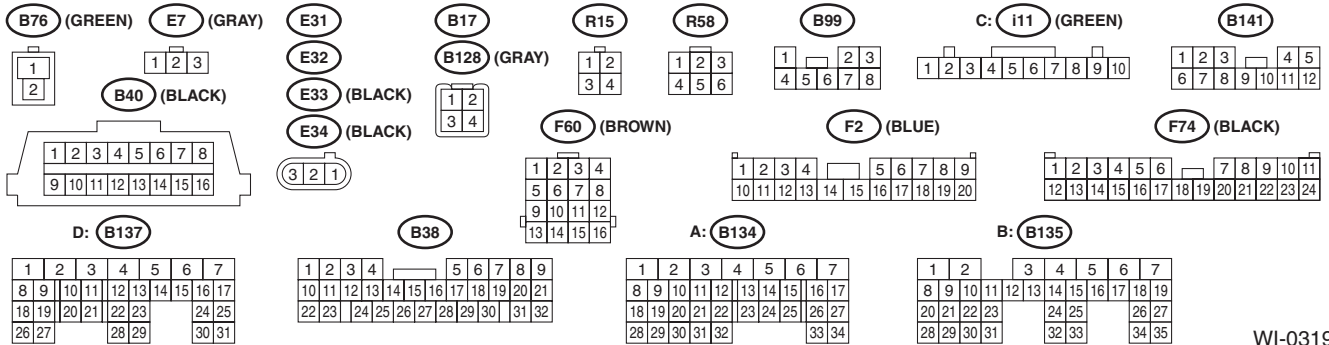
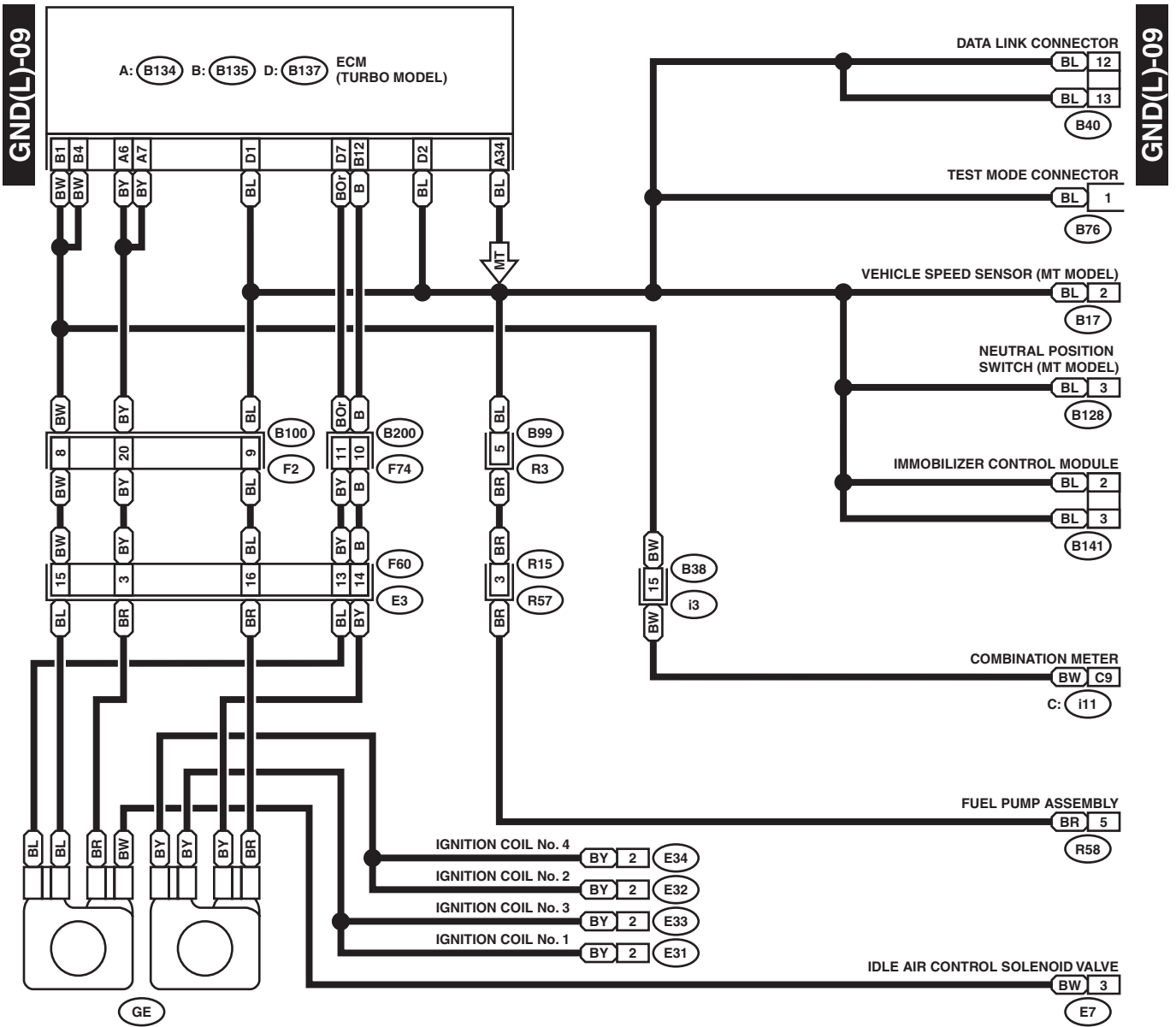

WI-03191

Ground Distribution

WIRING SYSTEM

3. ENGINE GROUND LHD NON-TURBO MODEL

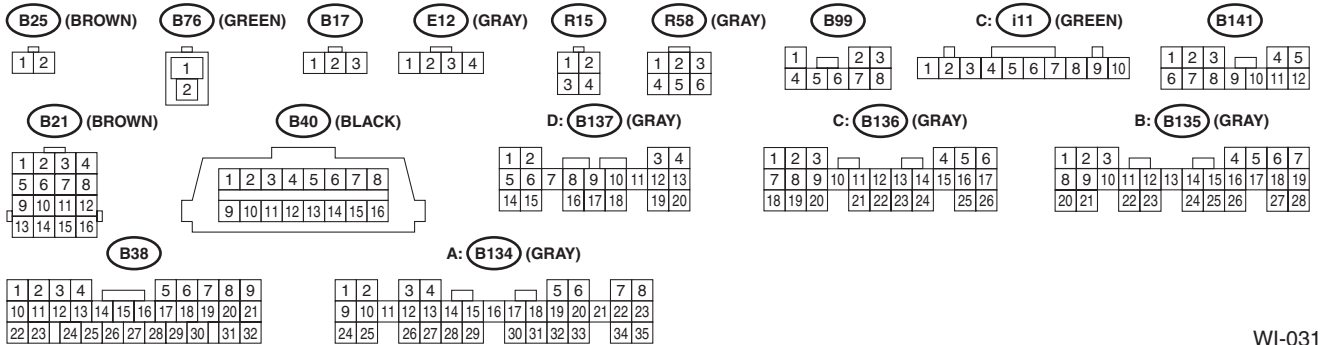
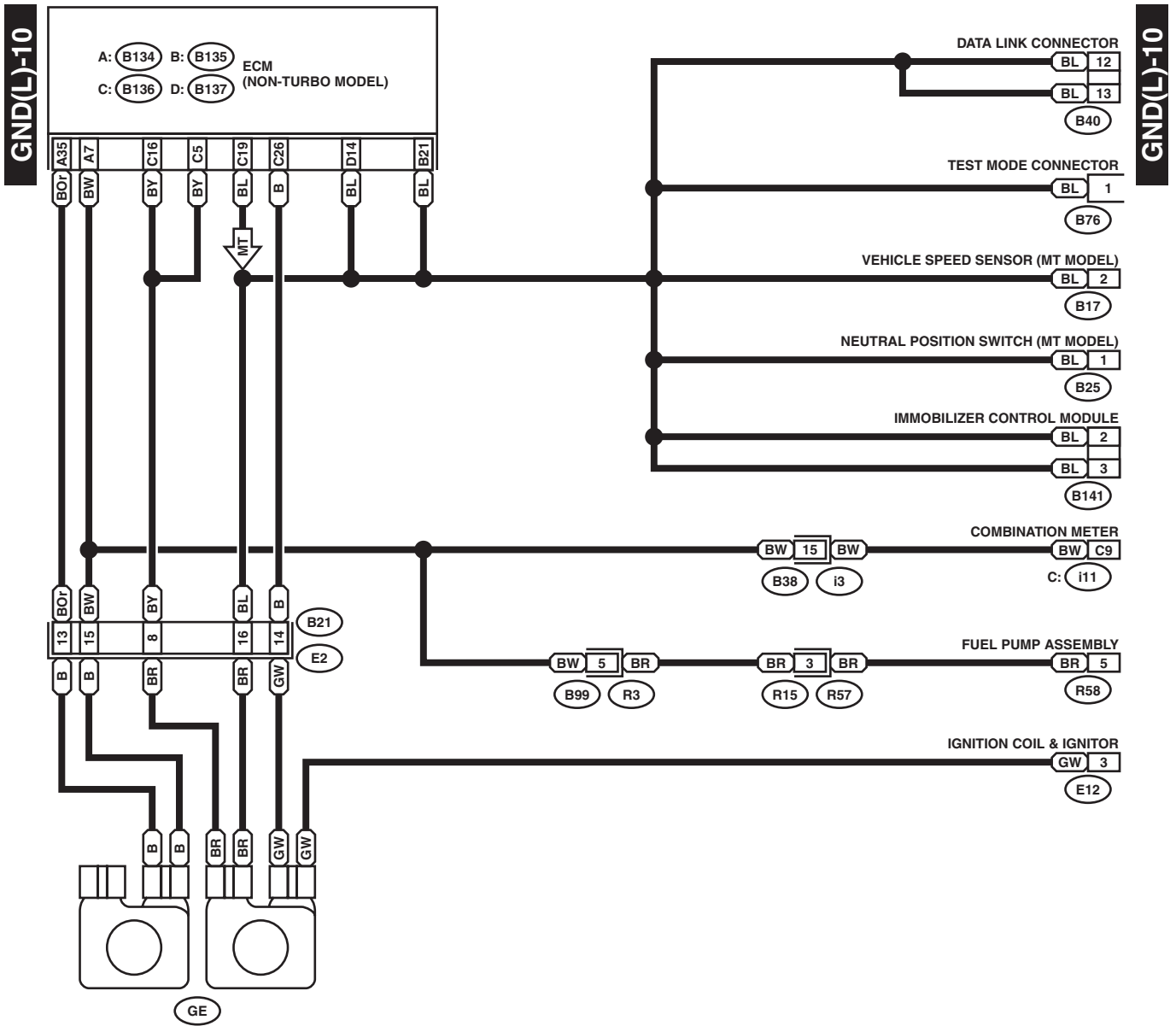

WI-03192

4. TRANSMISSION GROUND LHD TURBO MODEL

GND(L)-11

GND(L)-11

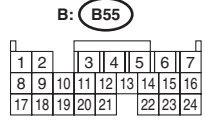
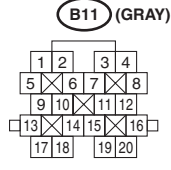
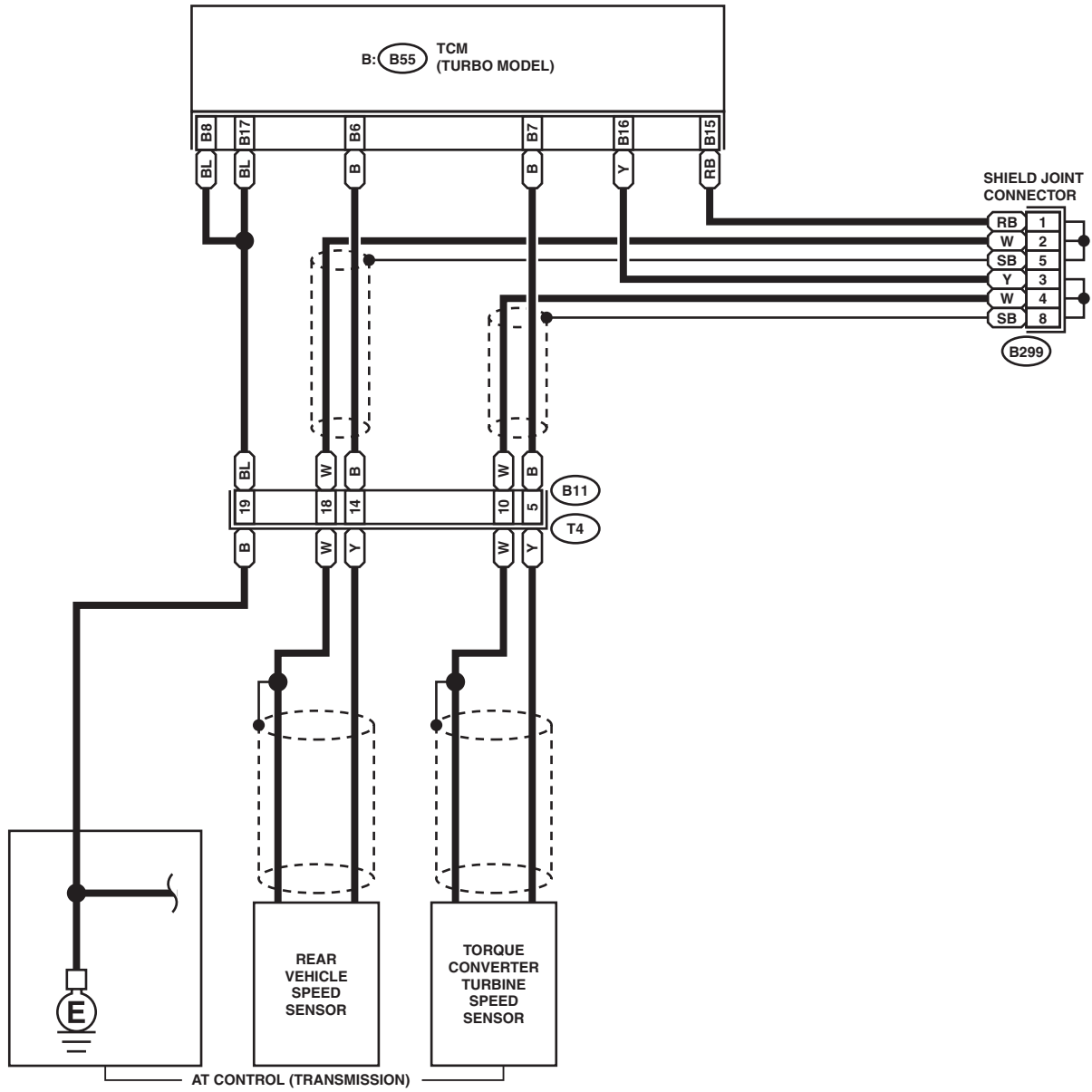

Ground Distribution

WIRING SYSTEM

5. TRANSMISSION GROUND LHD NON-TURBO MODEL

GND(L)-12

GND(L)-12

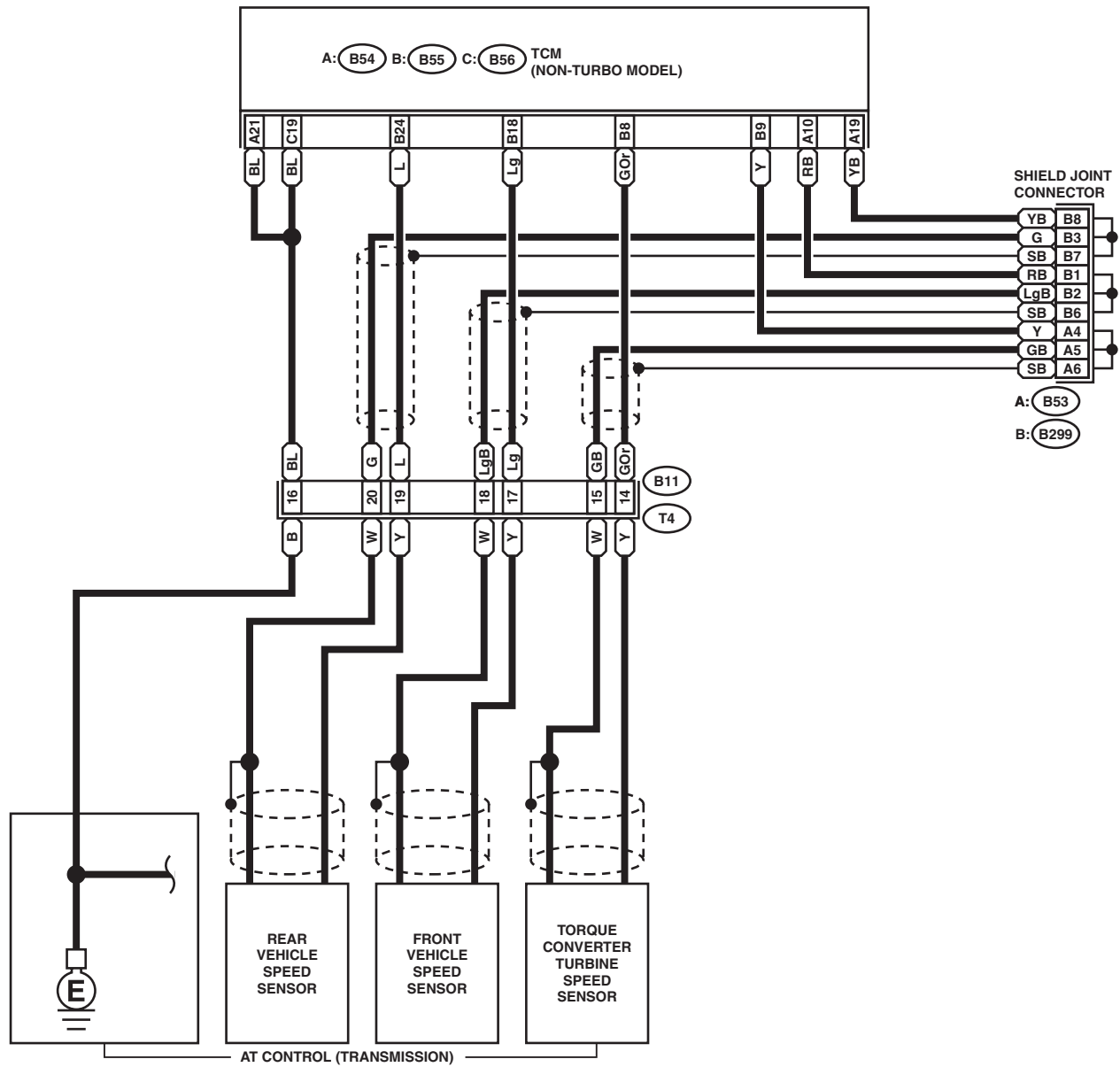

A: B53

B: B299

B11 (BLACK)

A: B54

B: B55 (GRAY)

C: B56 (GREEN)

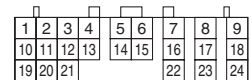
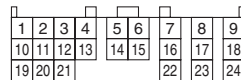
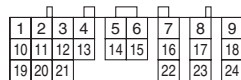
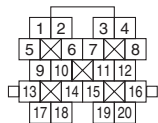
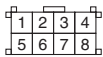

Ground Distribution

WIRING SYSTEM

6. CHASSIS GROUND RHD MODEL

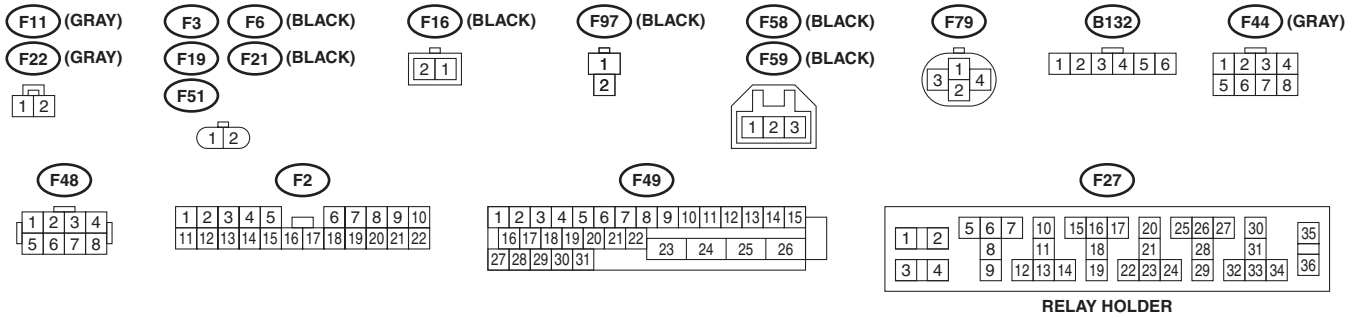
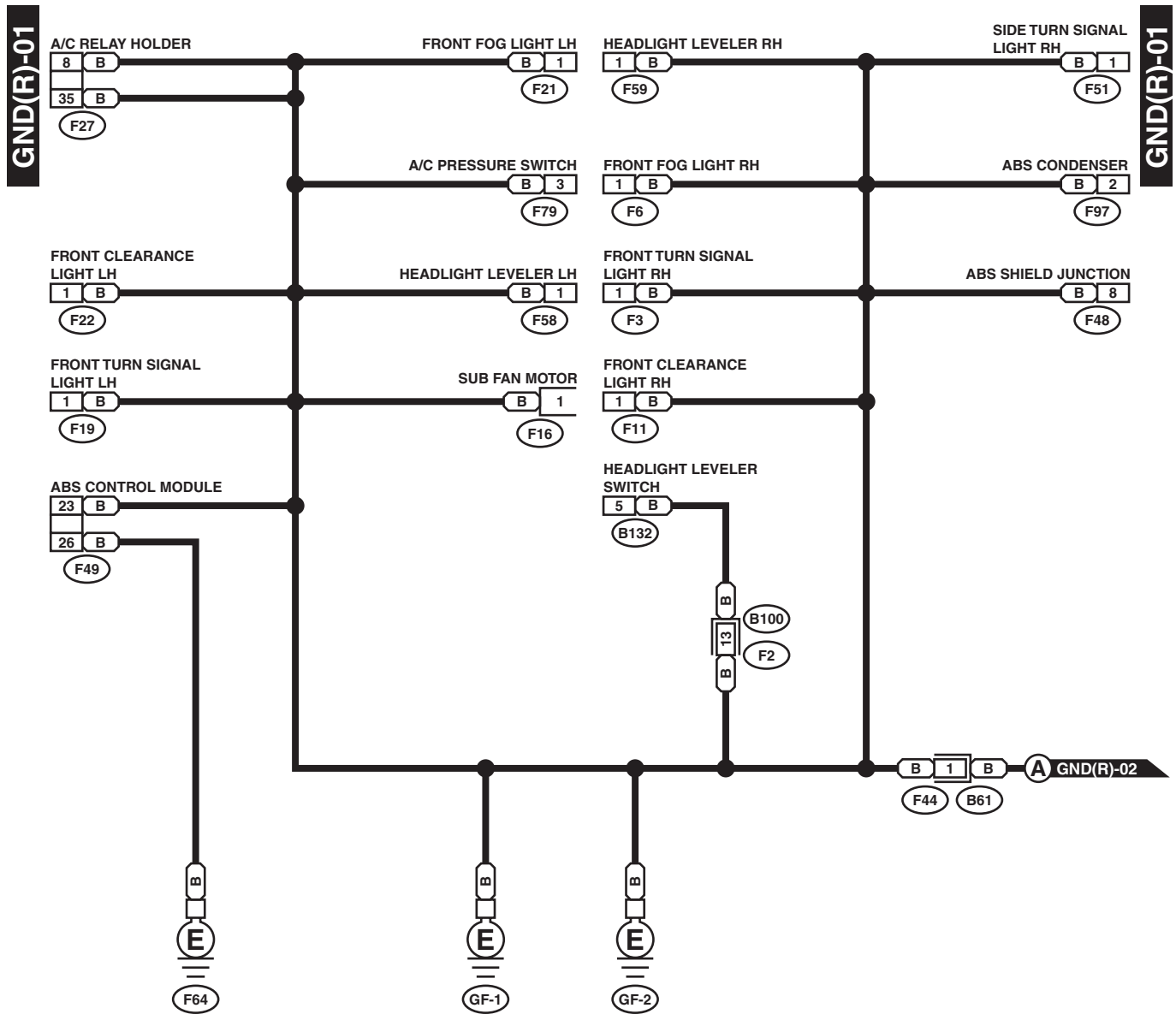

WI-00246

Ground Distribution

WIRING SYSTEM

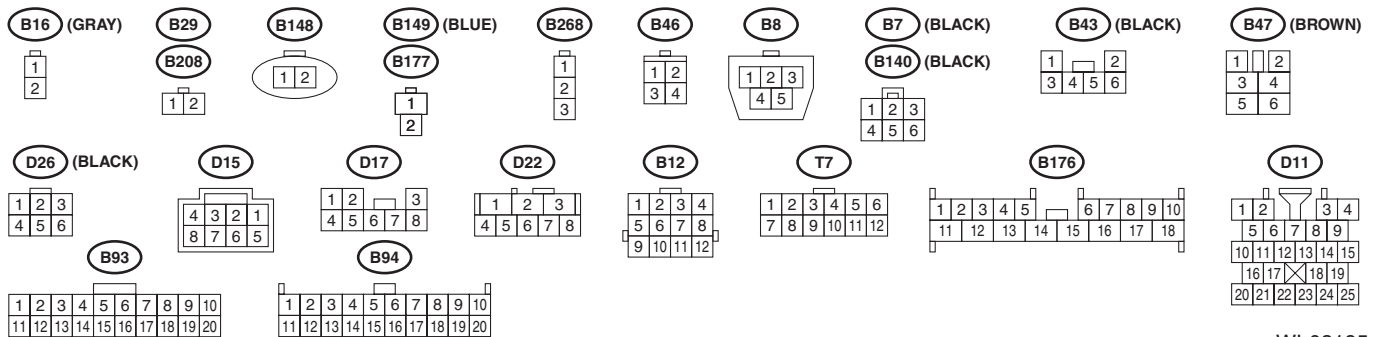
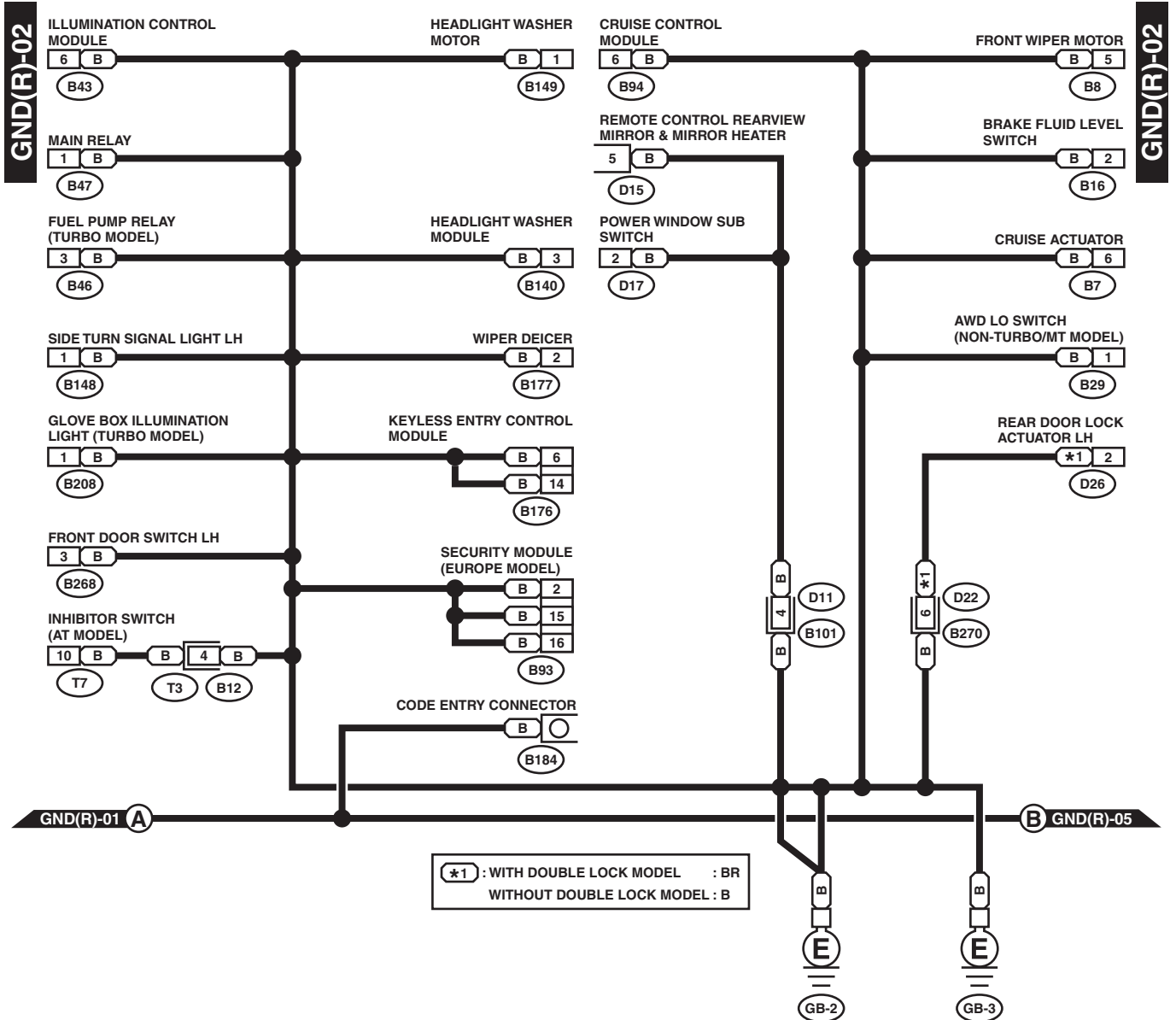

WI-03195

Ground Distribution

WIRING SYSTEM

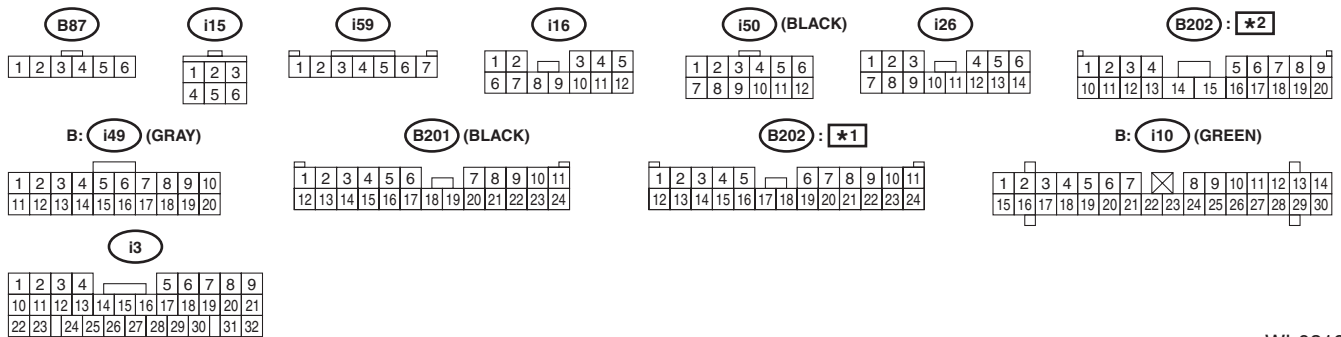
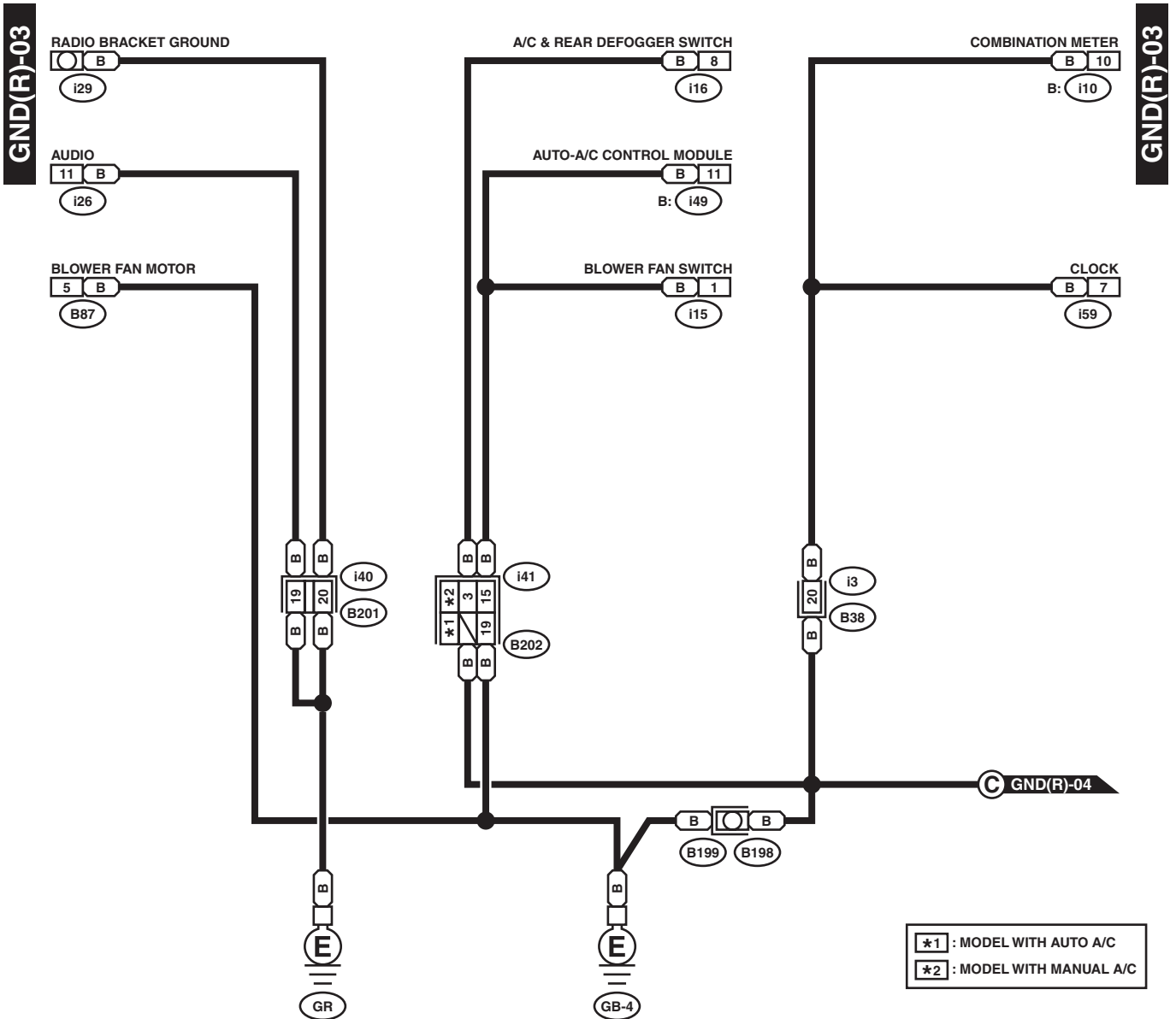

WI-03196

Ground Distribution

WIRING SYSTEM

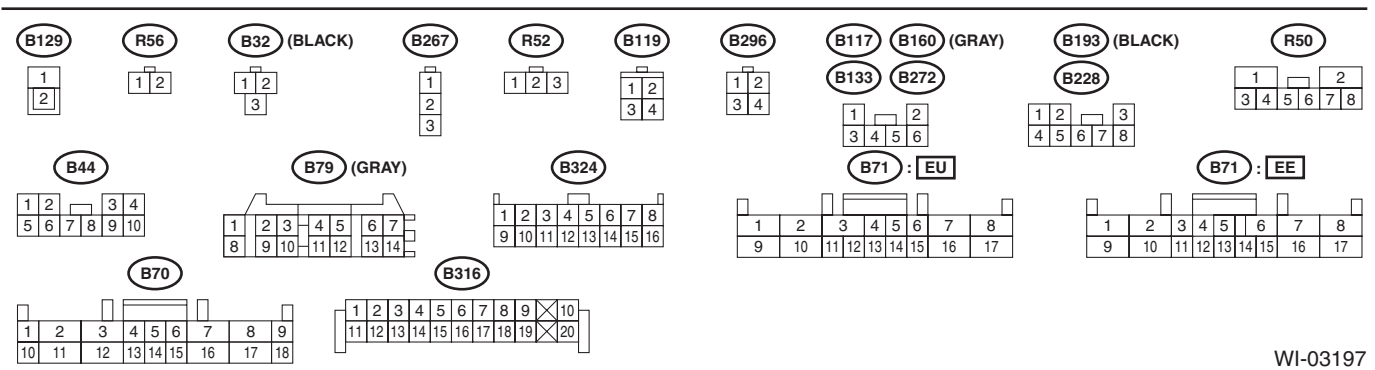
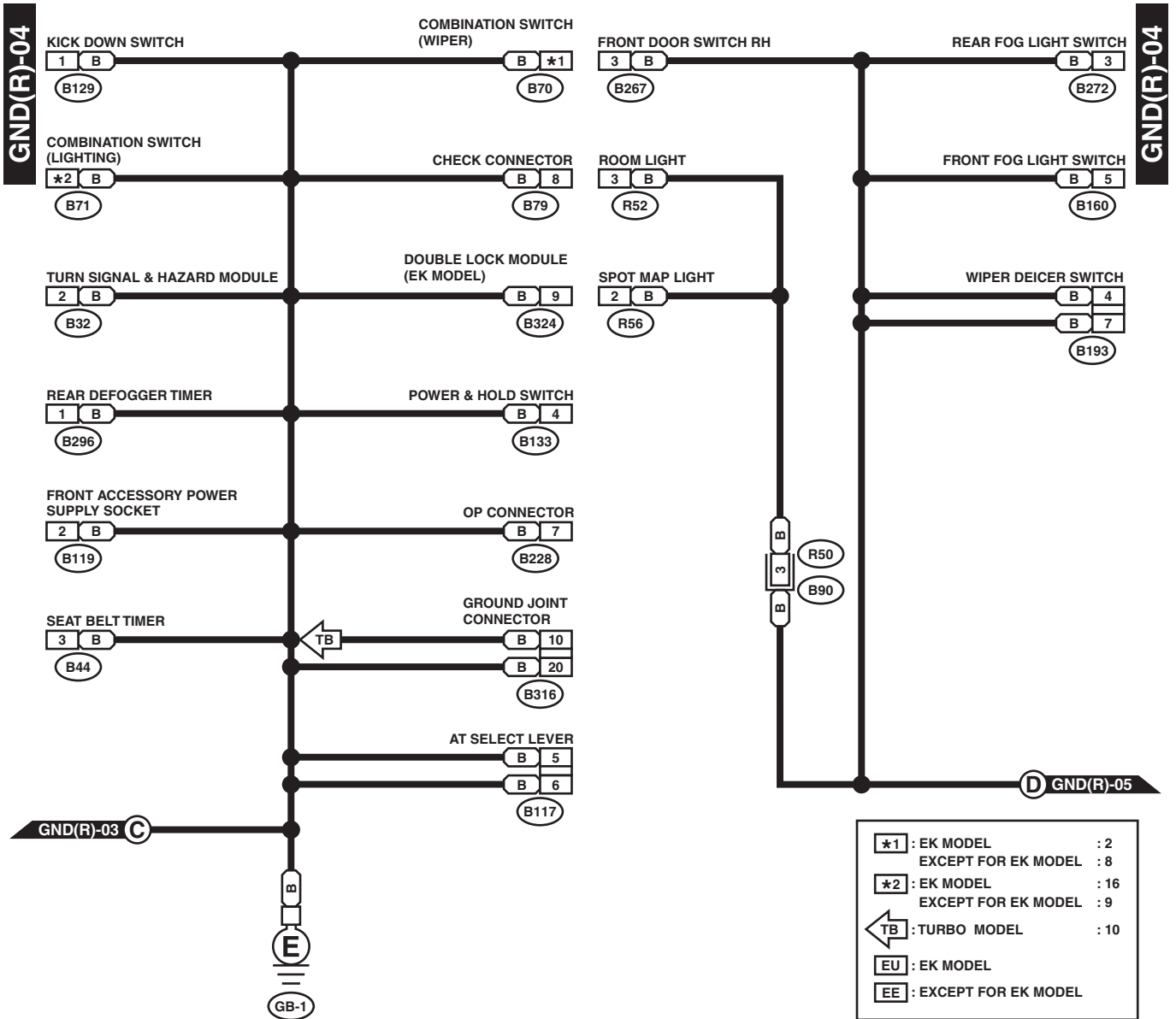

WI-03197

Ground Distribution

WIRING SYSTEM

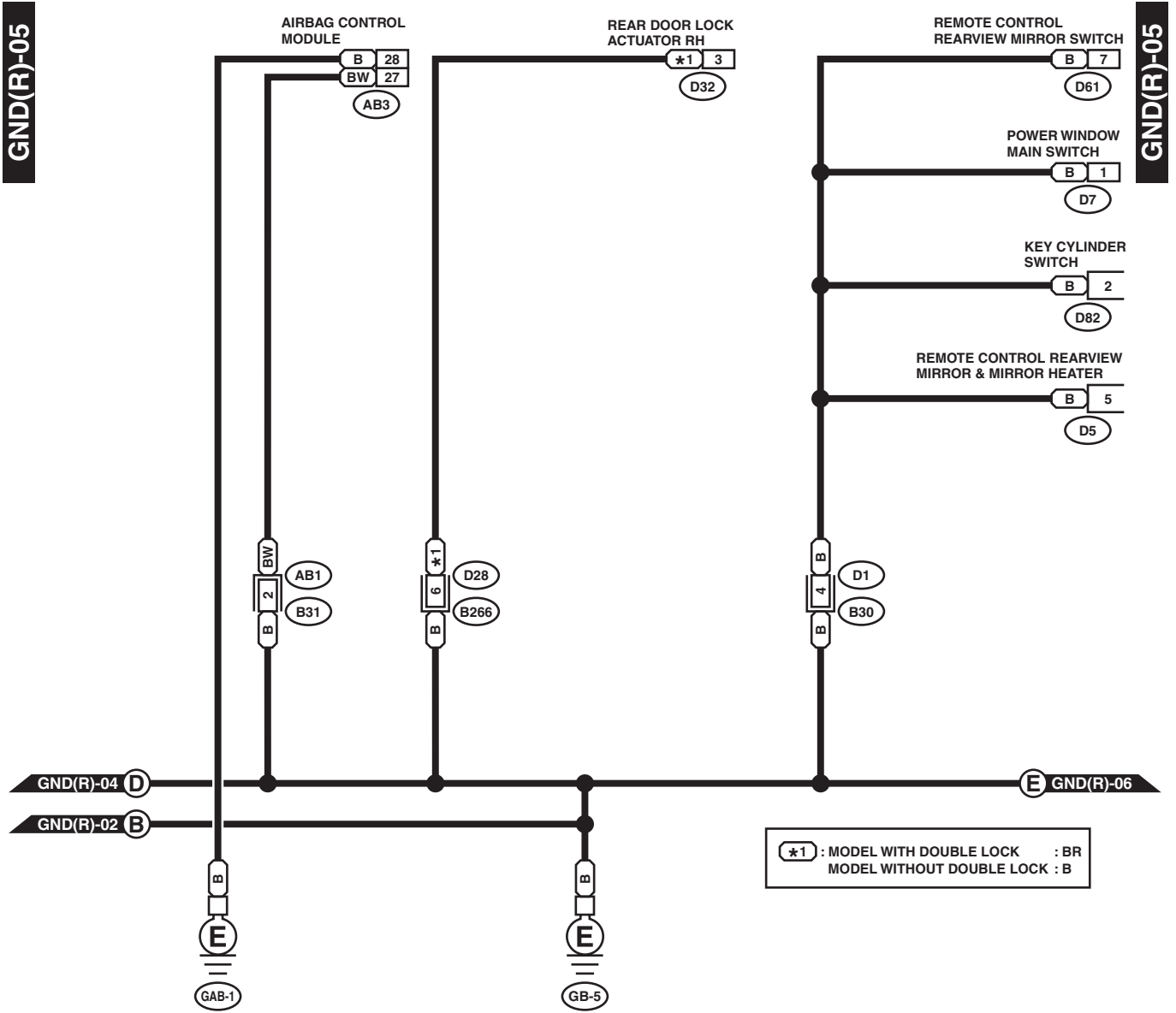

D82 (BROWN)



B31



D32 (BLACK)



D5

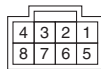

D28

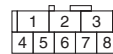

D61

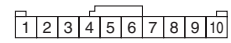

D7

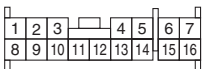

D1

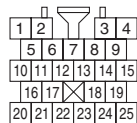

AB3

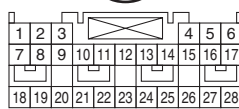

WI-03198

Ground Distribution

WIRING SYSTEM

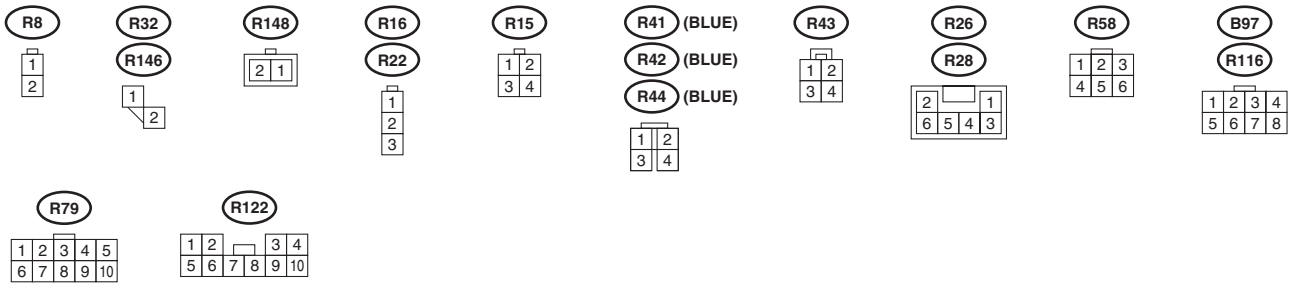
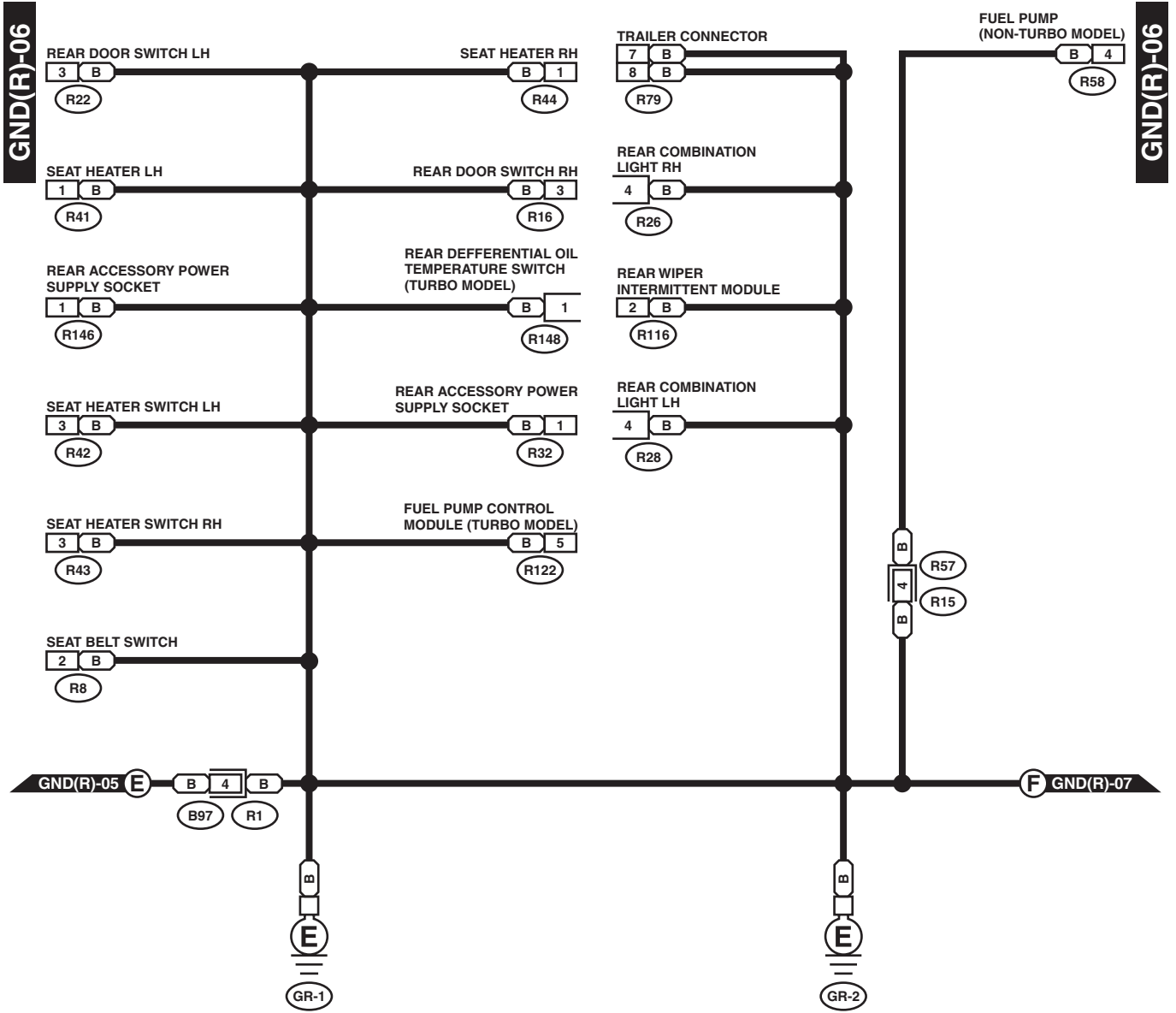

WI-03199

Ground Distribution

WIRING SYSTEM

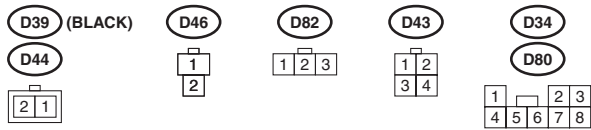
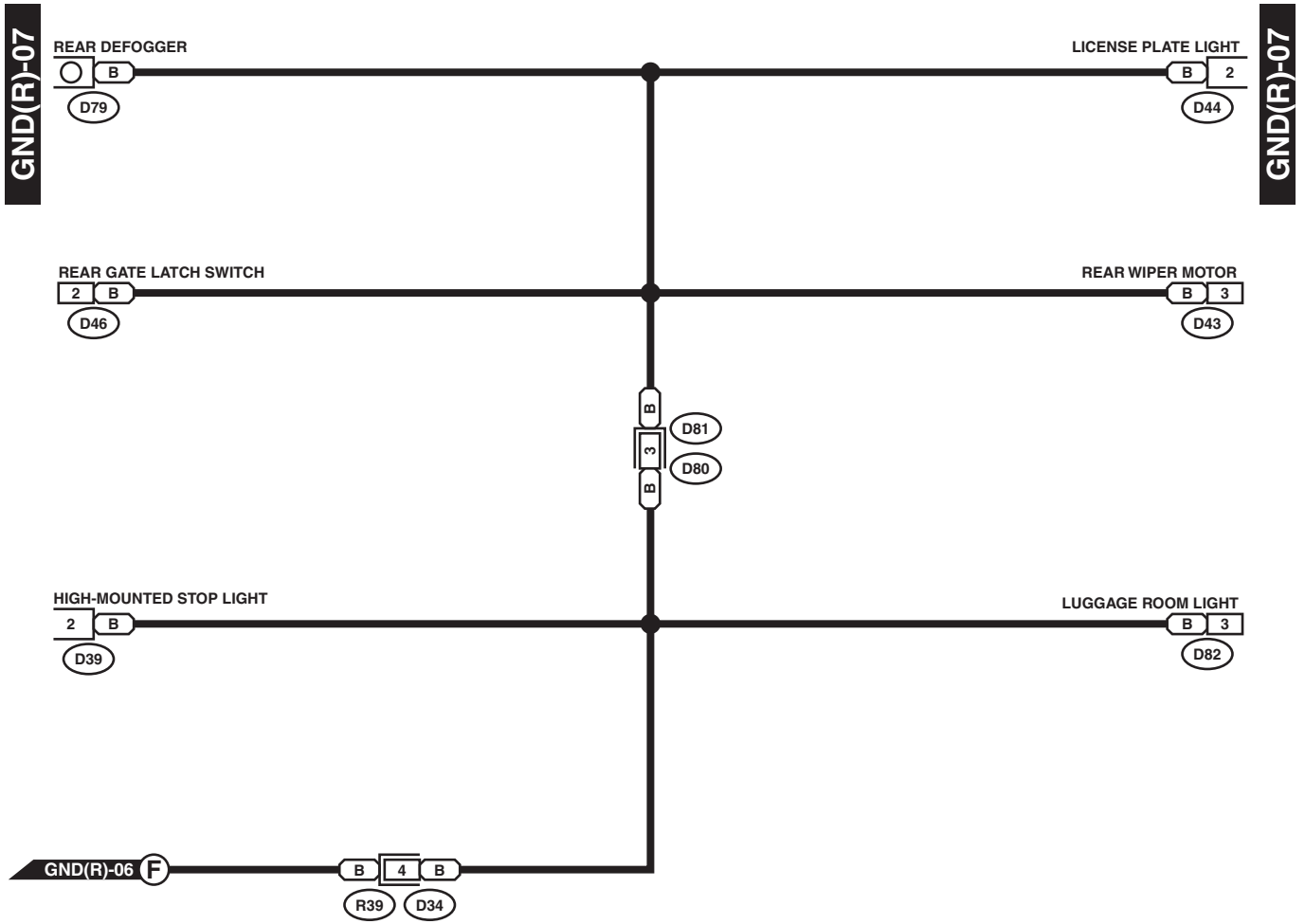

WI-00252

Ground Distribution

WIRING SYSTEM

7. ENGINE GROUND RHD TURBO MODEL

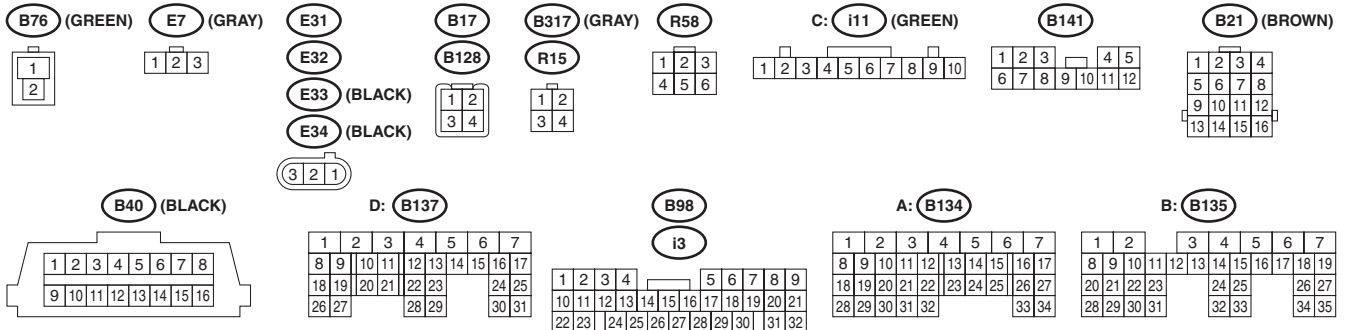
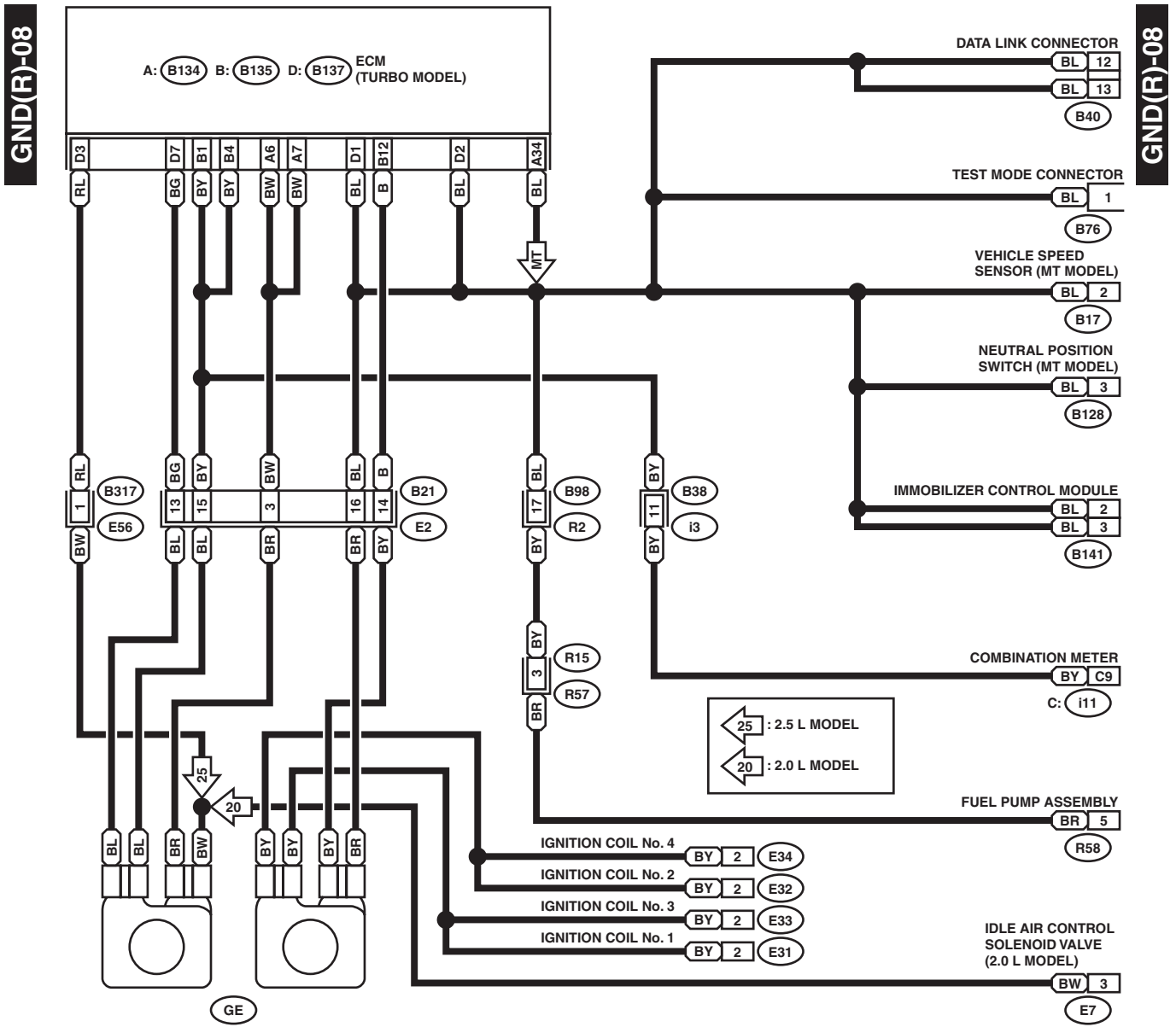

WI-03200

8. ENGINE GROUND RHD NON-TURBO MODEL

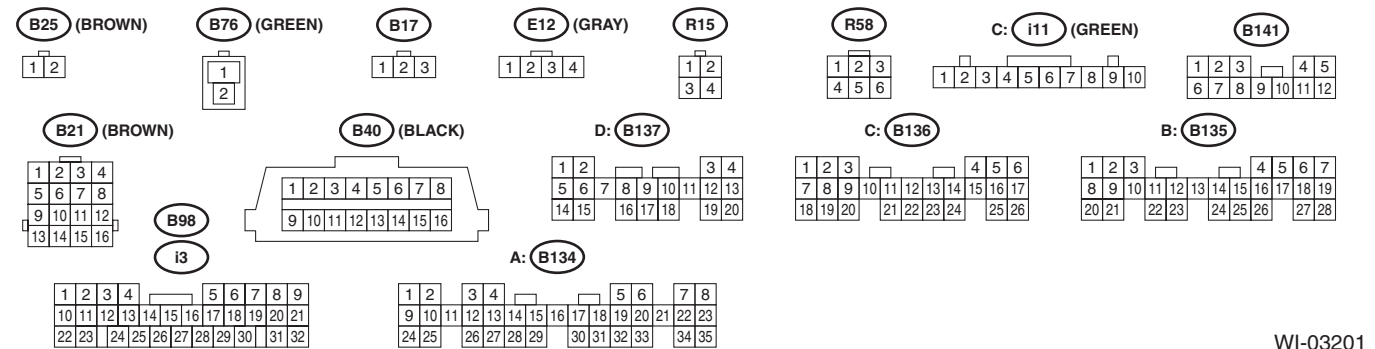
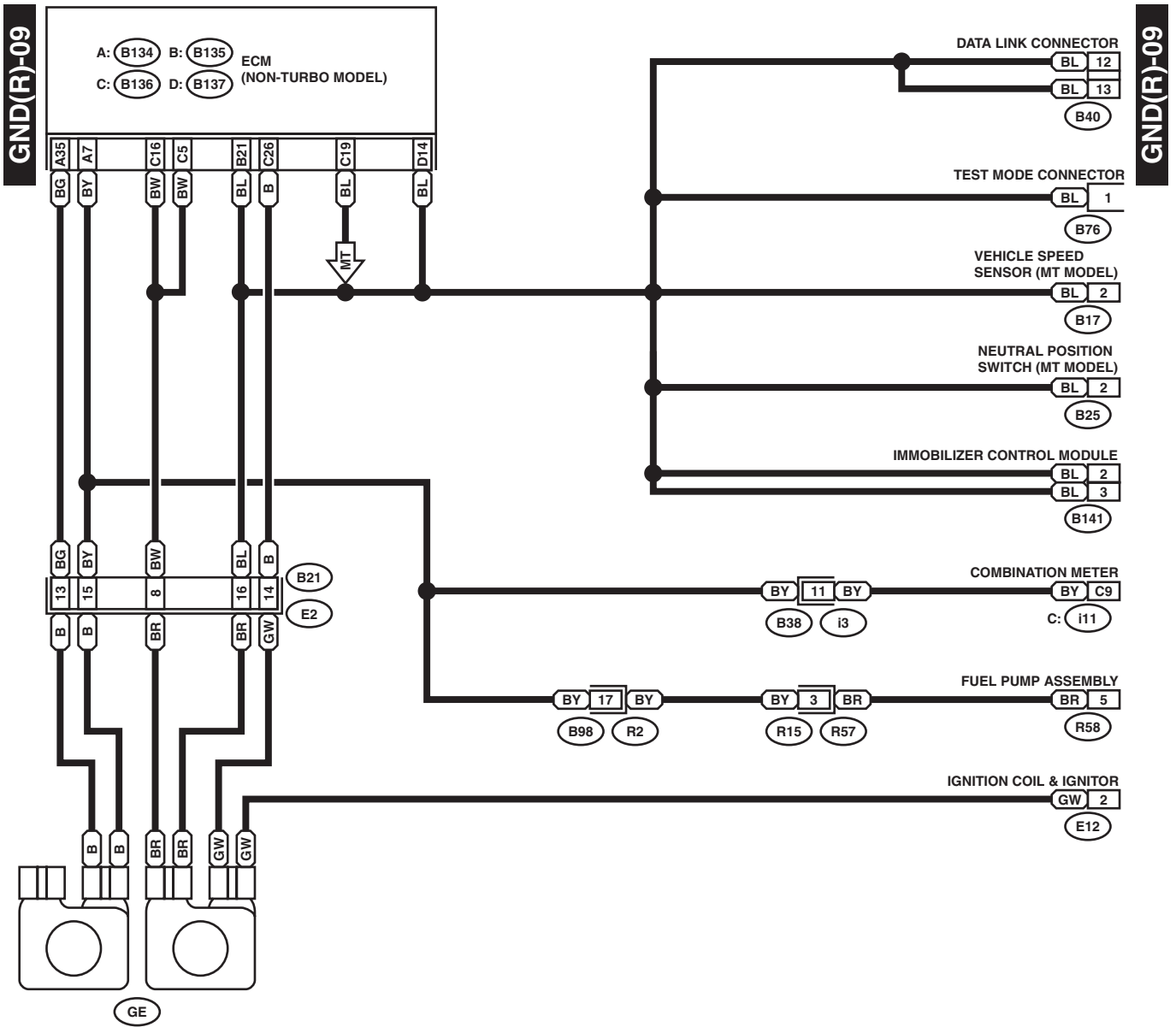

WI-03201

Ground Distribution

WIRING SYSTEM

9. TRANSMISSION GROUND RHD TURBO MODEL

GND(R)-10

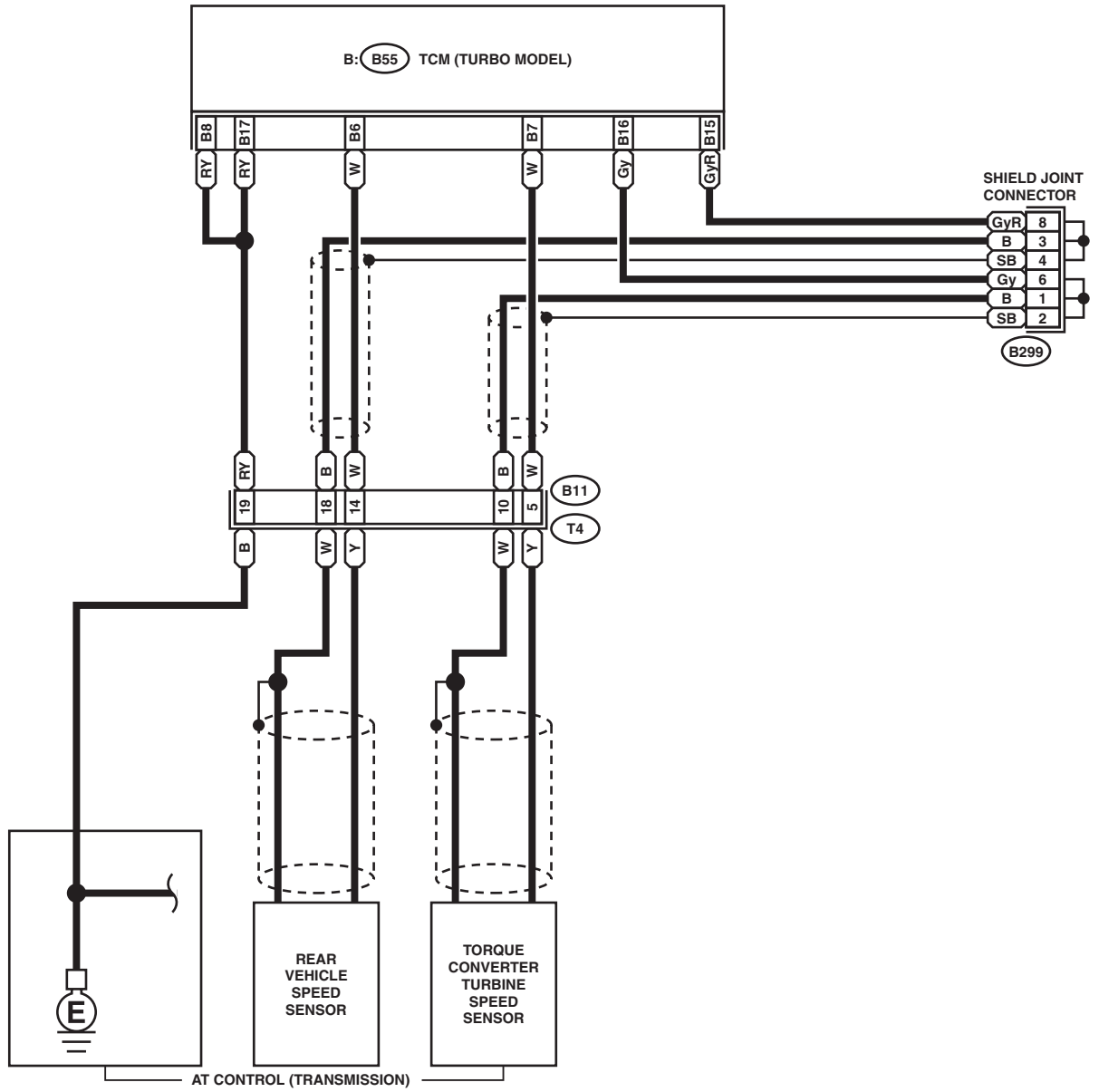

GND(R)-10

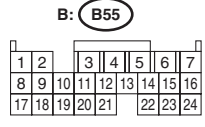
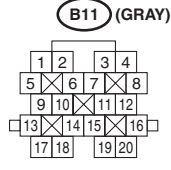

WI-03202

10. TRANSMISSION GROUND RHD NON-TURBO MODEL

GND(R)-11

GND(R)-11

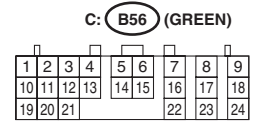
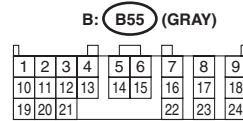
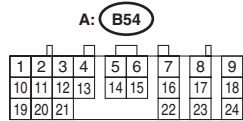
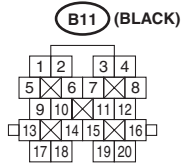
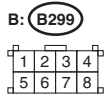
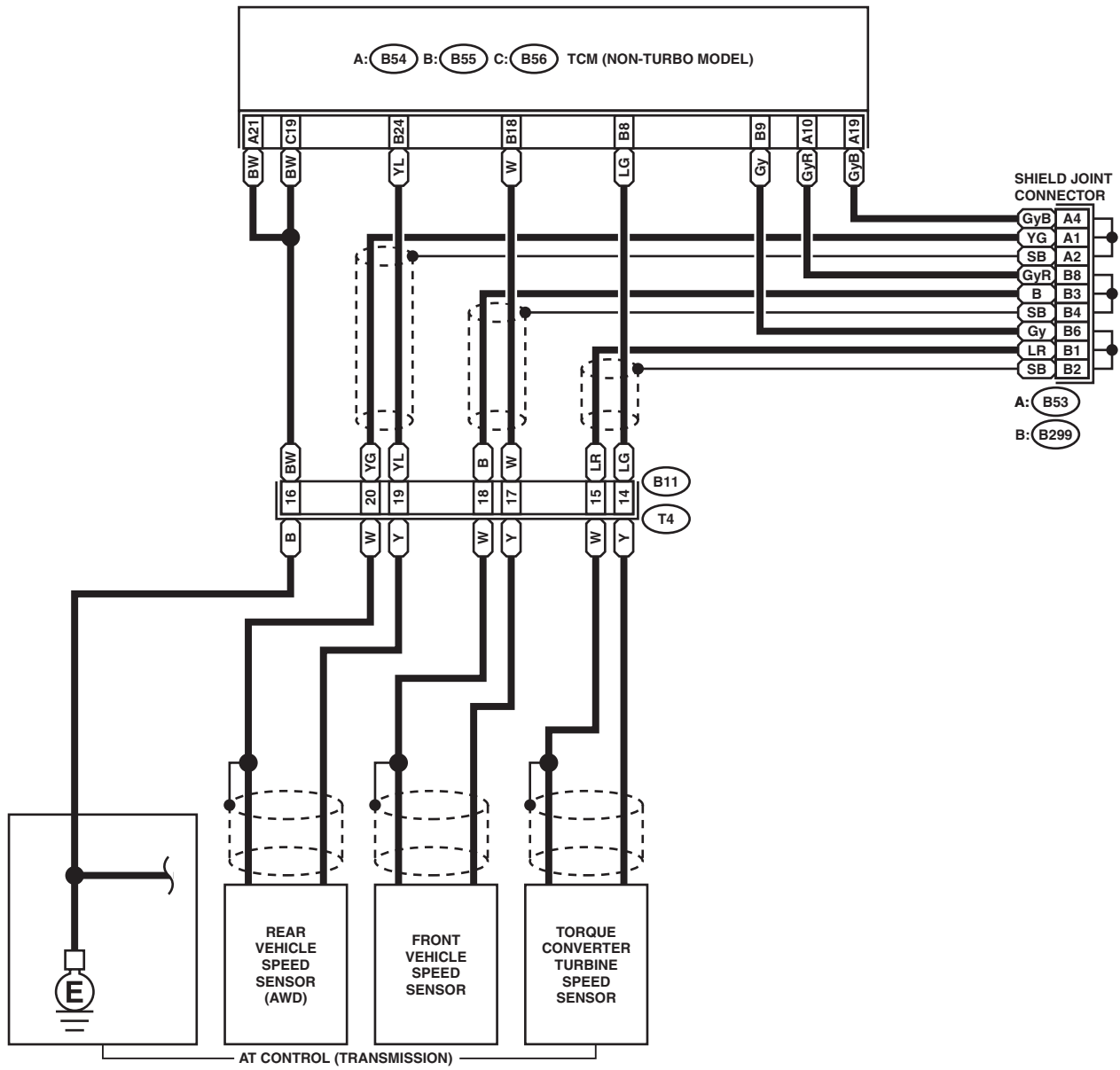

Airbag System

WIRING SYSTEM

5. Airbag System

A: WIRING DIAGRAM

1. LHD MODEL

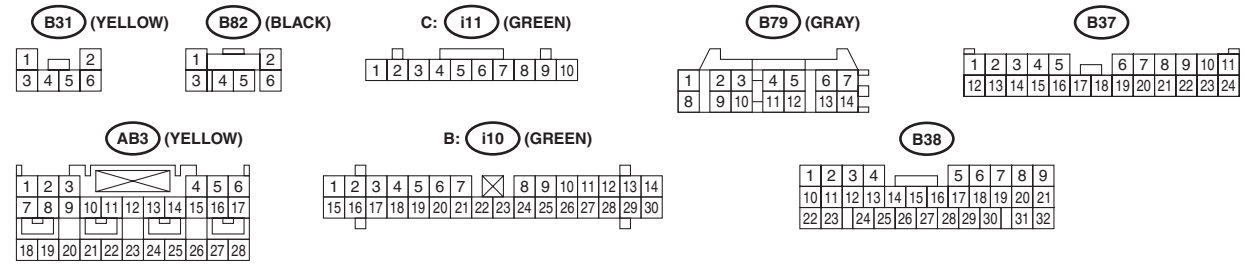
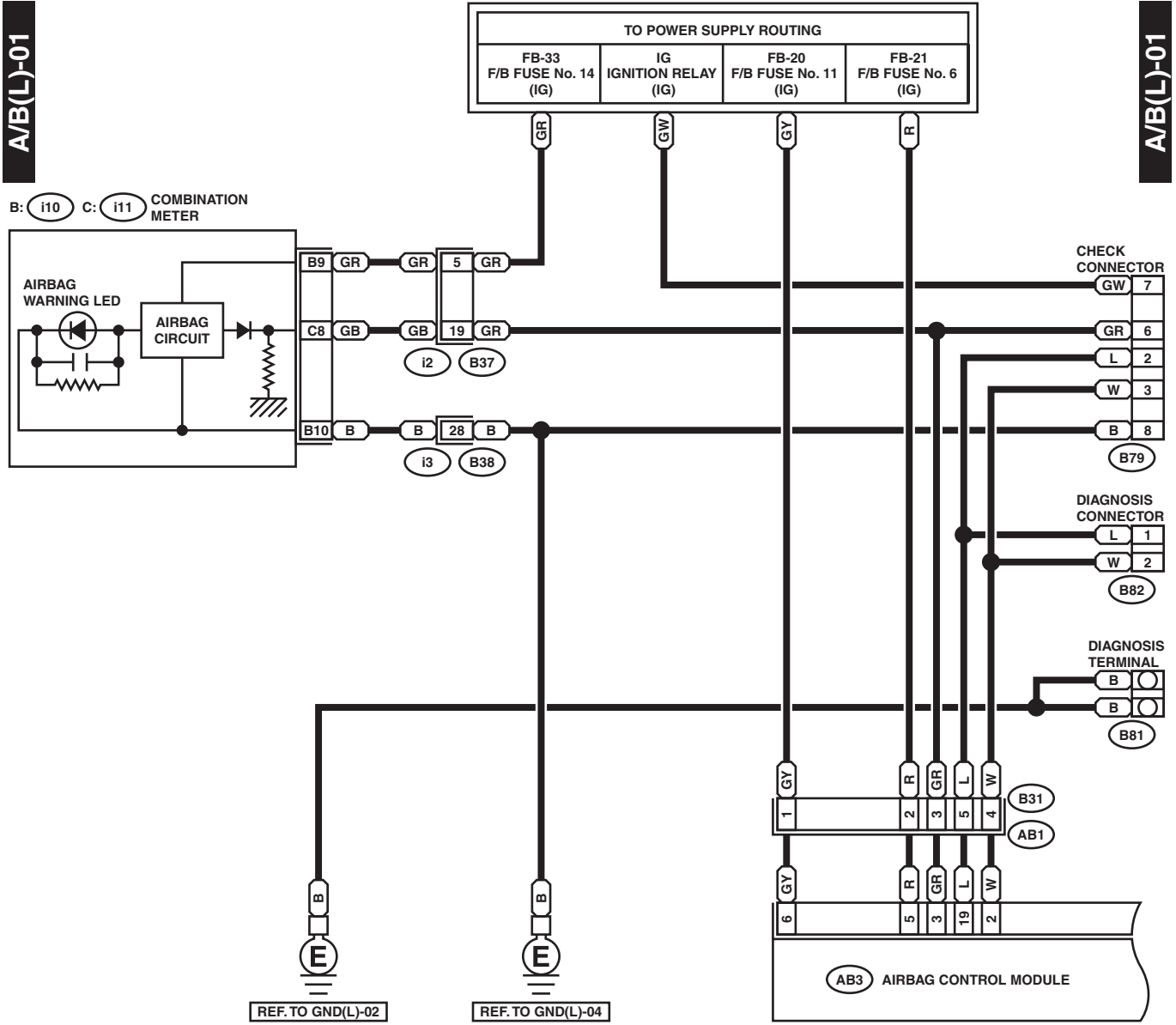

Airbag System

WIRING SYSTEM

A/B(L)-02

A/B(L)-02

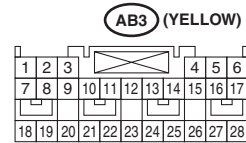
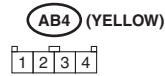
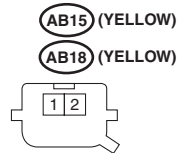
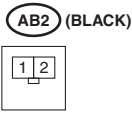
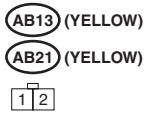
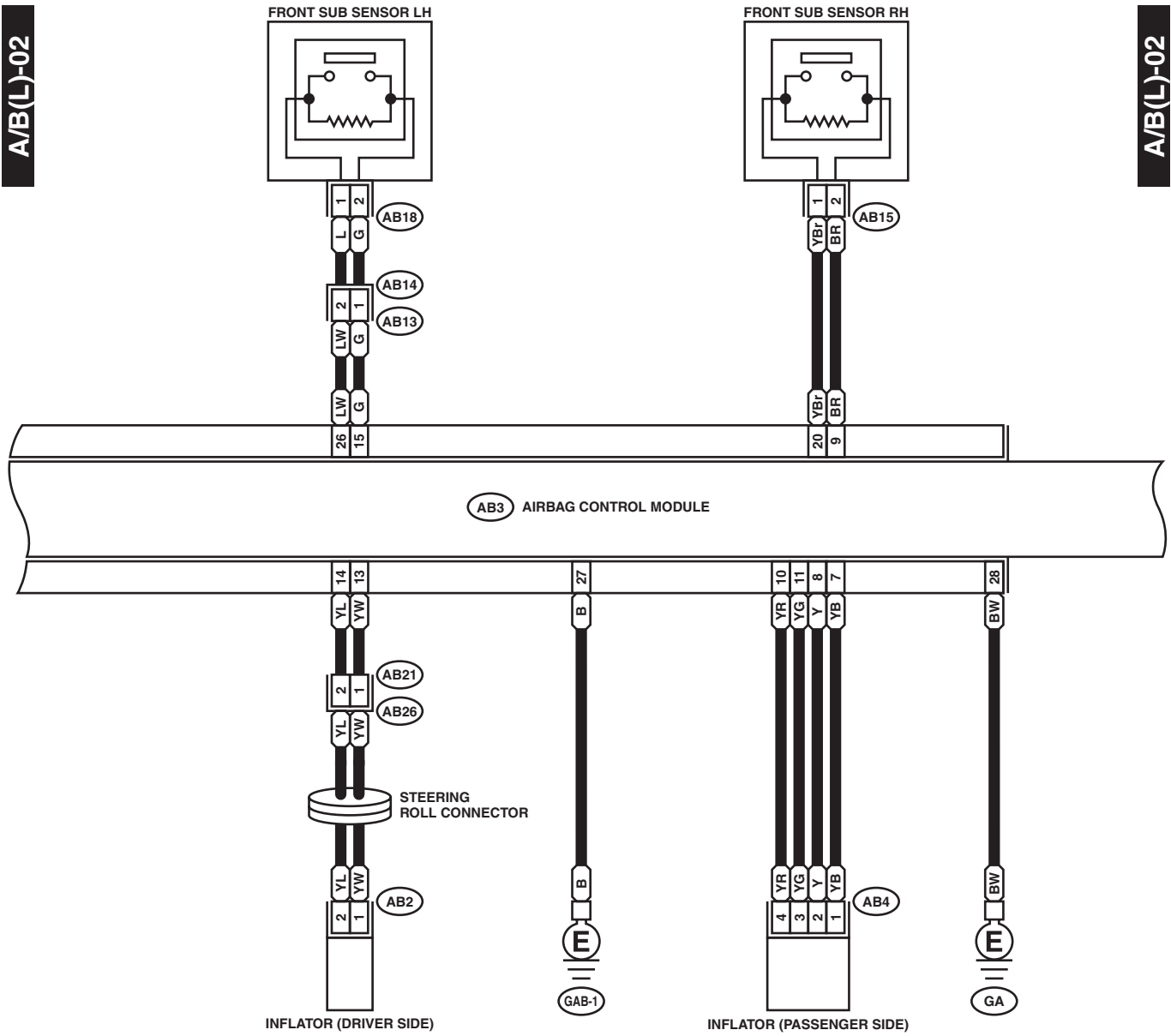

WI-03205

Airbag System

WIRING SYSTEM

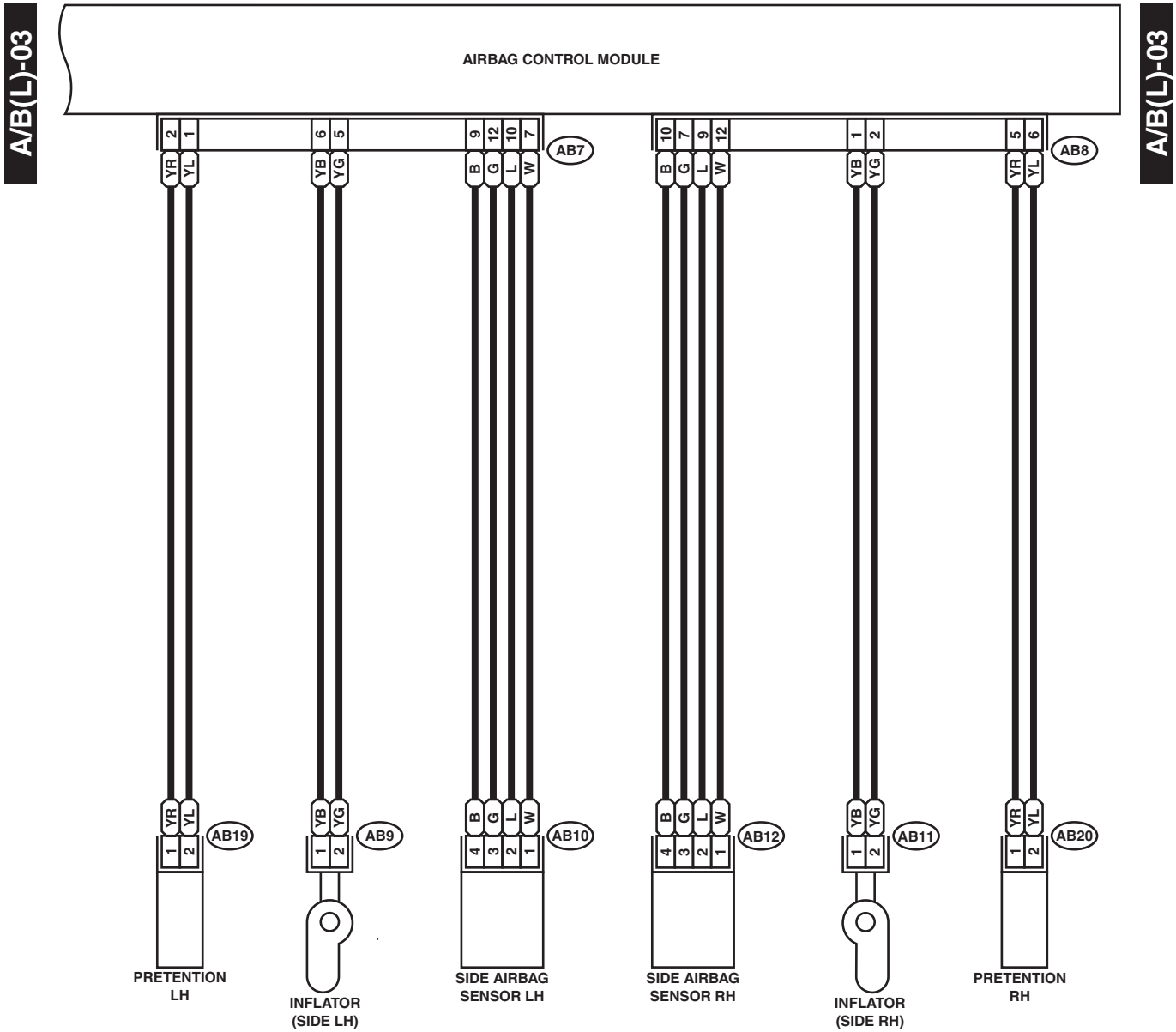

(YELLOW) AB9 AB11 (YELLOW)

(YELLOW) AB19 AB20 (YELLOW)



AB10 (YELLOW)

AB12 (YELLOW)

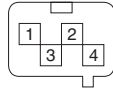

AB7 (YELLOW)

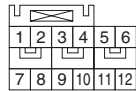

AB8 (YELLOW)

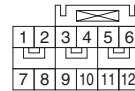

WI-00258

Airbag System

WIRING SYSTEM

2. RHD MODEL

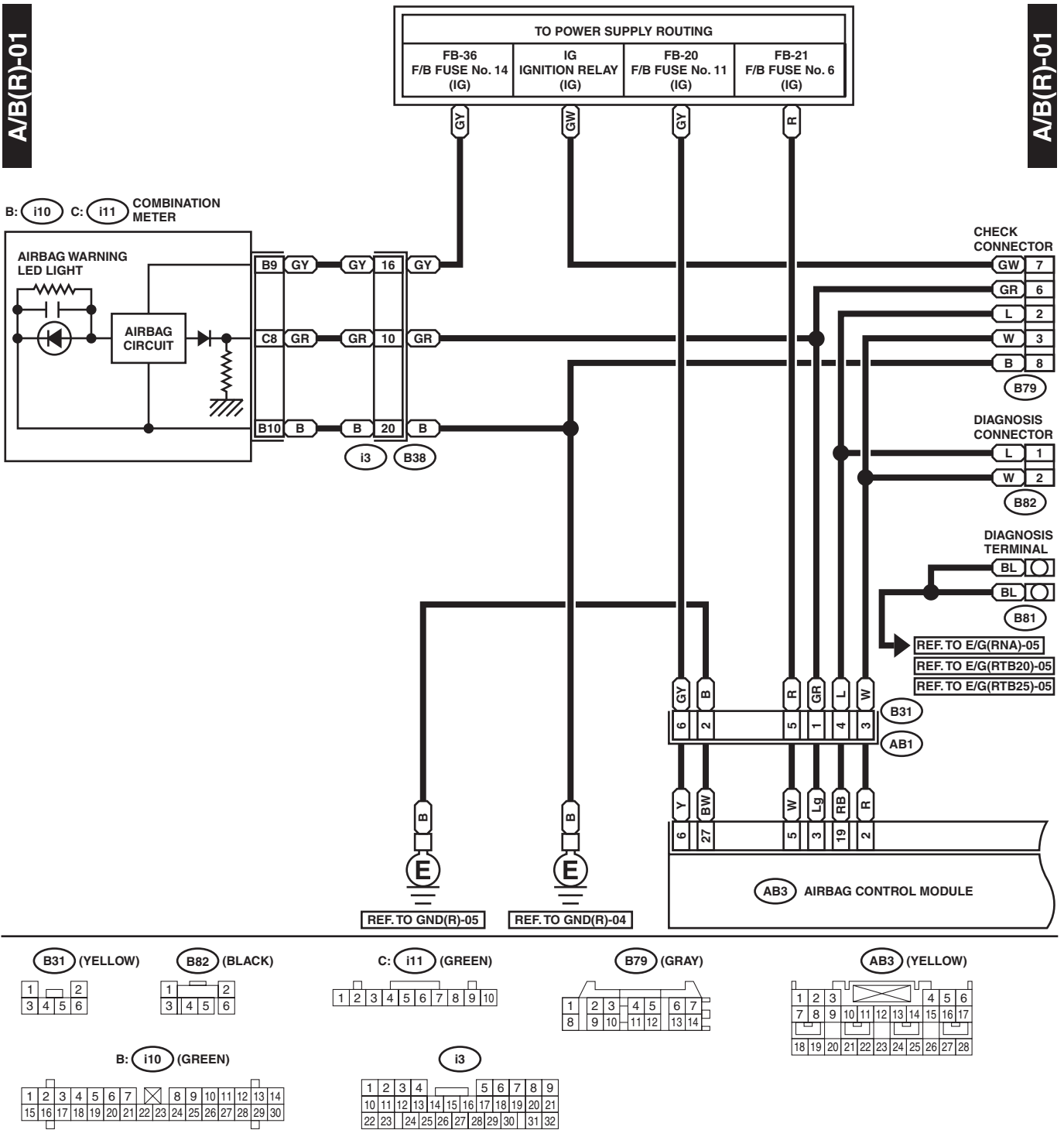

WI-03206

Airbag System

WIRING SYSTEM

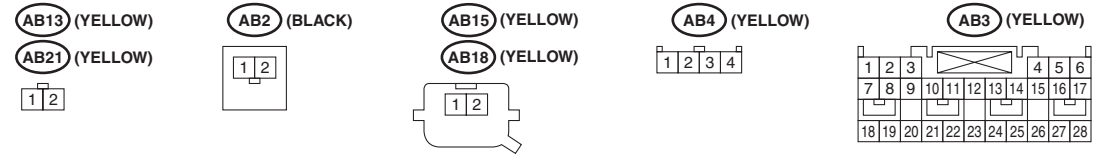
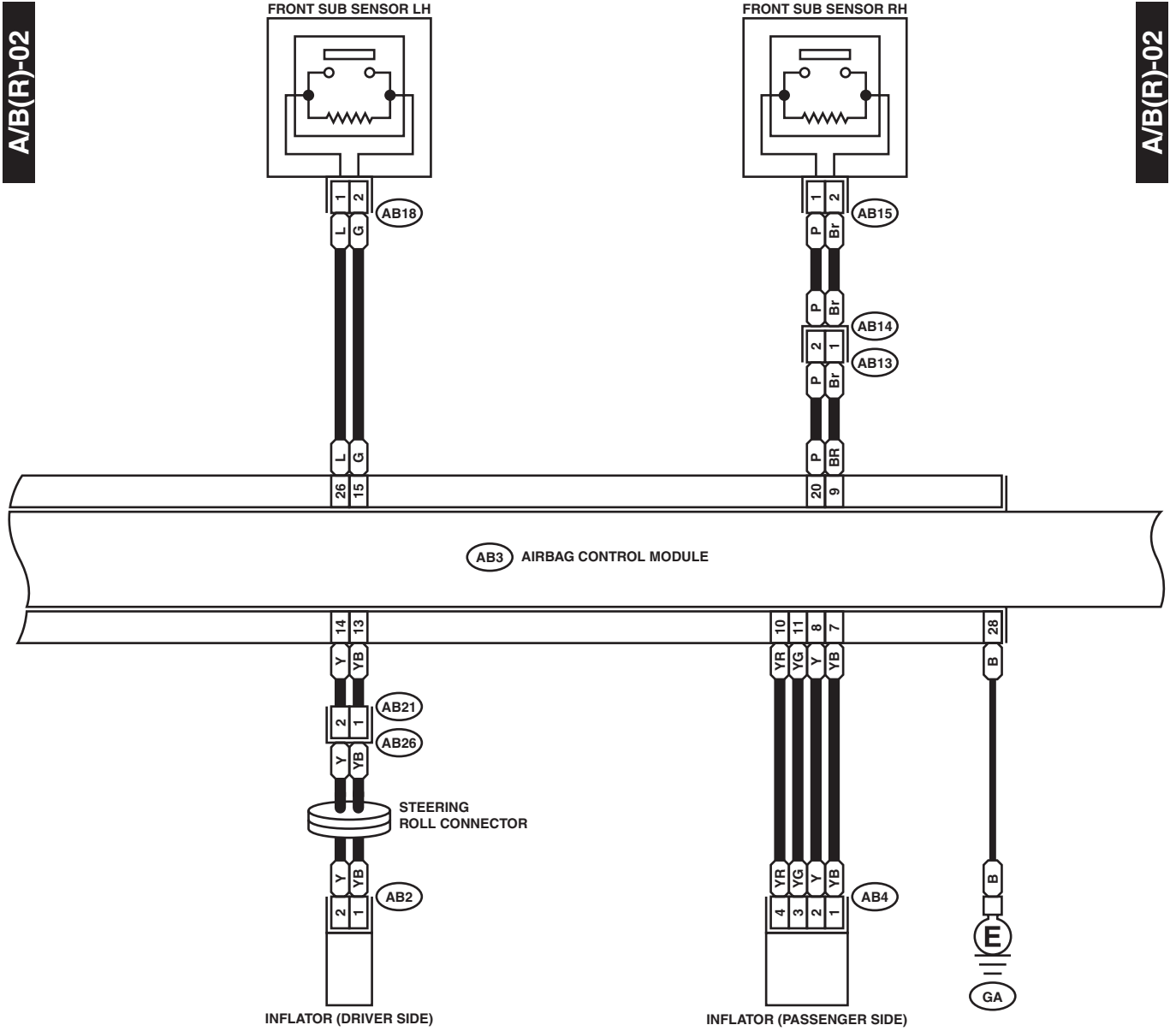

WI-03207

Airbag System

WIRING SYSTEM

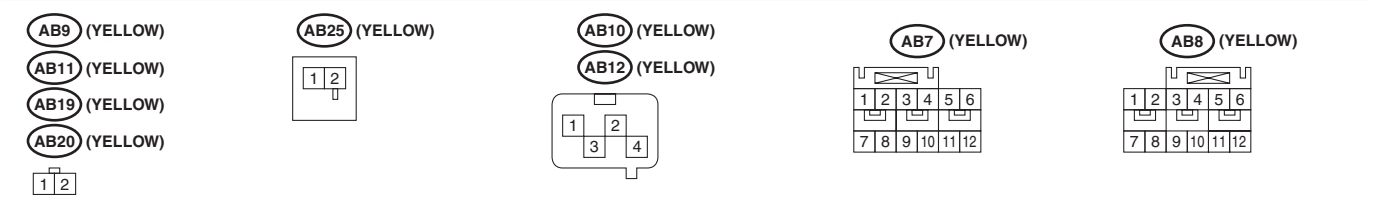
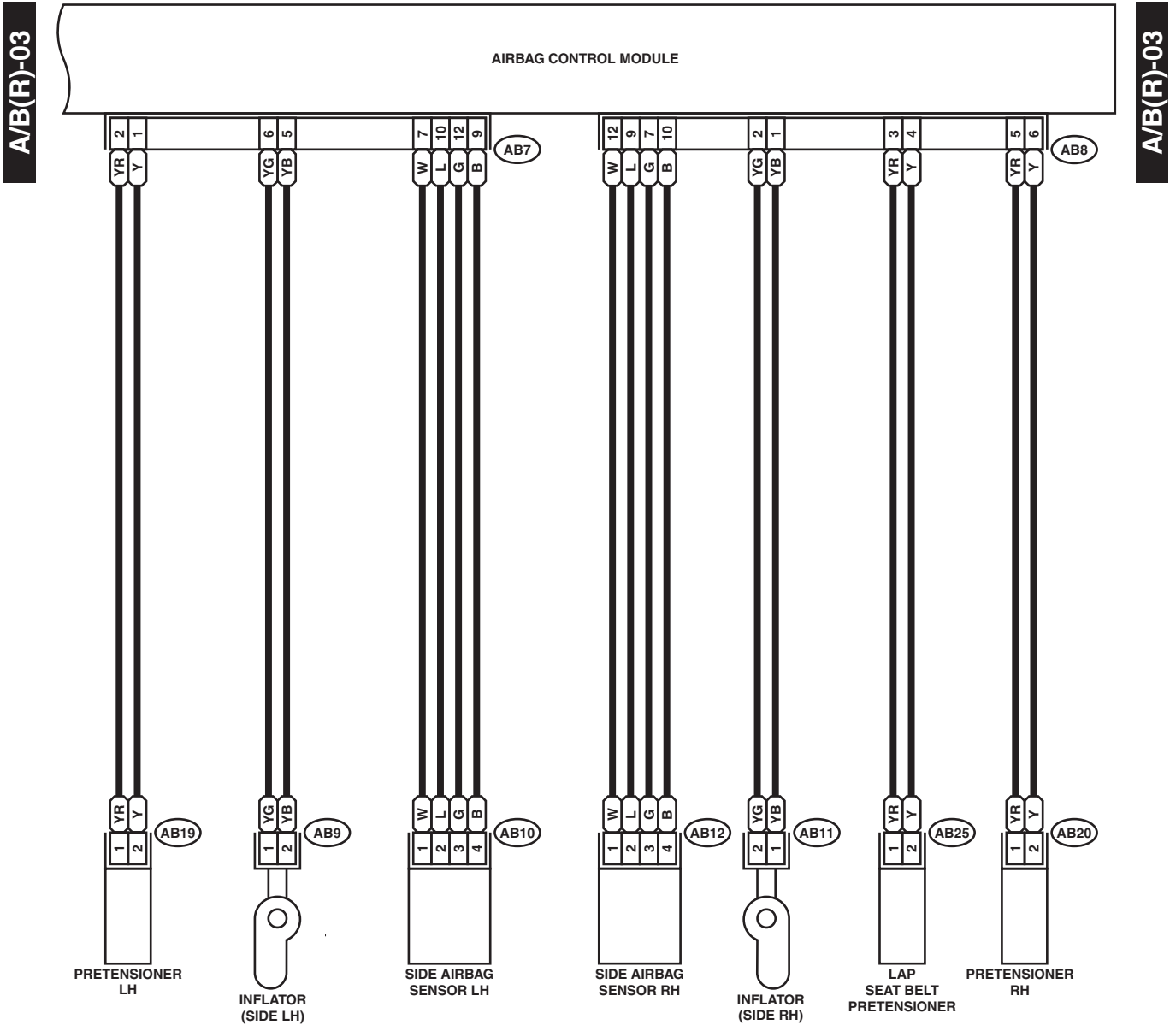

WI-03208

Air Conditioning System

WIRING SYSTEM

6. Air Conditioning System

A: WIRING DIAGRAM

1. MANUAL A/C LHD MODEL

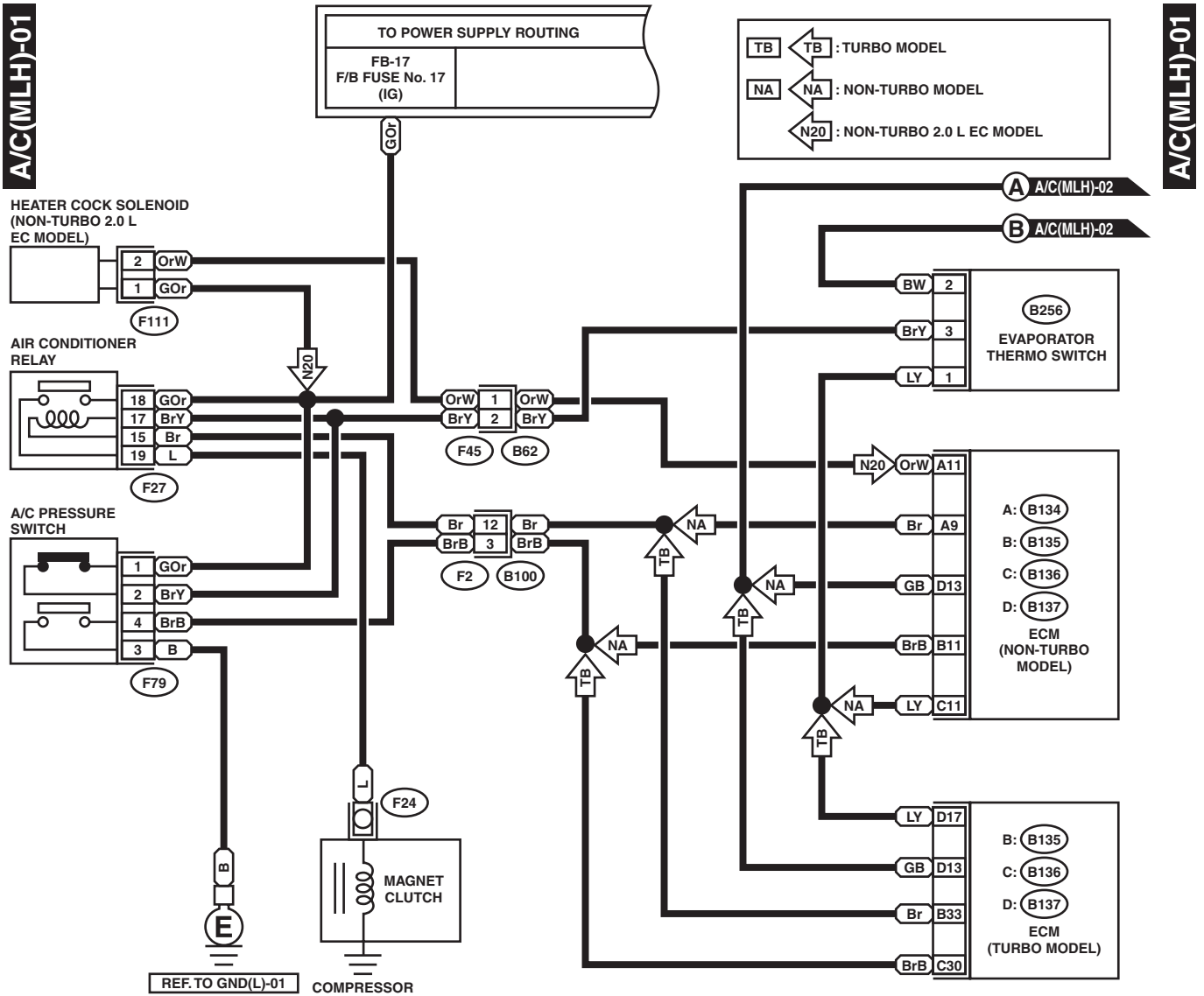

(F111) (GRAY)

(B256)

(F79)

(F45)

D: (B137) (GRAY) : NA

(F2) (BLUE)

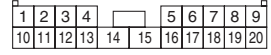
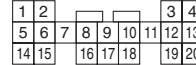
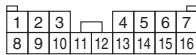

C: (B136) (GRAY) : NA

B: (B135) (GRAY) : NA

D: (B137) : TB

A: (B134) (GRAY) : NA

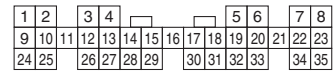
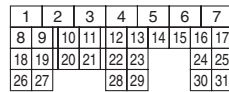
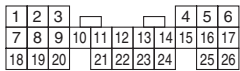

B: (B135) : TB

C: (B136) : TB

(F27)

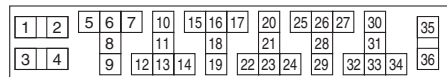
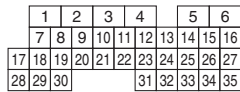
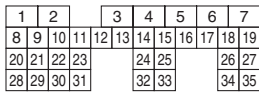

RELAY HOLDER

WI-03209

Air Conditioning System

WIRING SYSTEM

A/C(MLH)-02

A/C(MLH)-02

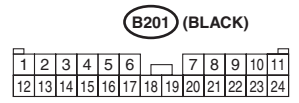
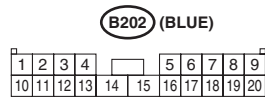
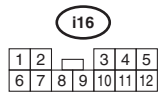
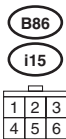
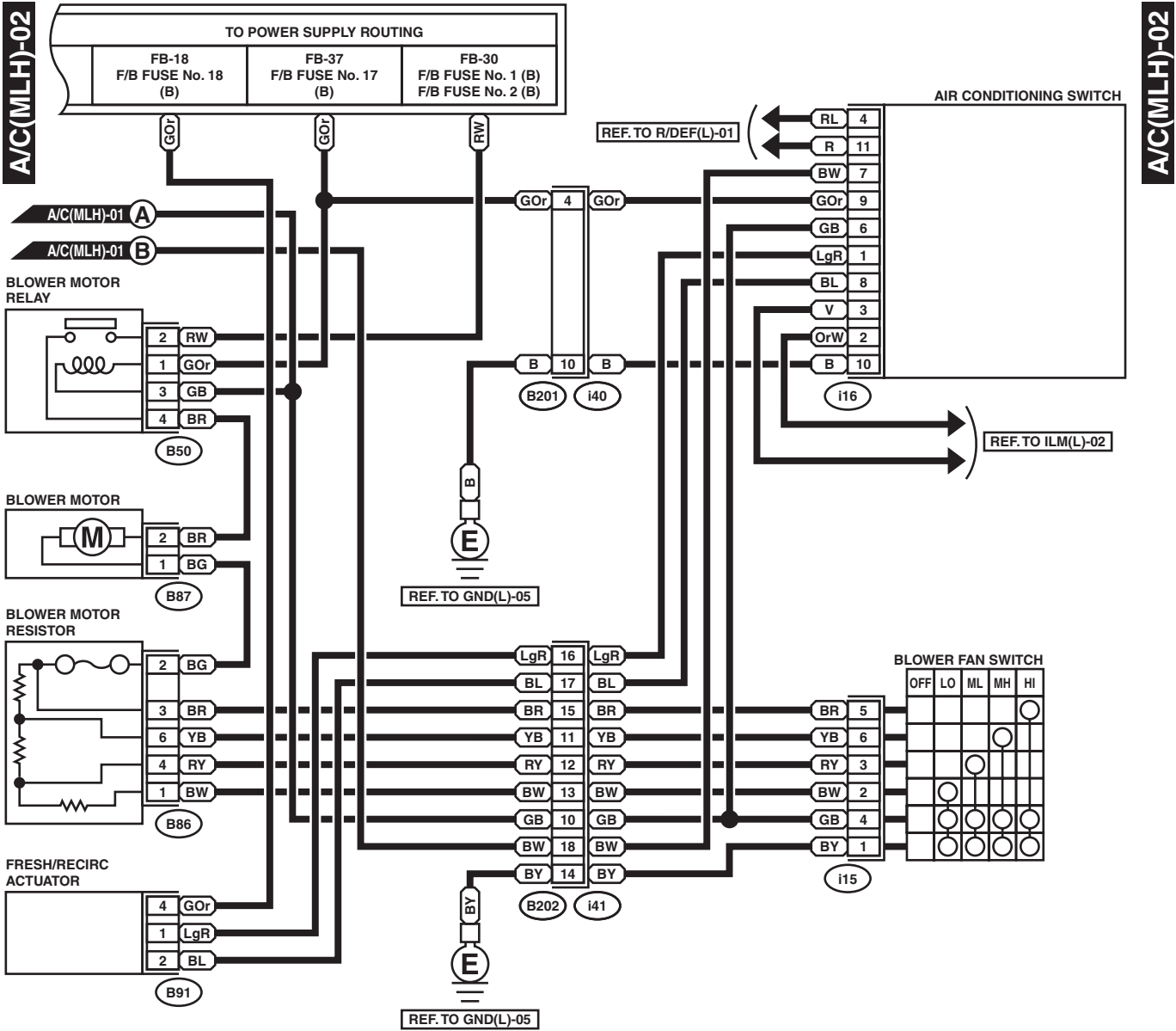

WI-03210

Air Conditioning System

WIRING SYSTEM

2. MANUAL A/C RHD MODEL

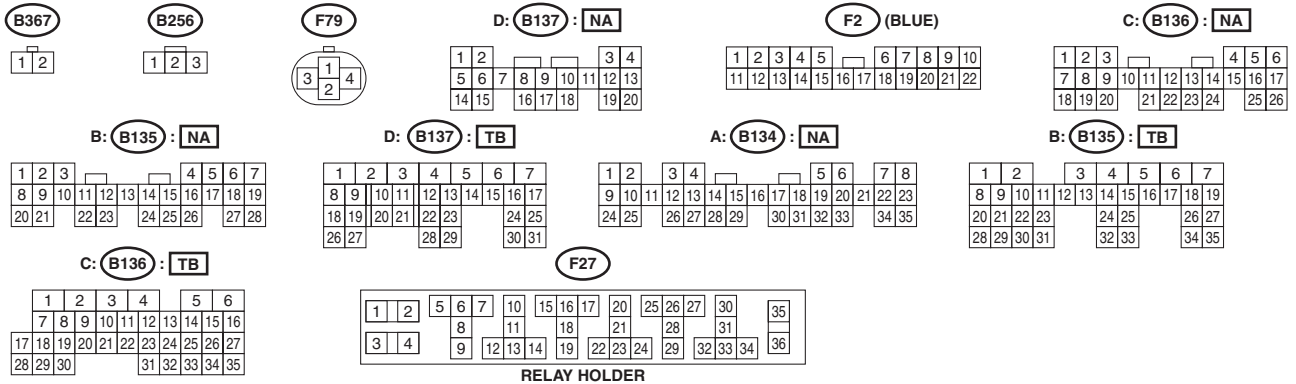
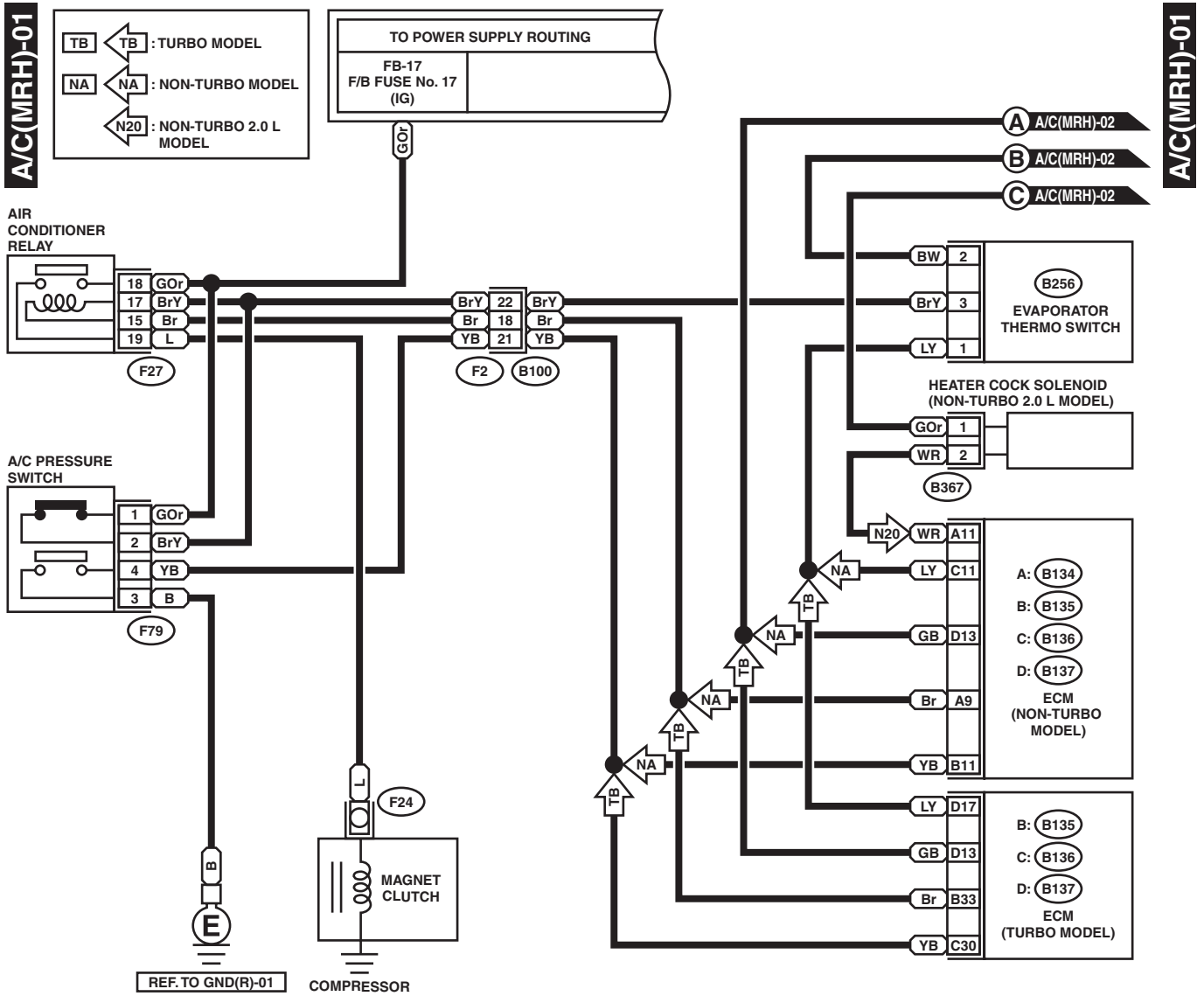

WI-03211

Air Conditioning System

WIRING SYSTEM

A/C(MRH)-02

A/C(MRH)-02

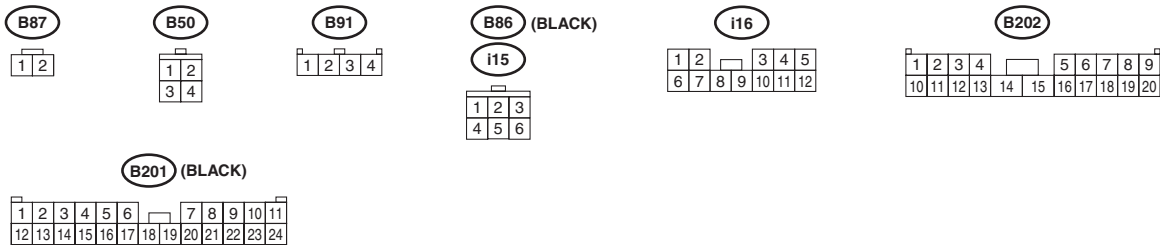
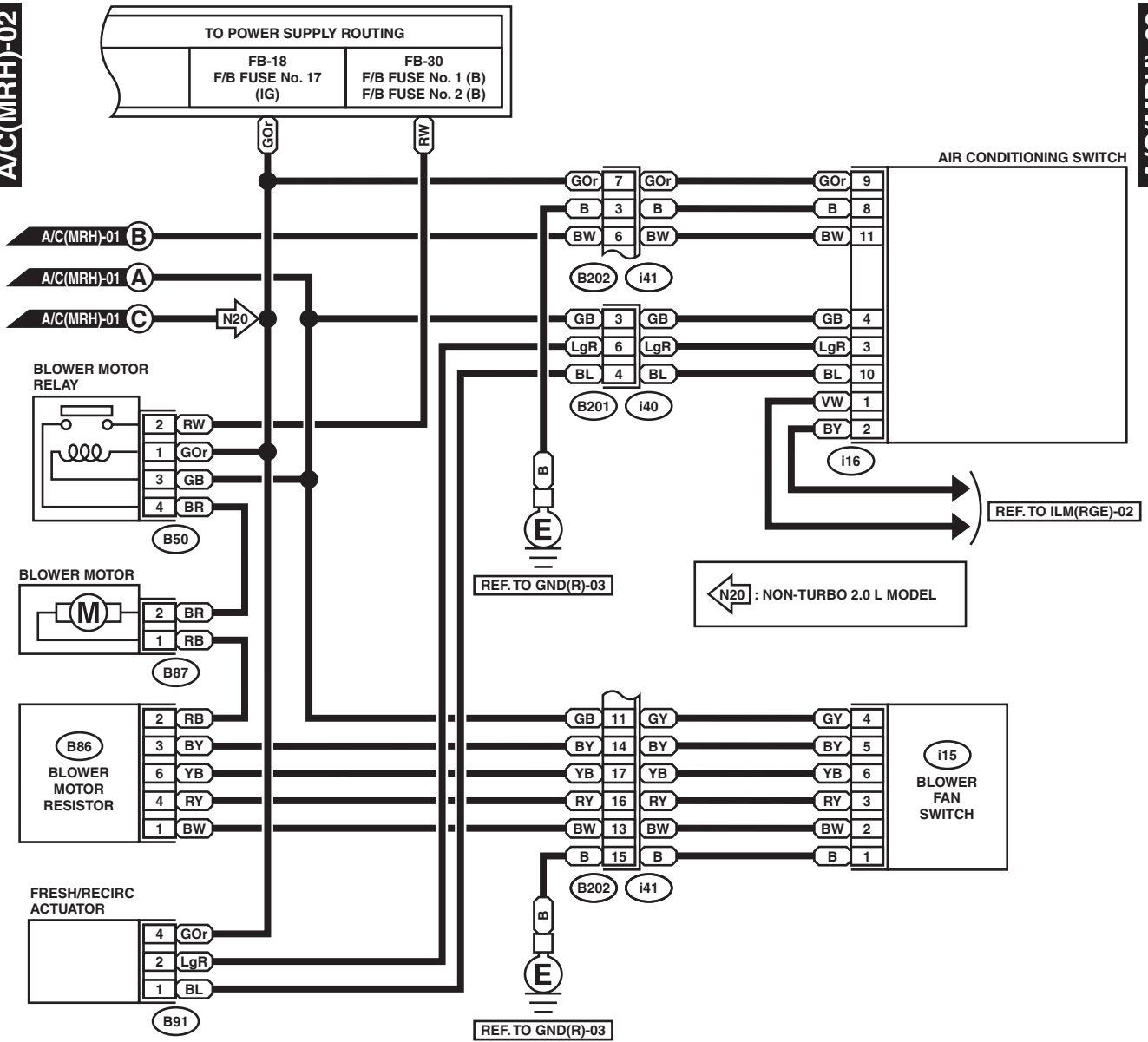

WI-03212

Air Conditioning System

WIRING SYSTEM

3. AUTO A/C LHD MODEL

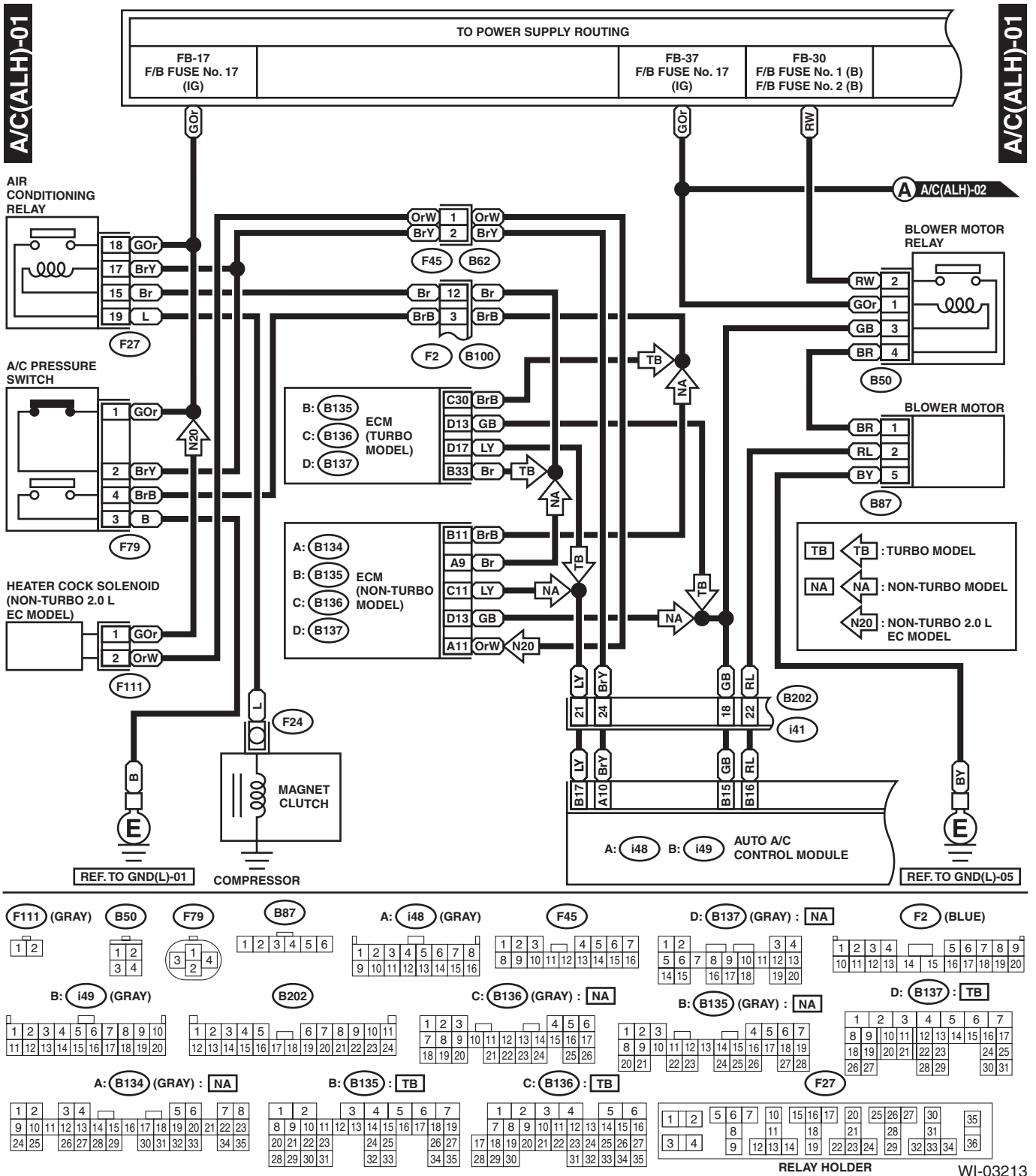

Air Conditioning System

WIRING SYSTEM

A/C(ALH)-02

A/C(ALH)-02

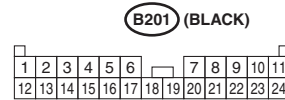
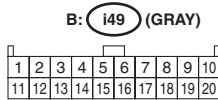
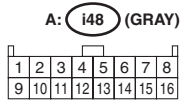
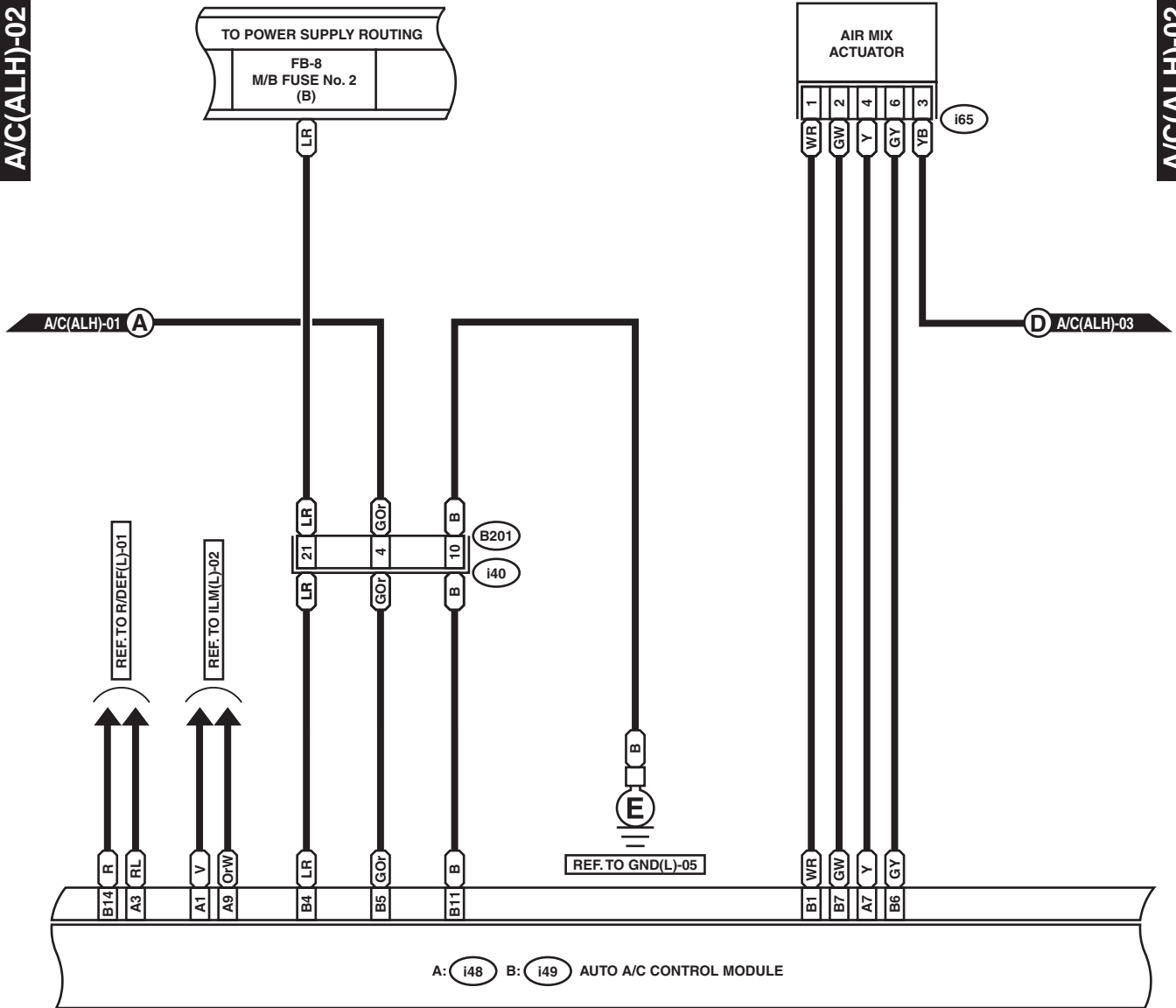

WI-03214

Air Conditioning System

WIRING SYSTEM

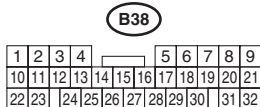
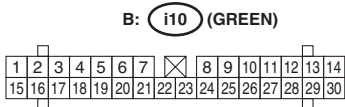
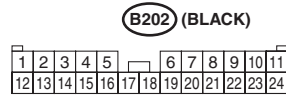
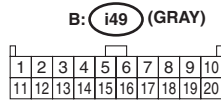
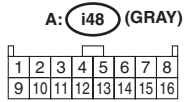
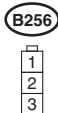
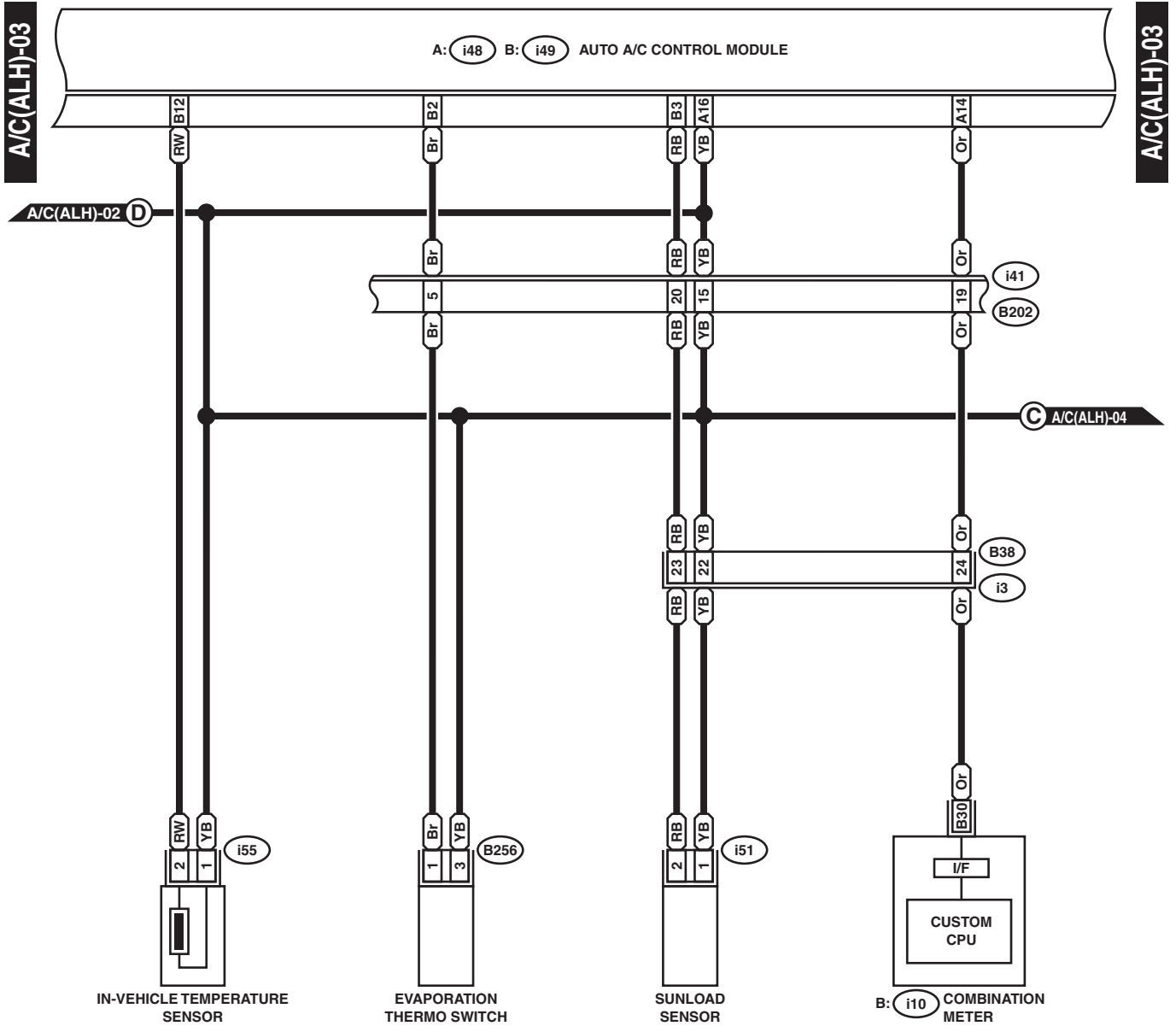

WI-00274

Air Conditioning System

WIRING SYSTEM

A/C(ALH)-04

A/C(ALH)-04

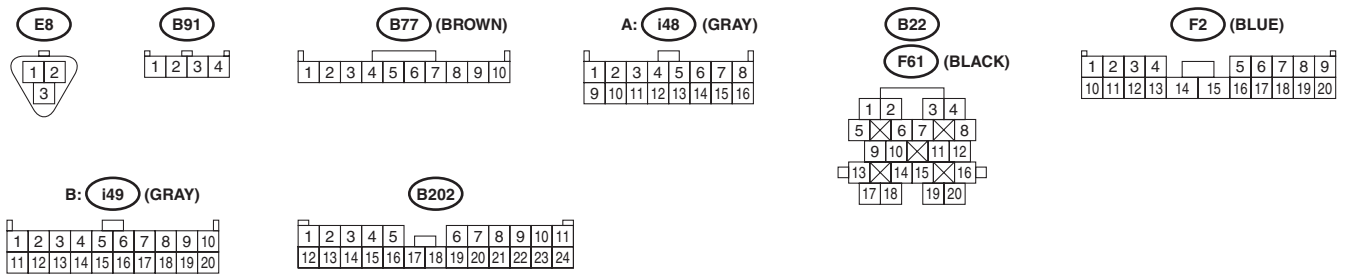
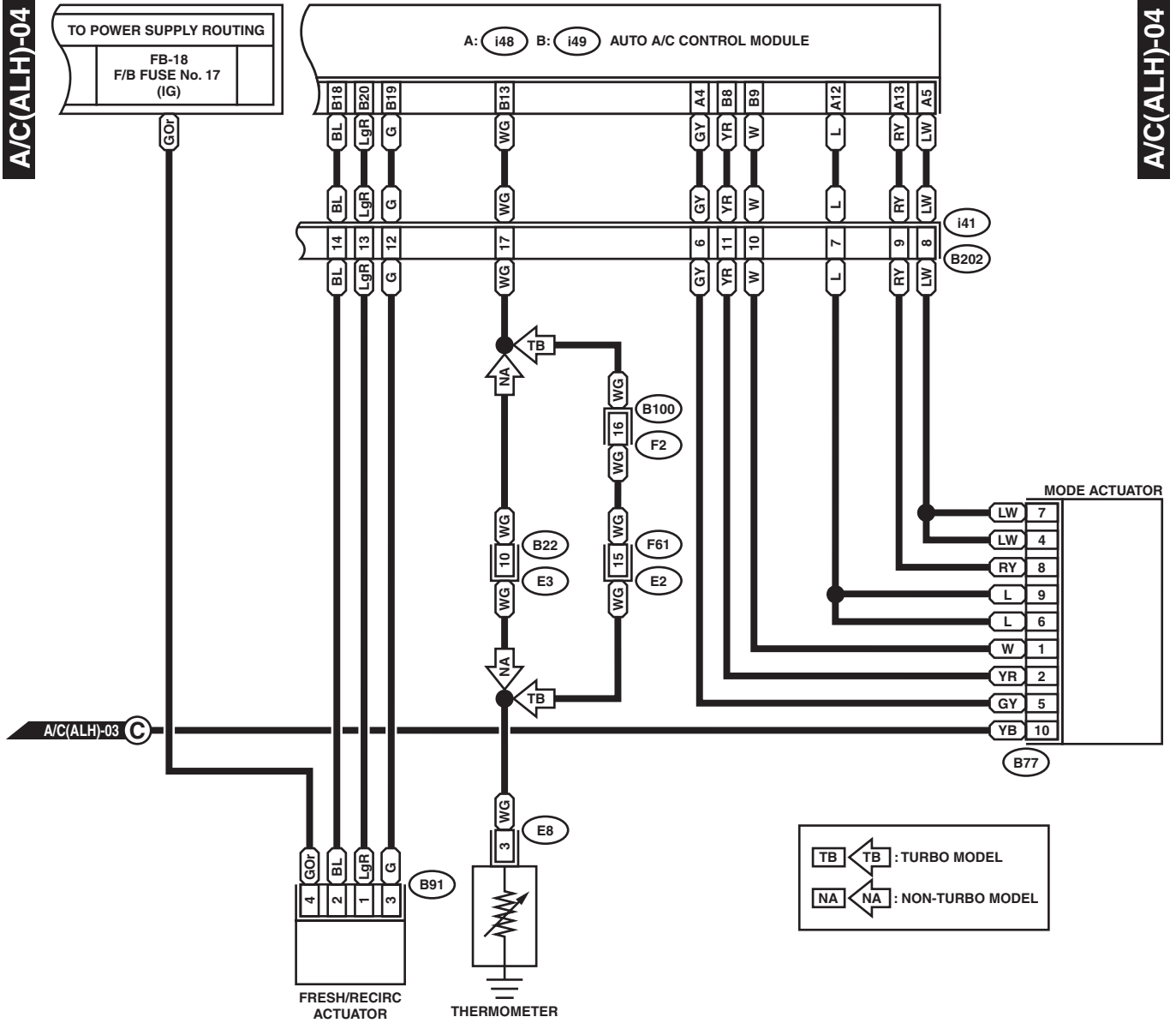

WI-03215

Air Conditioning System

WIRING SYSTEM

4. AUTO A/C RHD MODEL

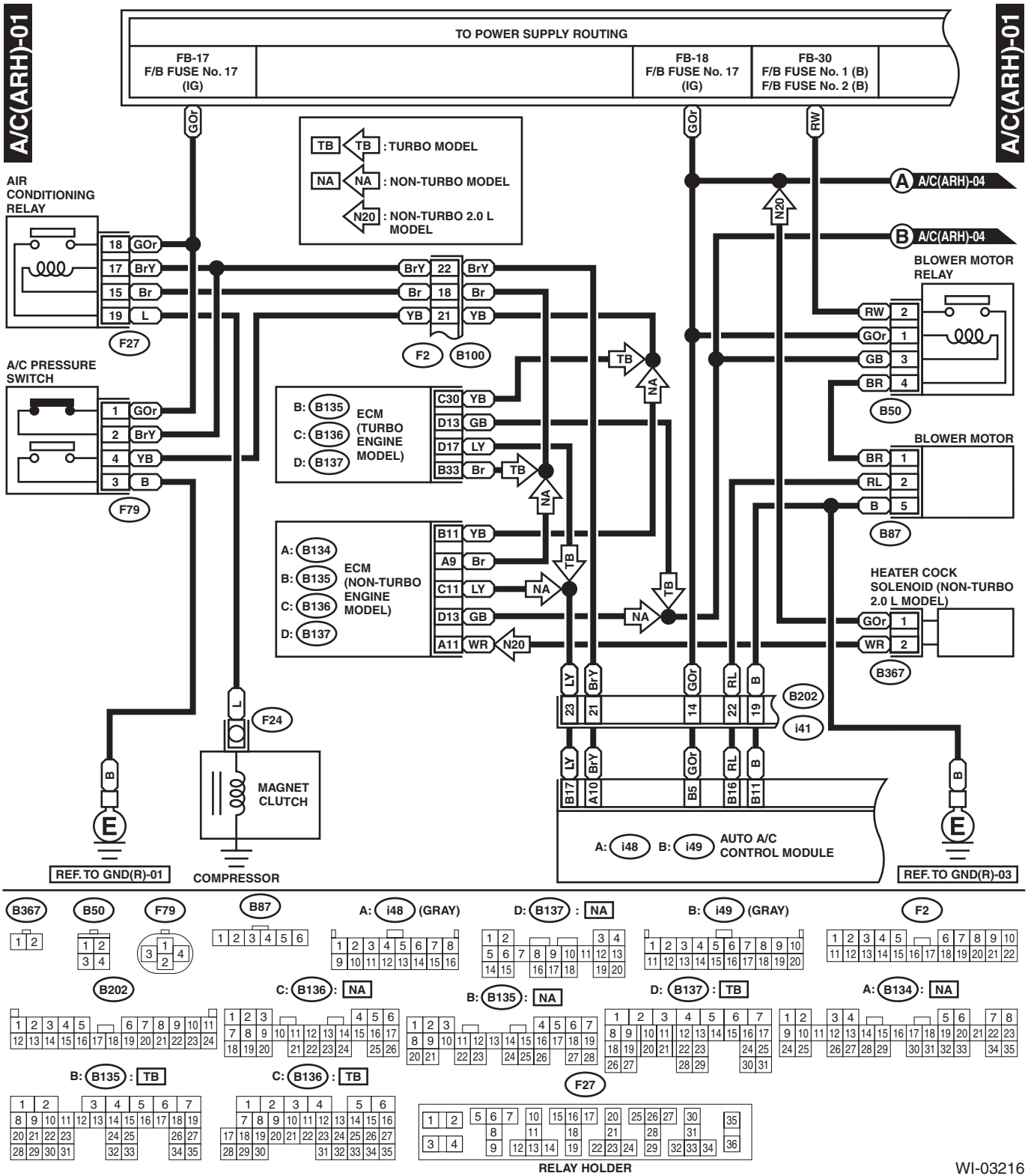

WI-03216

Air Conditioning System

WIRING SYSTEM

A/C(ARH)-02

A/C(ARH)-02

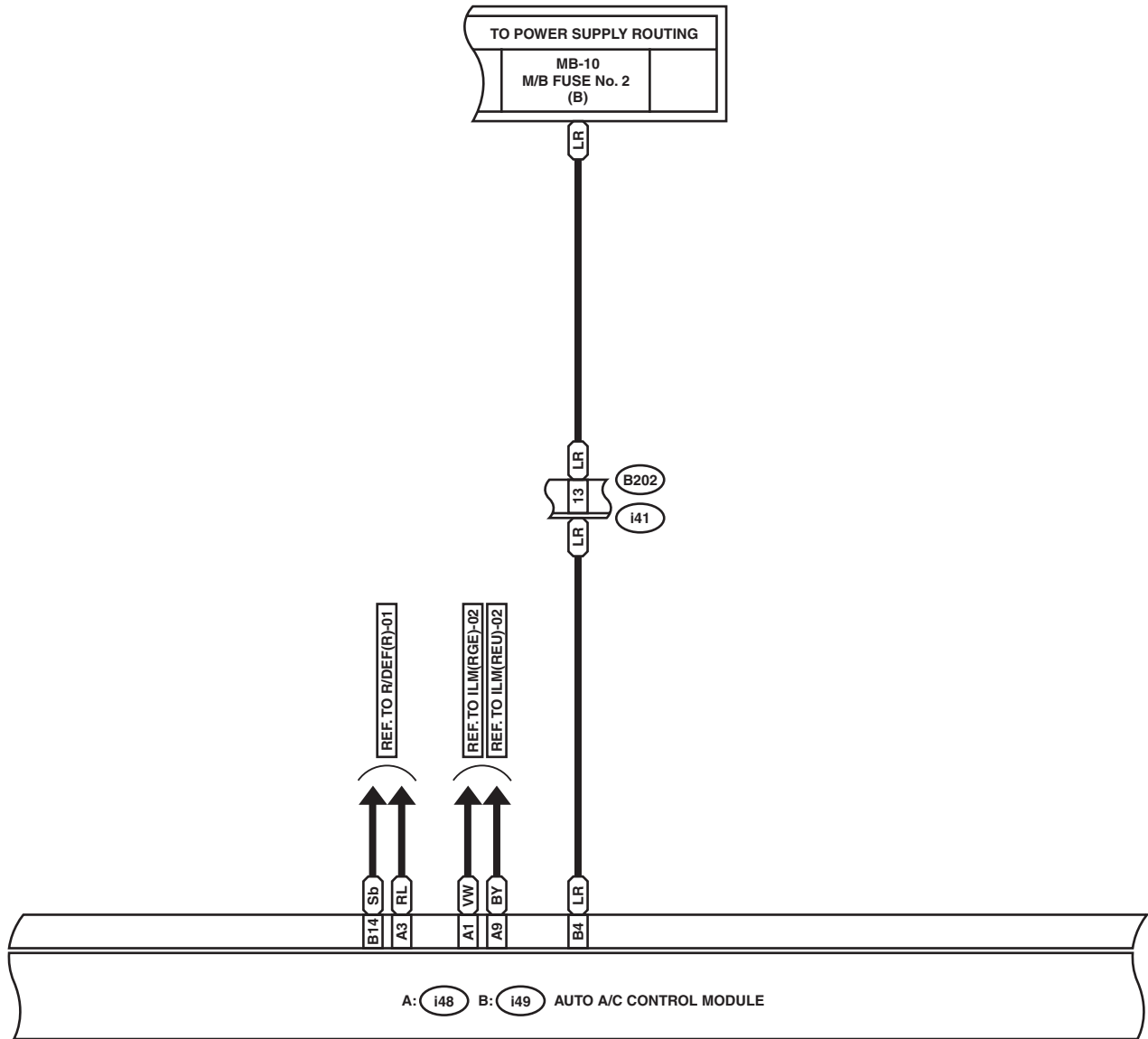

A: i48 (GRAY)

1	2	3	4	5	6	7	8
9	10	11	12	13	14	15	16

B: i49 (GRAY)

1	2	3	4	5	6	7	8	9	10
11	12	13	14	15	16	17	18	19	20

B202

1	2	3	4	5	6	7	8	9	10	11		
12	13	14	15	16	17	18	19	20	21	22	23	24

WI-03217

Air Conditioning System

WIRING SYSTEM

A/C(ARH)-03

A/C(ARH)-03

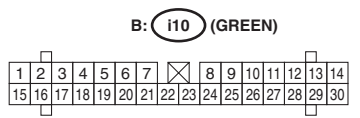
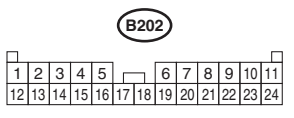
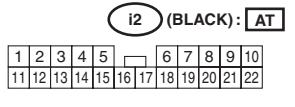
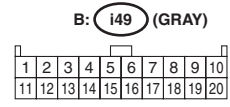
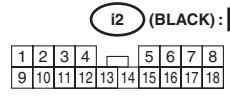
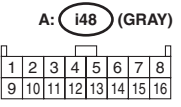
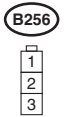
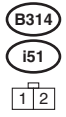
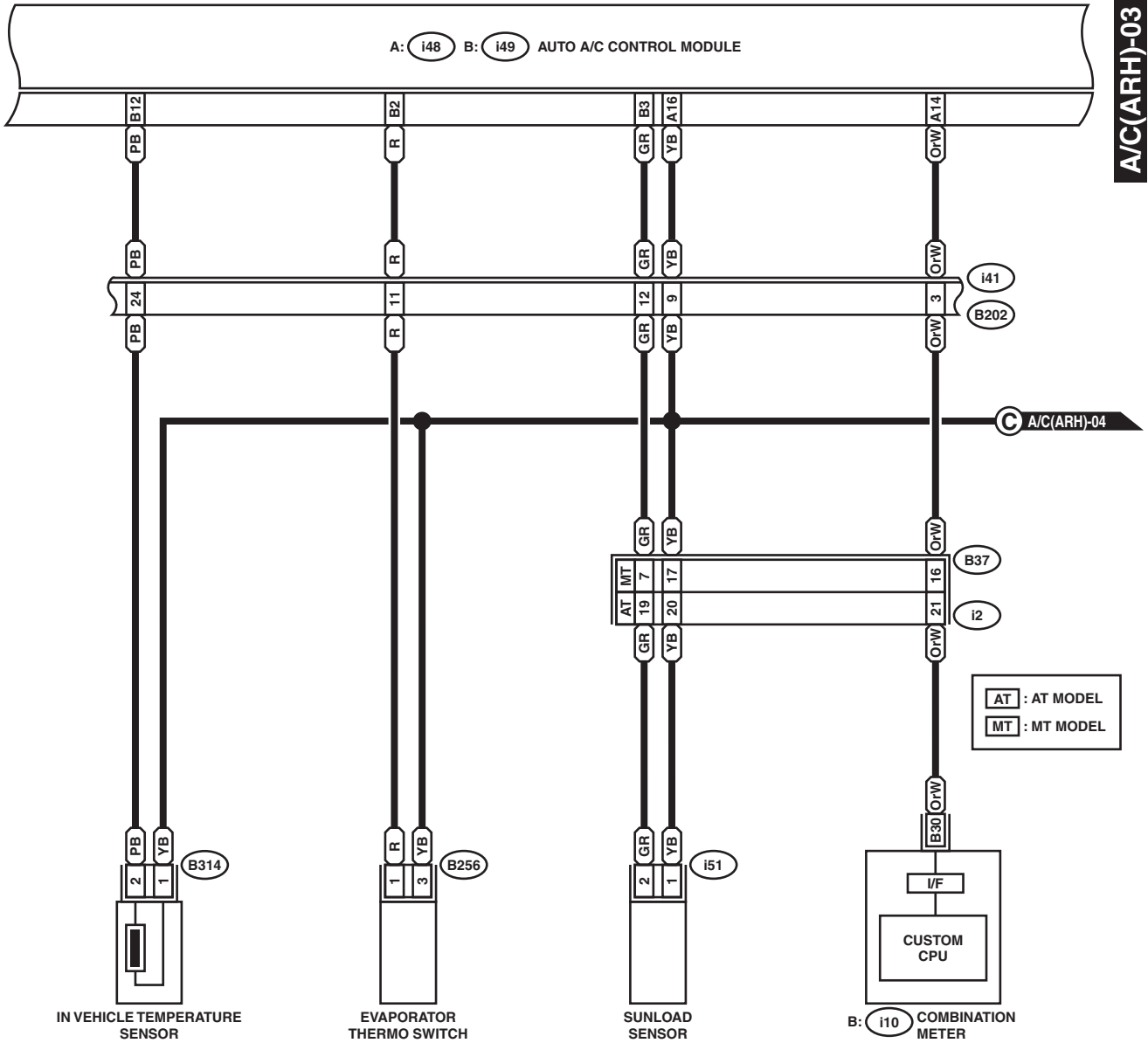

WI-03218

Air Conditioning System

WIRING SYSTEM

A/C(ARH)-04

A/C(ARH)-04

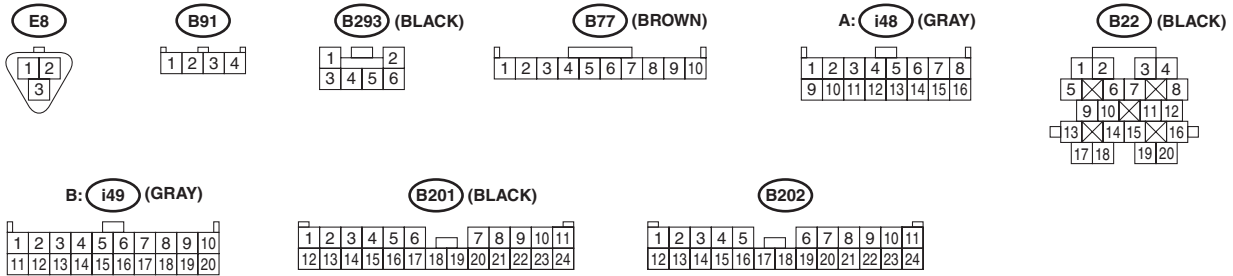
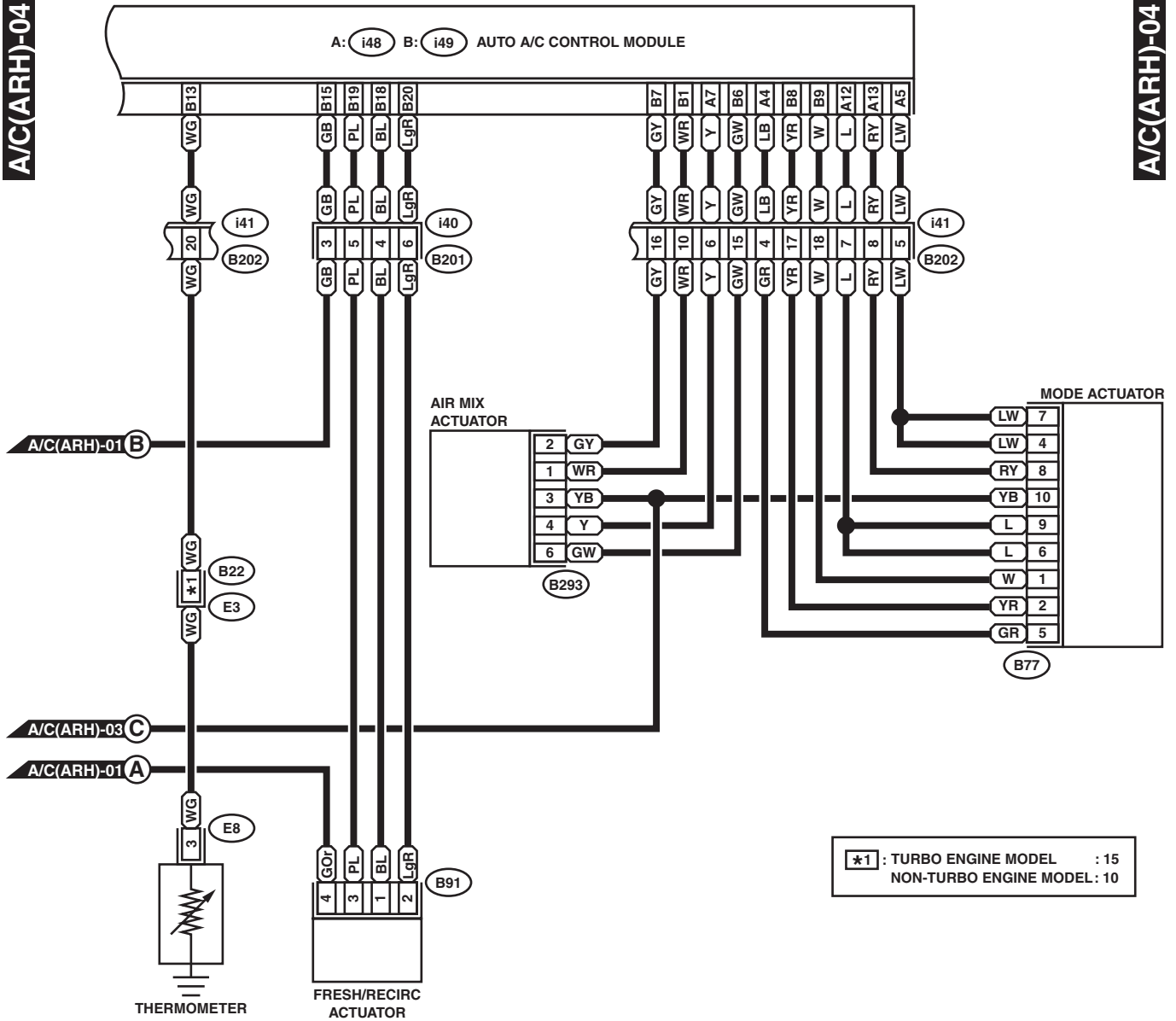

WI-00279

Anti-lock Brake System

WIRING SYSTEM

7. Anti-lock Brake System

A: WIRING DIAGRAM

1. LHD MODEL

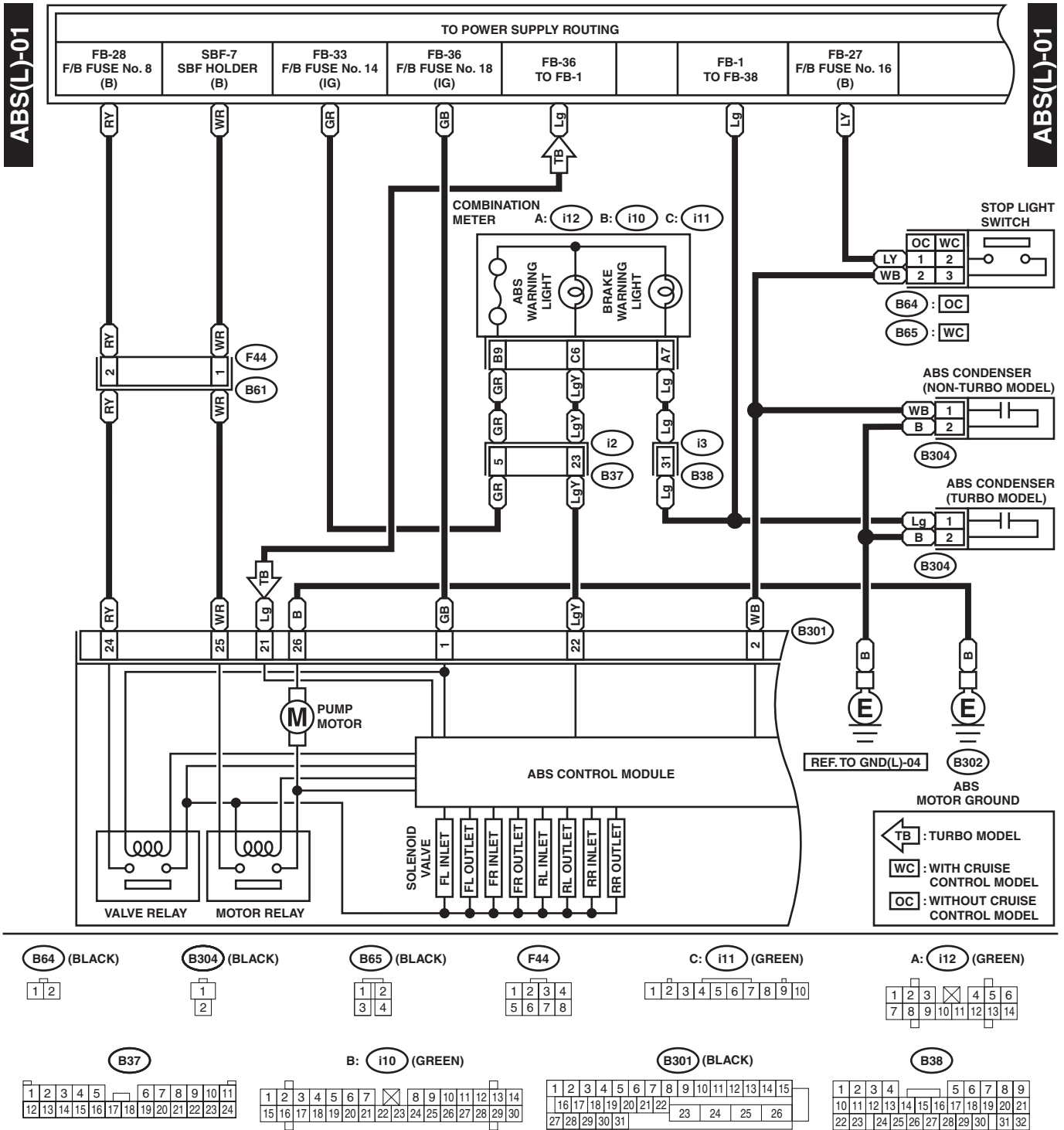

WI-03219

Anti-lock Brake System

WIRING SYSTEM

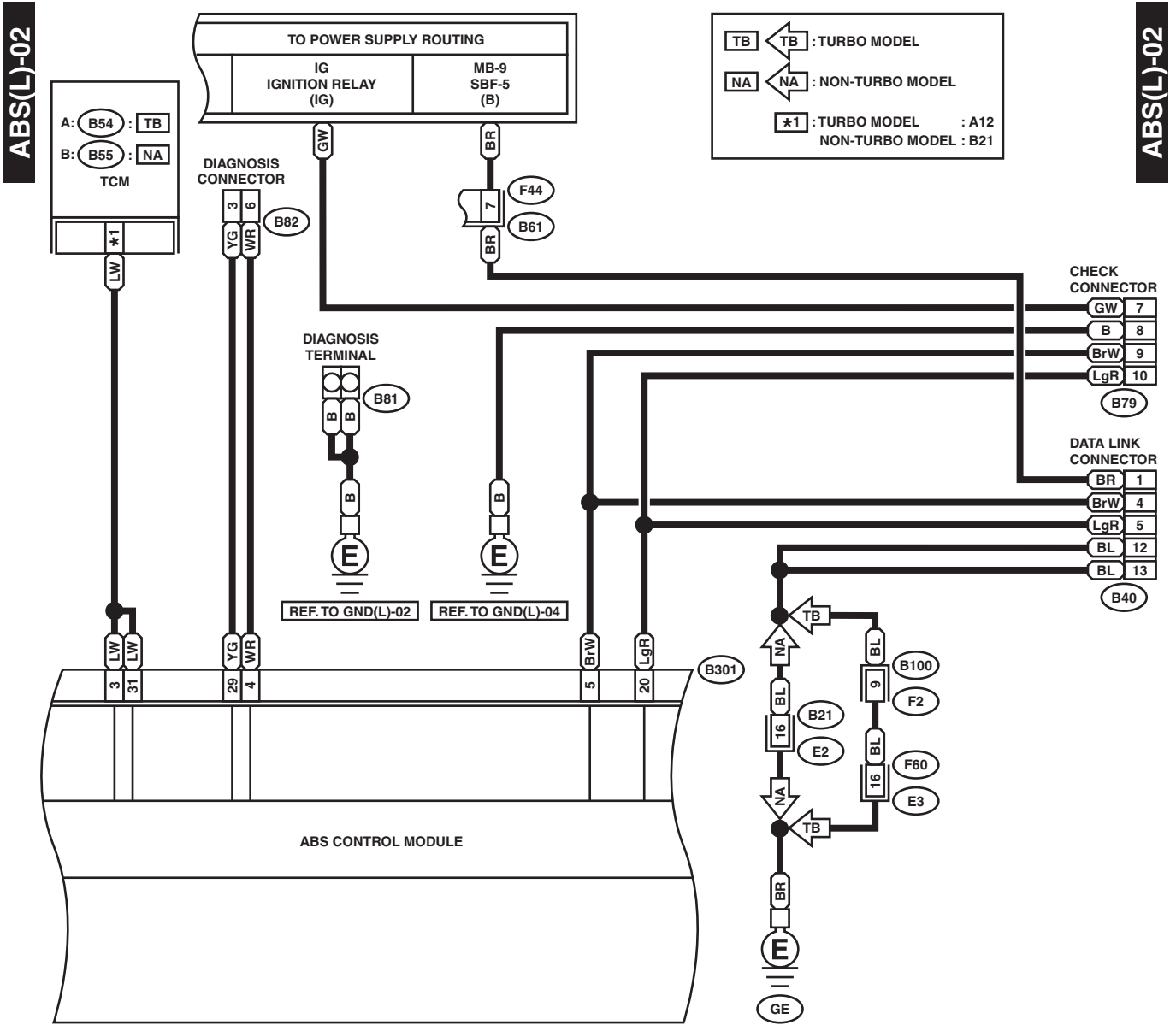

ABS(L)-02

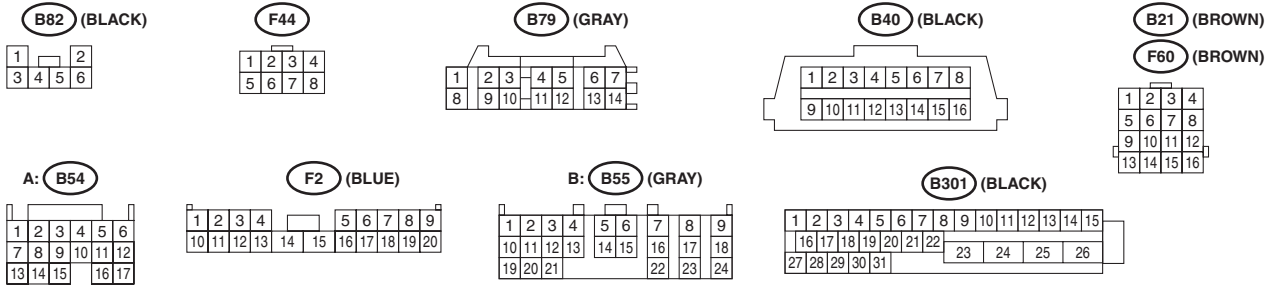

WI-03220

Anti-lock Brake System

WIRING SYSTEM

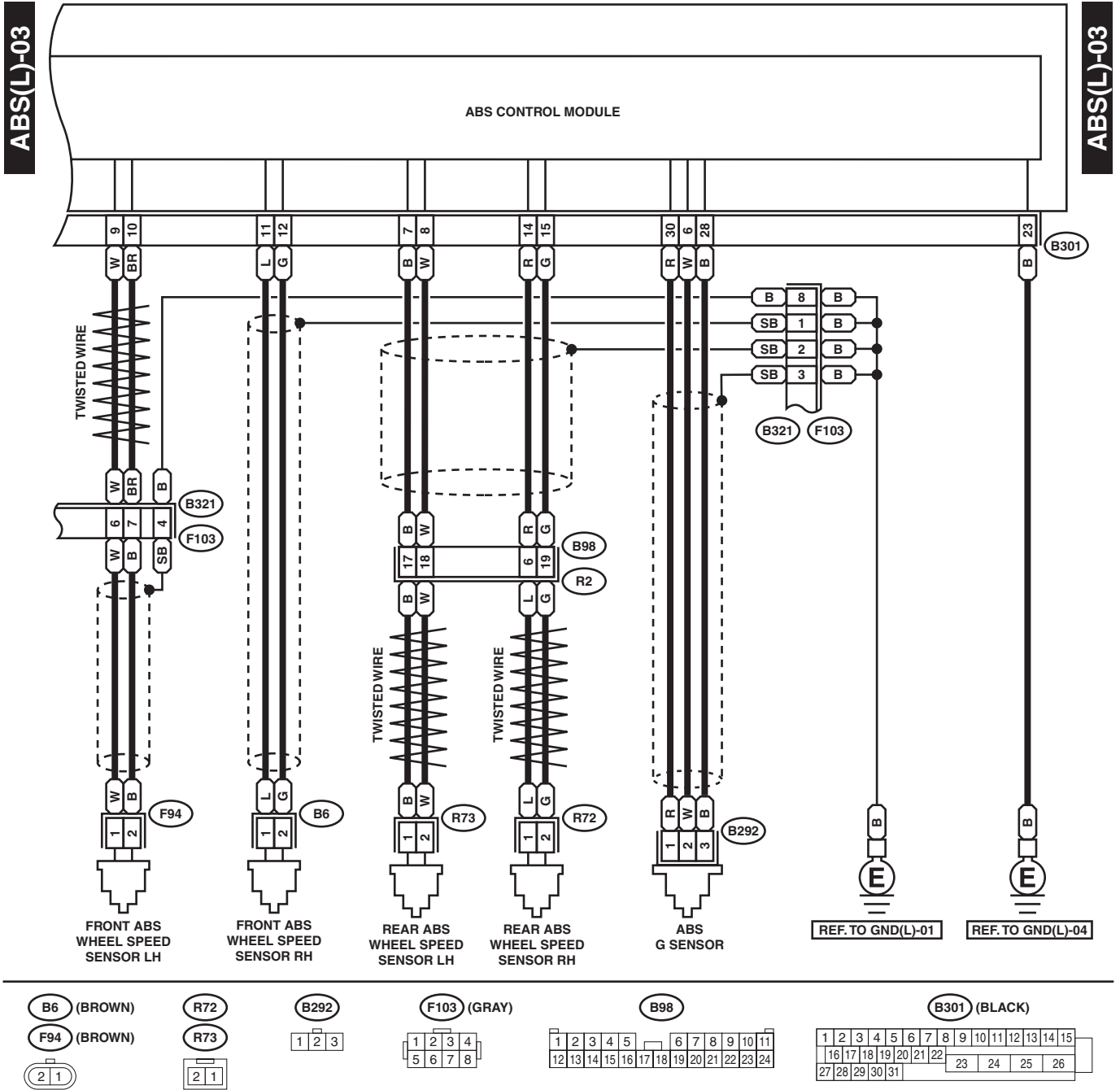

WI-03221

Anti-lock Brake System

WIRING SYSTEM

2. RHD MODEL

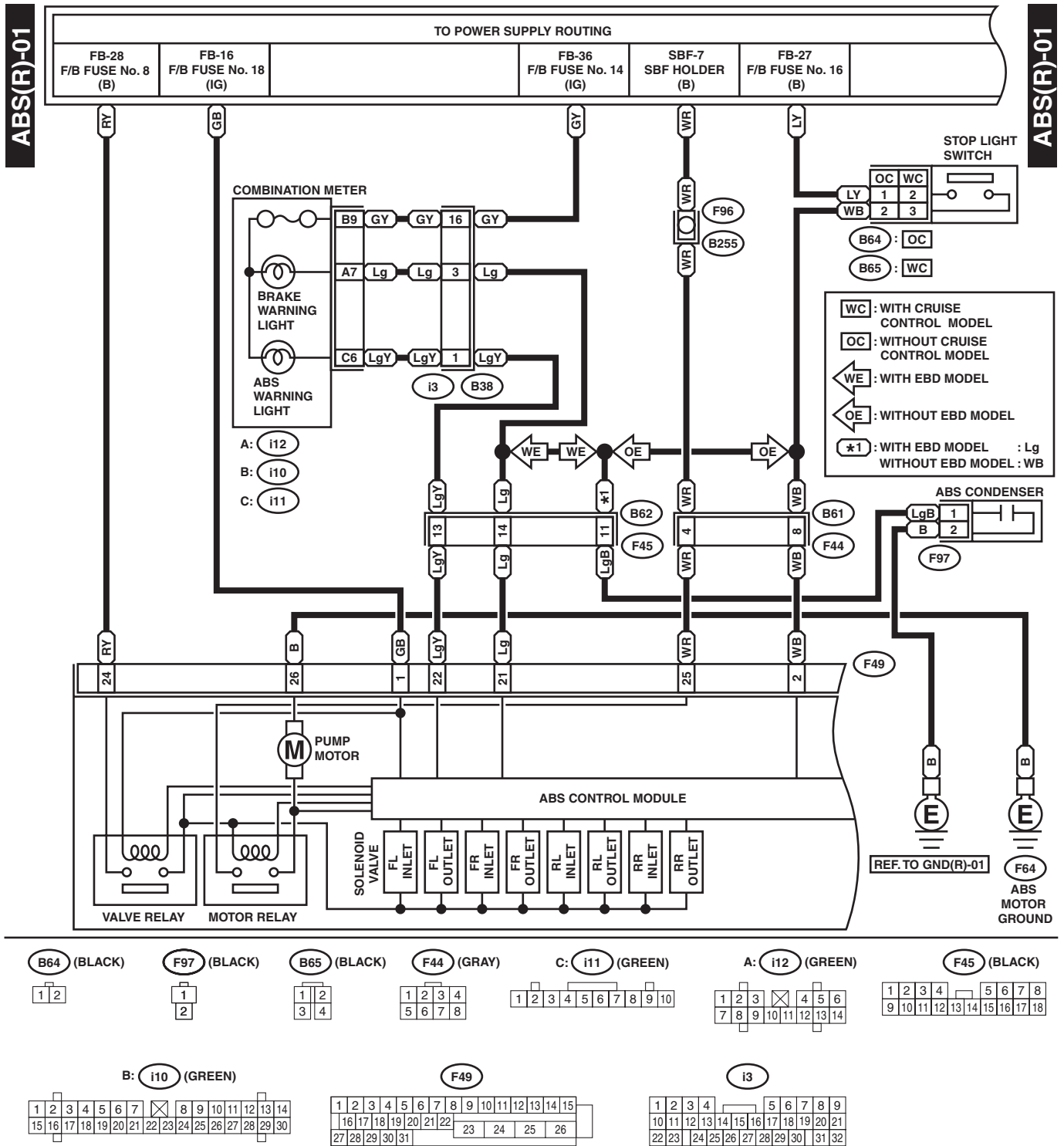

WI-03222

Anti-lock Brake System

WIRING SYSTEM

ABS(R)-02

ABS(R)-02

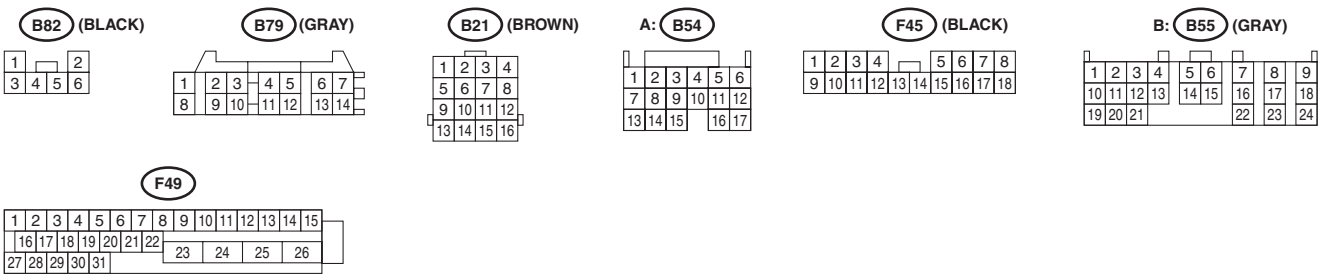
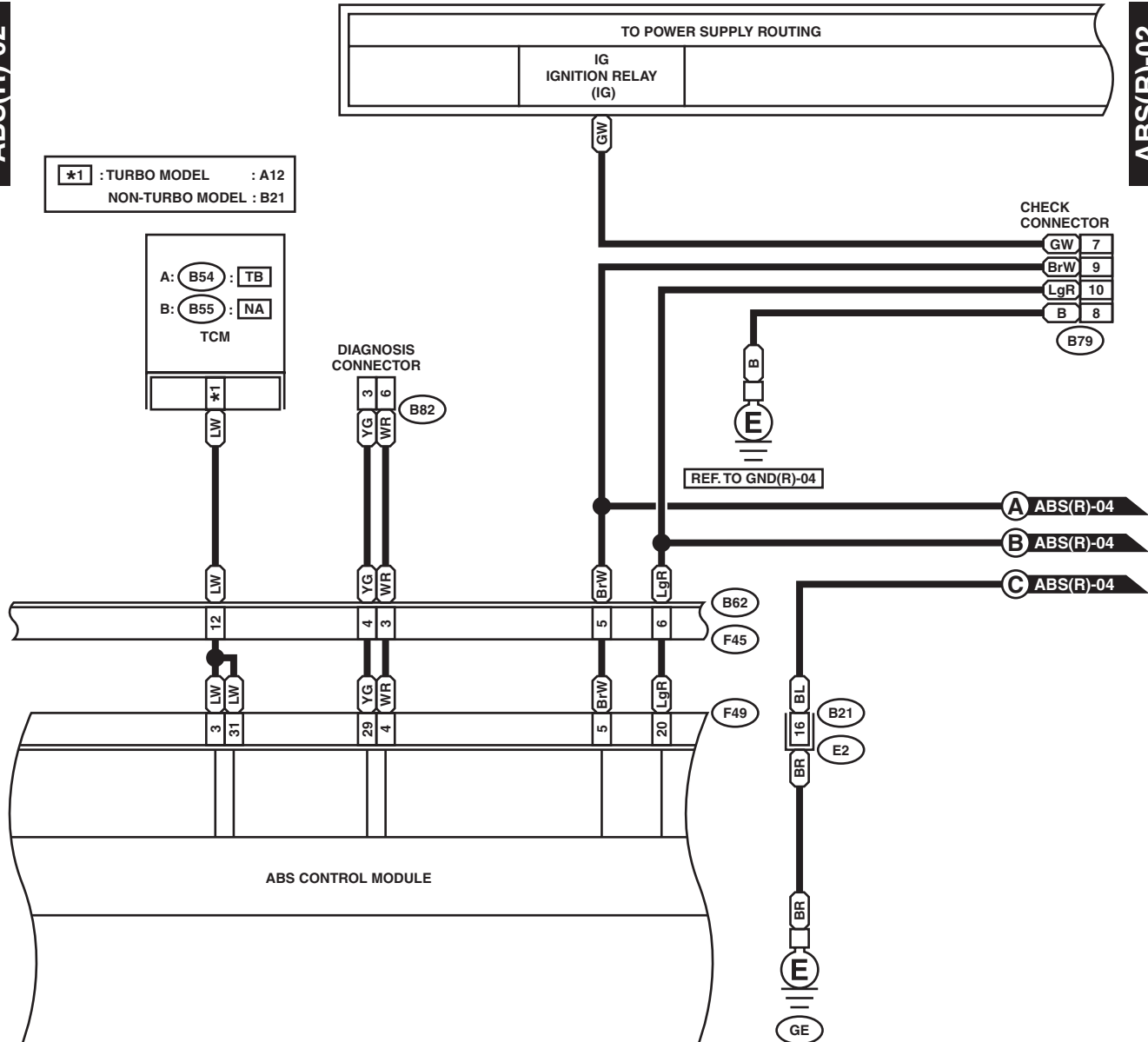

WI-03223

Anti-lock Brake System

WIRING SYSTEM

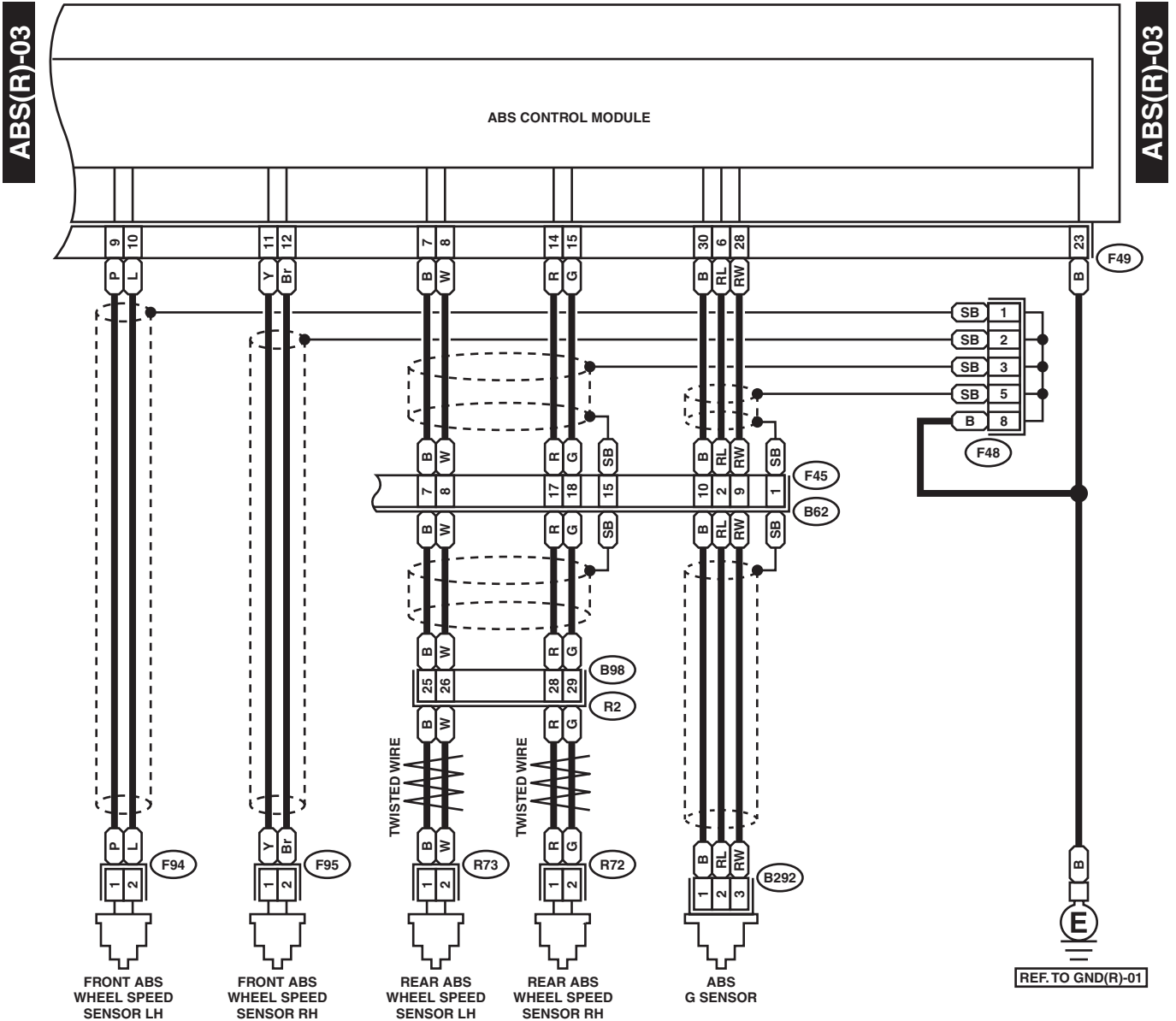

F94 (BROWN)

R72

B292

F48

F45 (BLACK)

F49

F95 (BROWN)

R73

1 2 3

1 2 3 4
5 6 7 8

1 2 3 4 5 6 7 8
9 10 11 12 13 14 15 16 17 18

1 2 3 4 5 6 7 8 9 10 11 12 13 14 15
16 17 18 19 20 21 22 23 24 25 26
27 28 29 30 31

B98

1 2 3 4 5 6 7 8 9
10 11 12 13 14 15 16 17 18 19 20 21
22 23 24 25 26 27 28 29 30 31 32

WI-03224

Anti-lock Brake System

WIRING SYSTEM

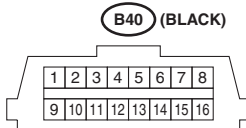
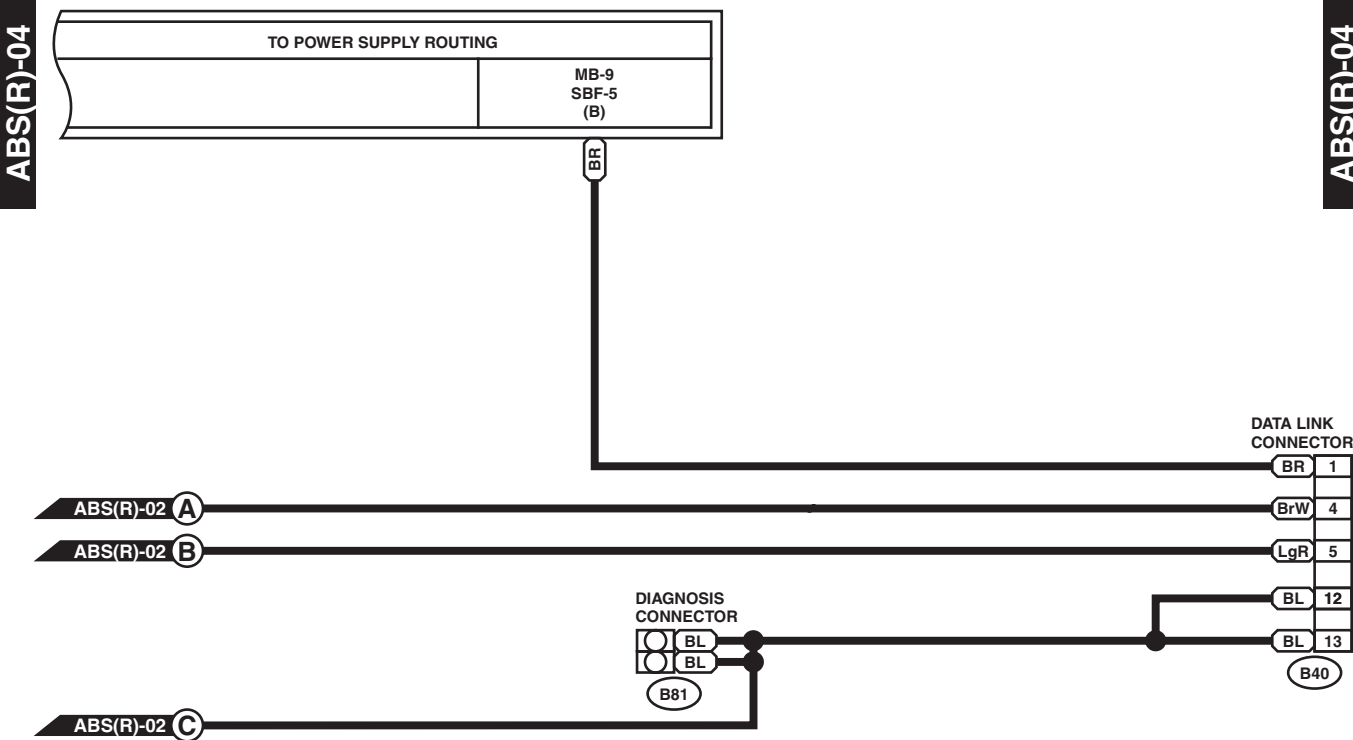

WI-03225

8. AT Control System

A: WIRING DIAGRAM

1. LHD NON-TURBO MODEL

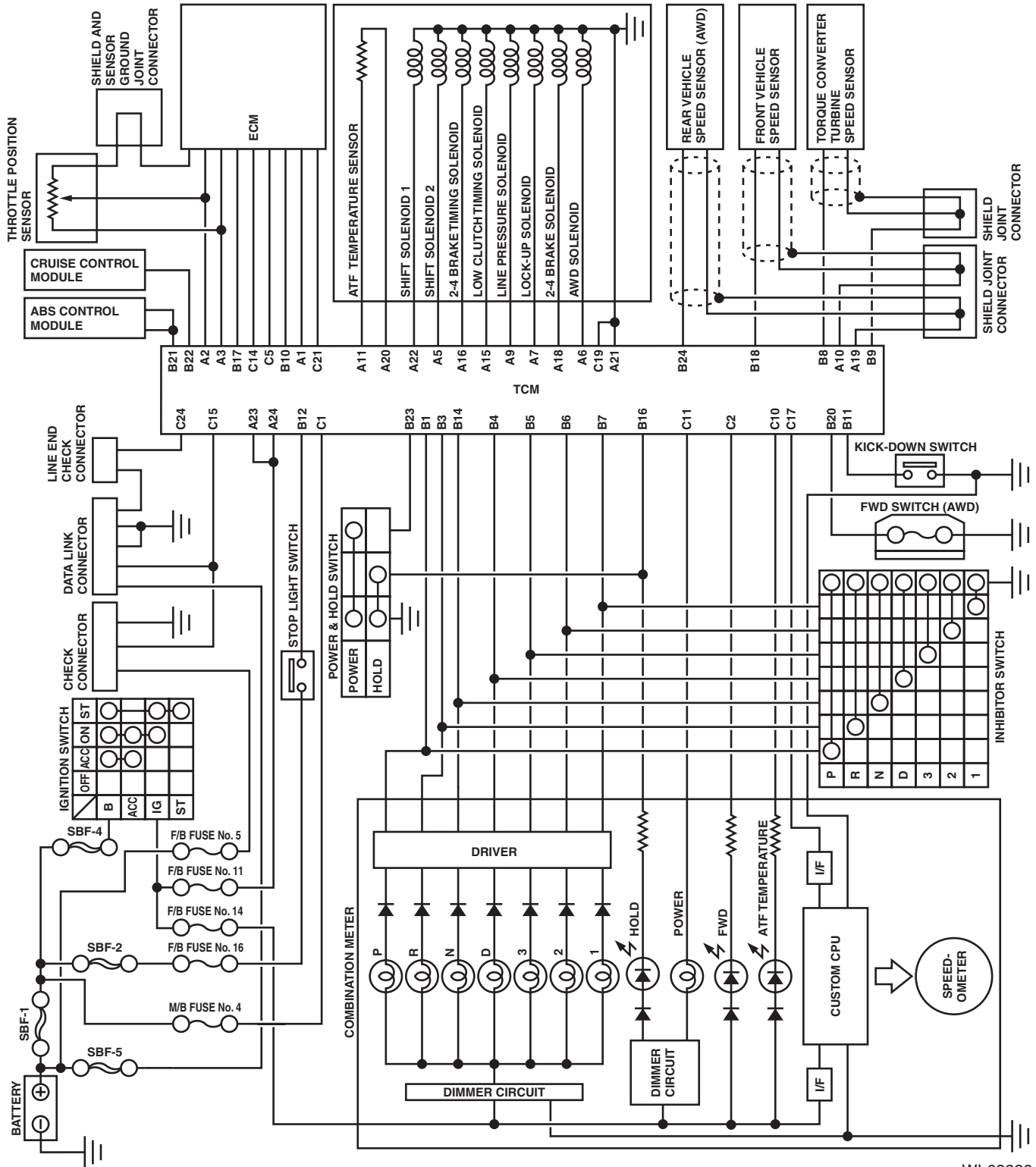

WI-03226

AT Control System

WIRING SYSTEM

AT(LNA)-01

AT(LNA)-01

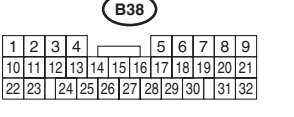
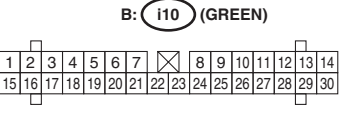
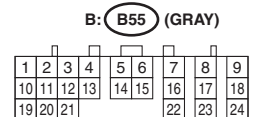
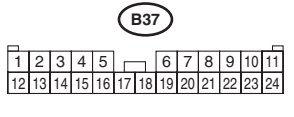
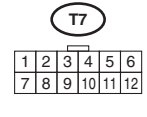
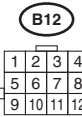
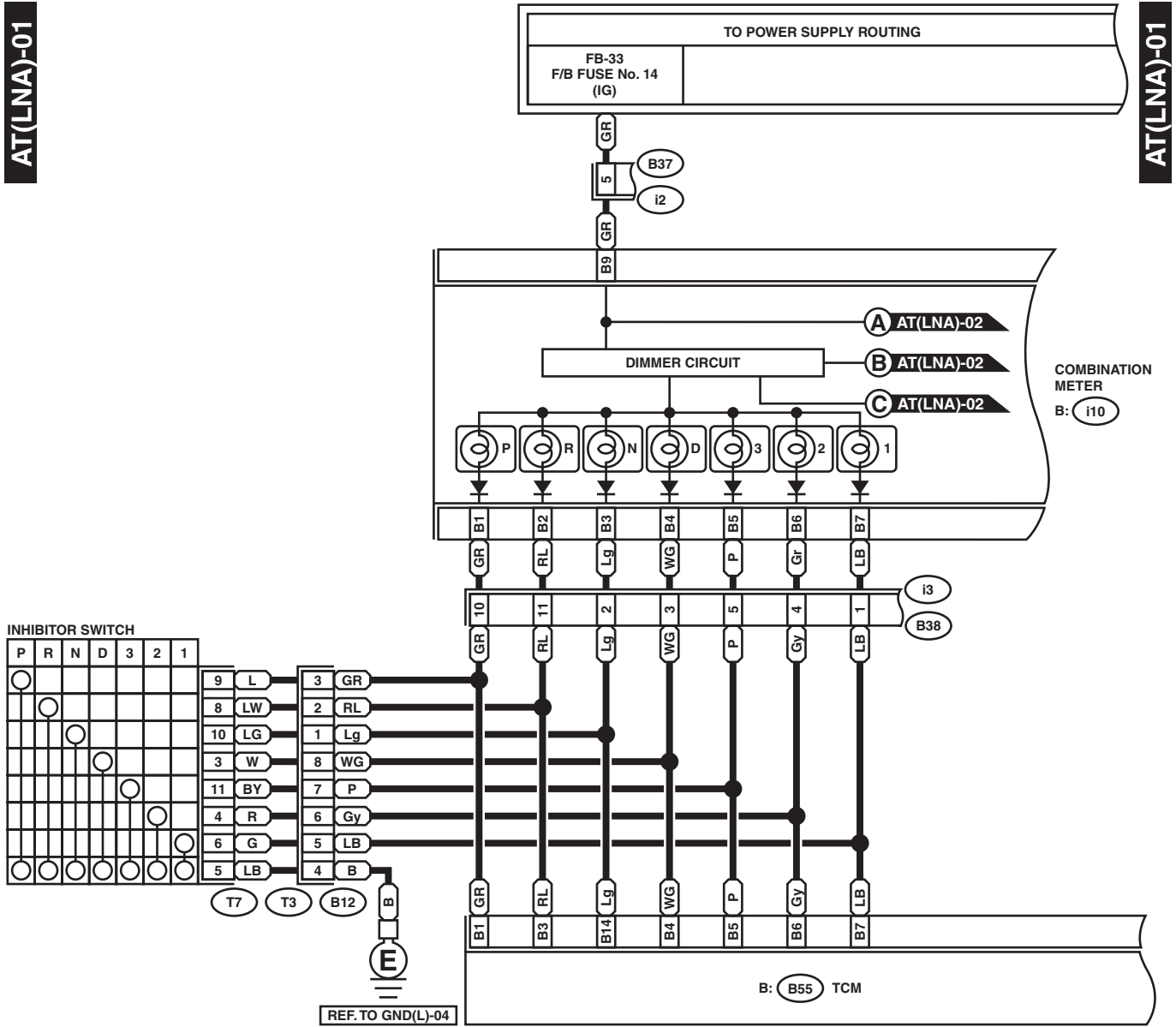

WI-03227

AT Control System

WIRING SYSTEM

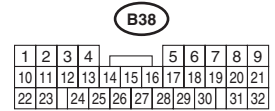
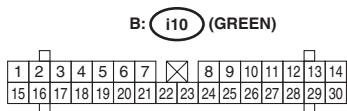
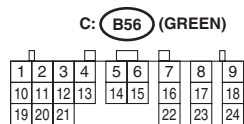
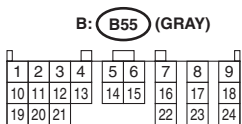
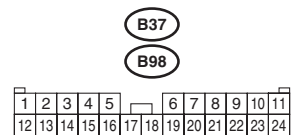
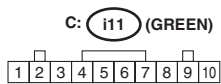
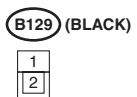
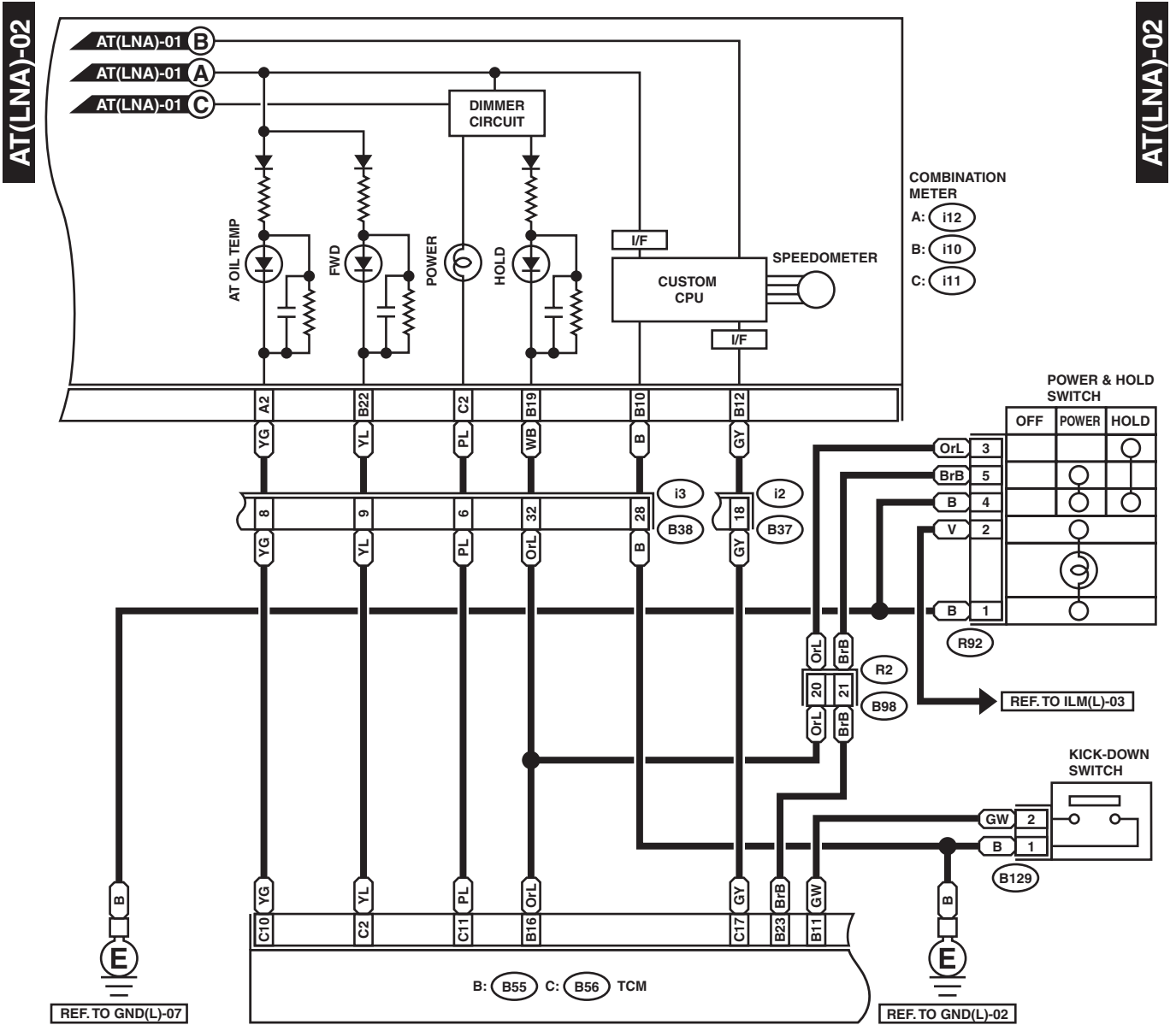

WI-03228

AT Control System

WIRING SYSTEM

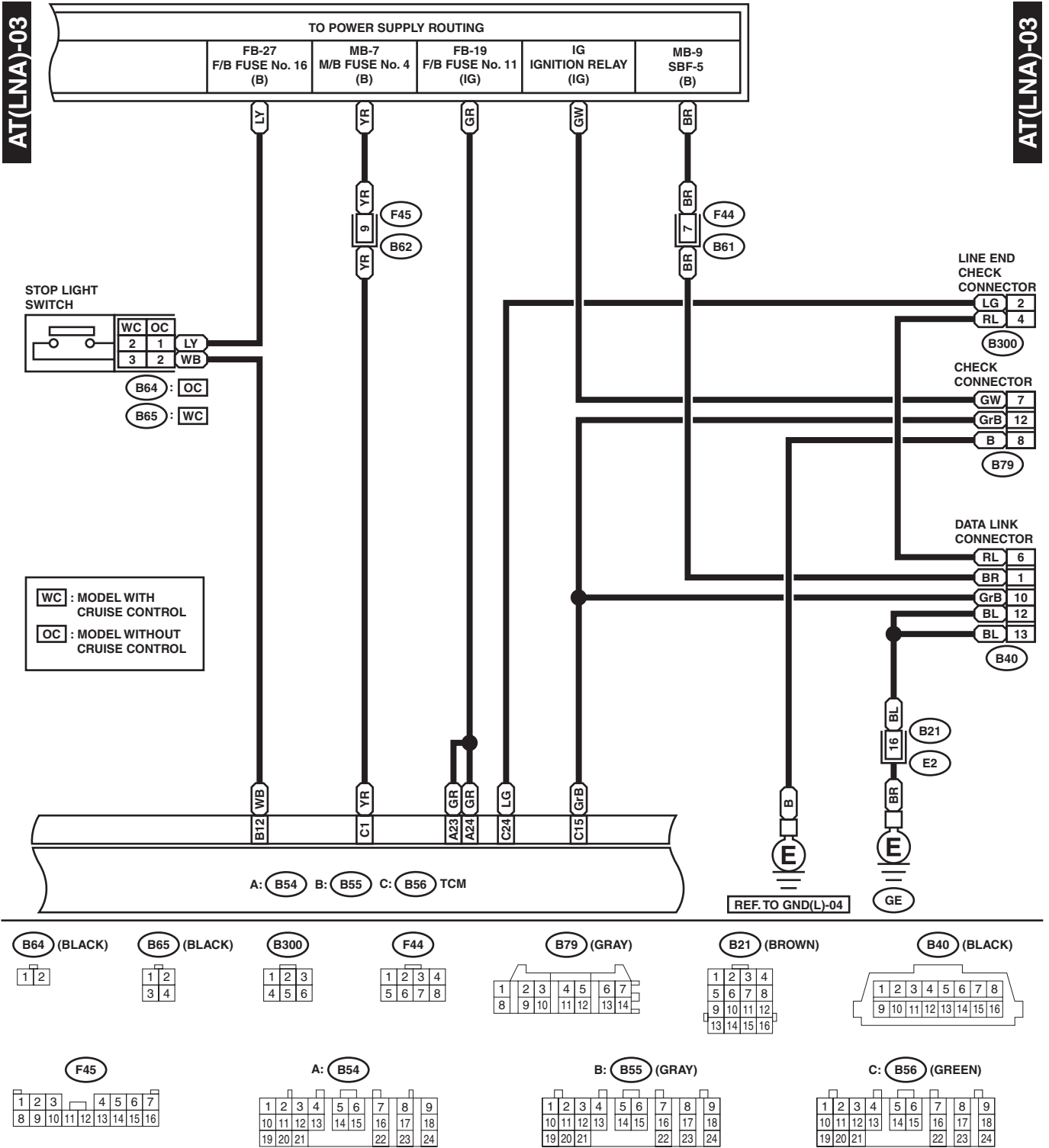

WI-03229

AT Control System

WIRING SYSTEM

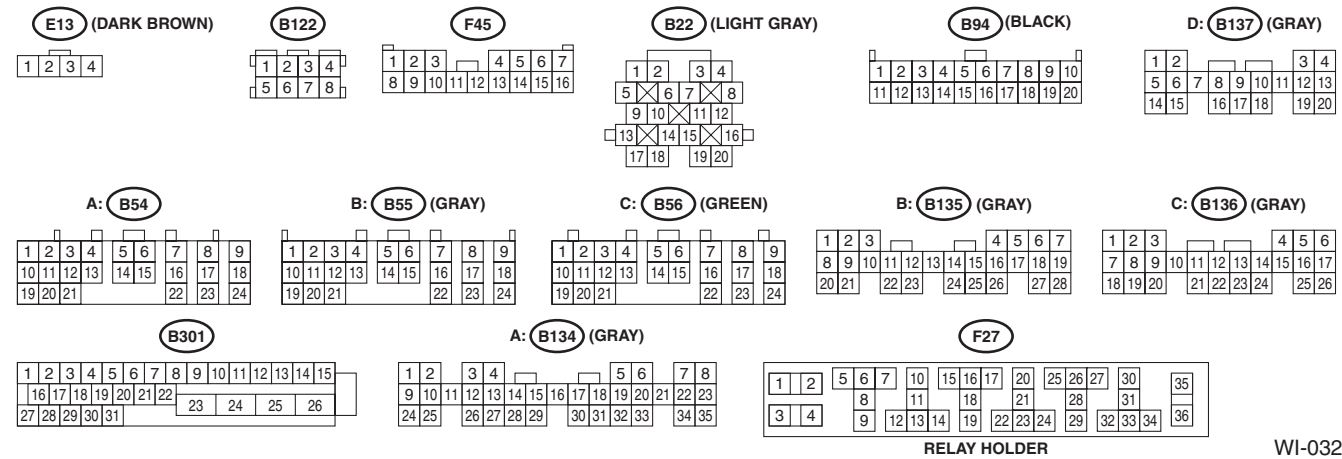
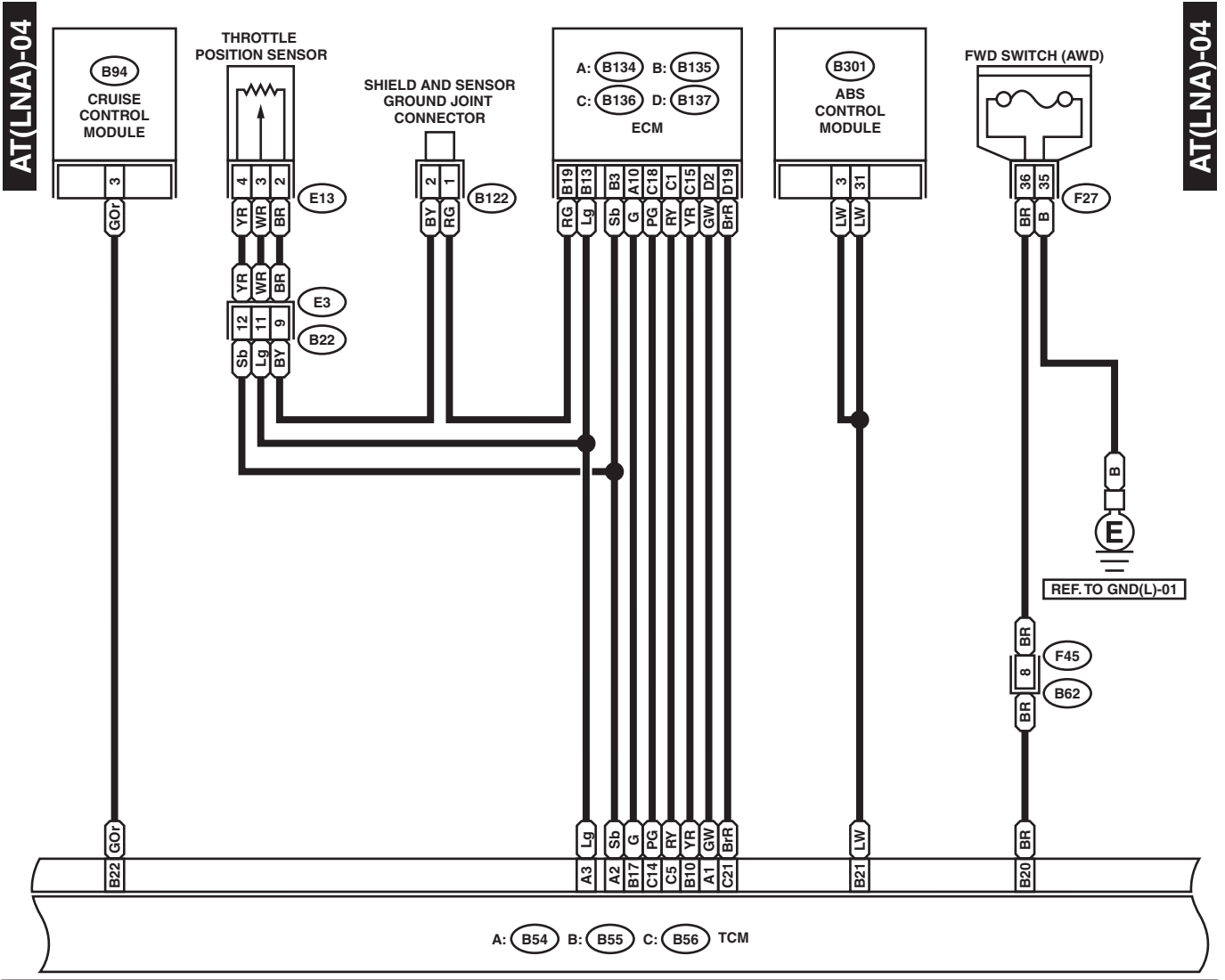

WI-03230

AT Control System

WIRING SYSTEM

AT(LNA)-05

AT(LNA)-05

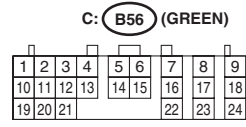
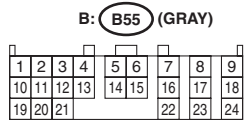
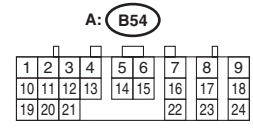
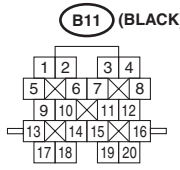
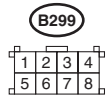
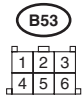
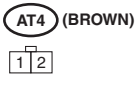
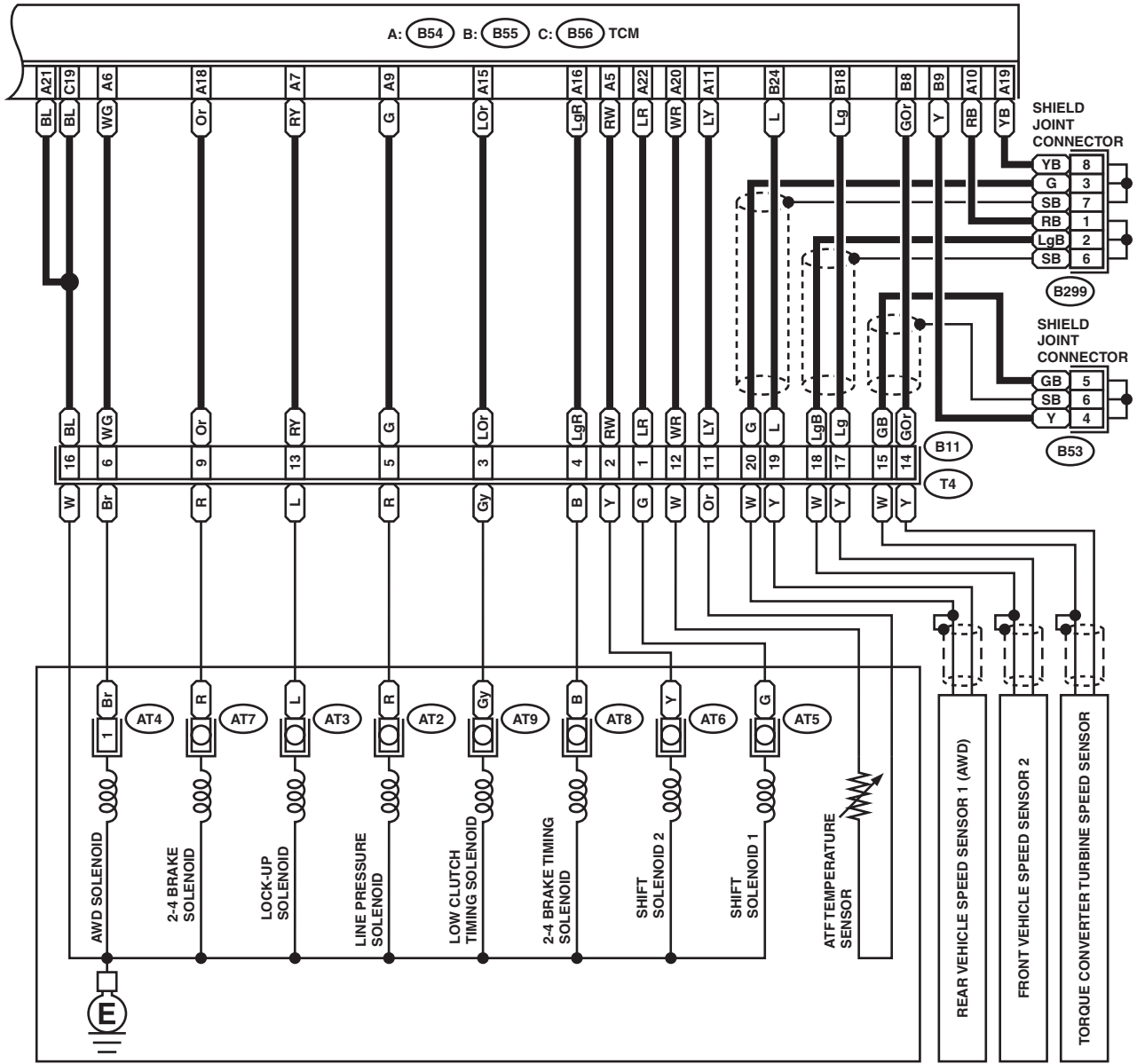

WI-03231

2. LHD TURBO MODEL

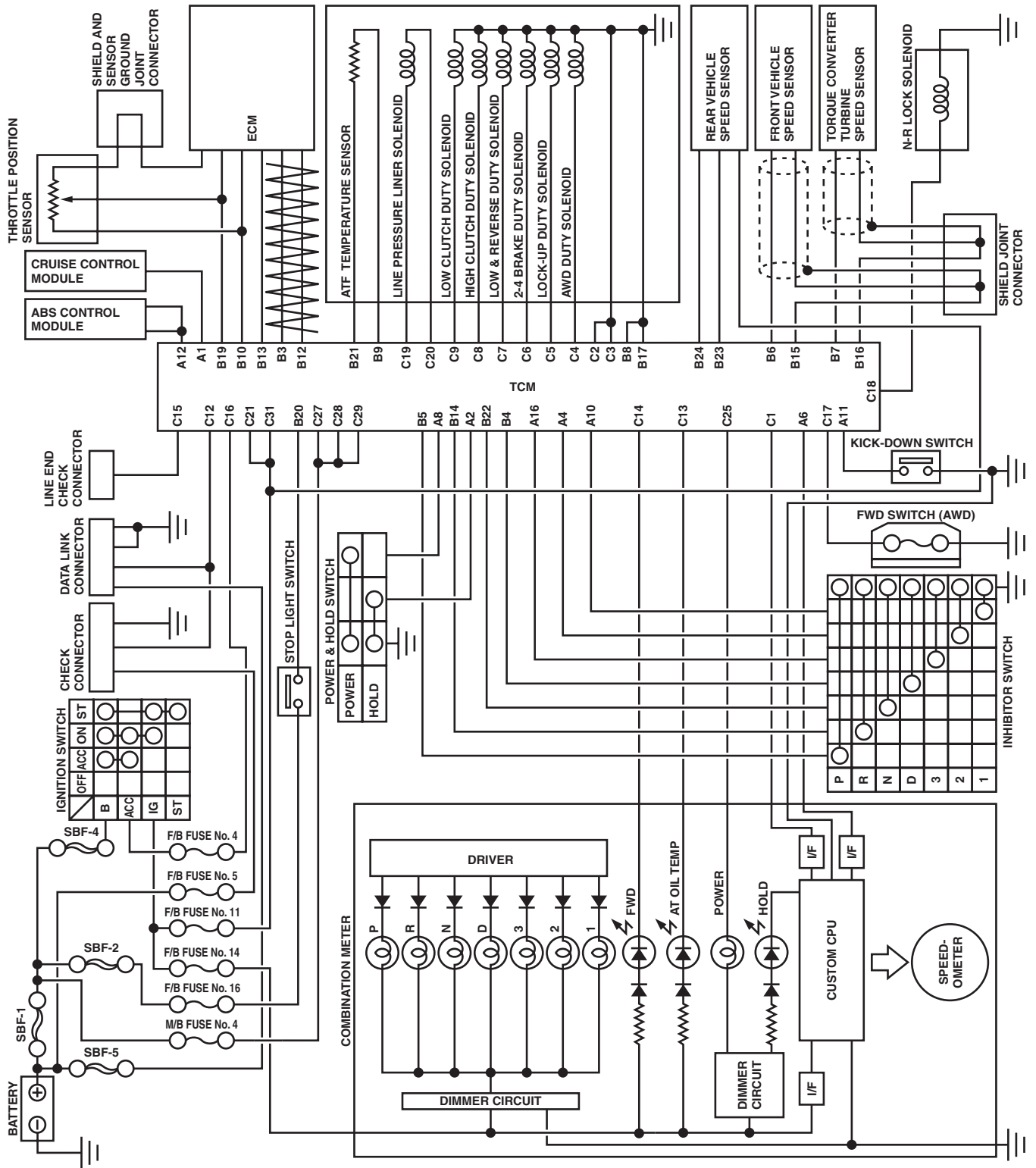

WI-03232

AT Control System

WIRING SYSTEM

AT-(LTB)-01

AT-(LTB)-01

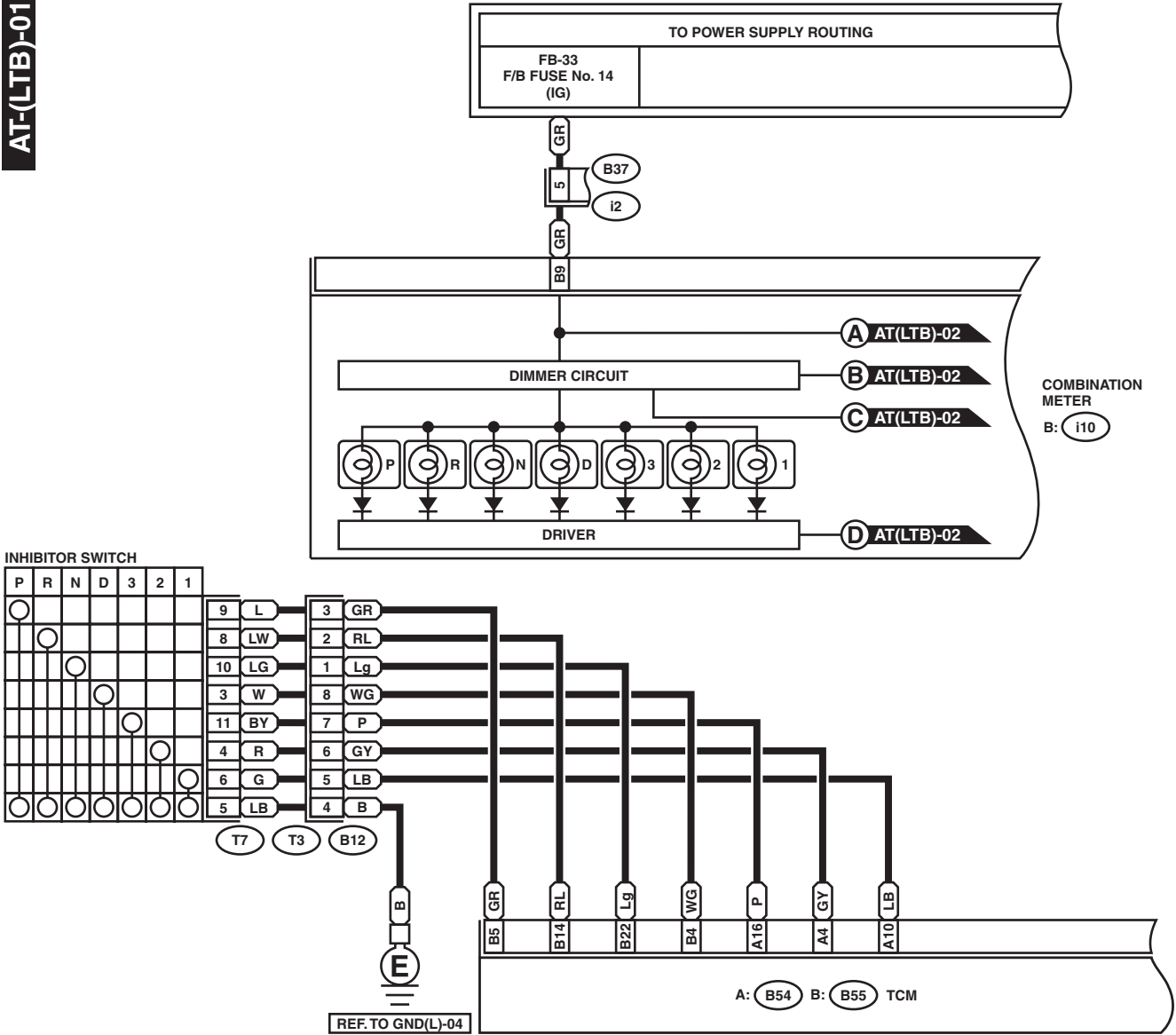

INHIBITOR SWITCH

P	R	N	D	3	2	1
<input type="checkbox"/>	<input type="checkbox"/>	<input type="checkbox"/>	<input type="checkbox"/>	<input type="checkbox"/>	<input type="checkbox"/>	<input type="checkbox"/>
<input type="checkbox"/>	<input type="checkbox"/>	<input type="checkbox"/>	<input type="checkbox"/>	<input type="checkbox"/>	<input type="checkbox"/>	<input type="checkbox"/>
<input type="checkbox"/>	<input type="checkbox"/>	<input type="checkbox"/>	<input type="checkbox"/>	<input type="checkbox"/>	<input type="checkbox"/>	<input type="checkbox"/>
<input type="checkbox"/>	<input type="checkbox"/>	<input type="checkbox"/>	<input type="checkbox"/>	<input type="checkbox"/>	<input type="checkbox"/>	<input type="checkbox"/>
<input type="checkbox"/>	<input type="checkbox"/>	<input type="checkbox"/>	<input type="checkbox"/>	<input type="checkbox"/>	<input type="checkbox"/>	<input type="checkbox"/>
<input type="checkbox"/>	<input type="checkbox"/>	<input type="checkbox"/>	<input type="checkbox"/>	<input type="checkbox"/>	<input type="checkbox"/>	<input type="checkbox"/>
<input type="checkbox"/>	<input type="checkbox"/>	<input type="checkbox"/>	<input type="checkbox"/>	<input type="checkbox"/>	<input type="checkbox"/>	<input type="checkbox"/>
<input type="checkbox"/>	<input type="checkbox"/>	<input type="checkbox"/>	<input type="checkbox"/>	<input type="checkbox"/>	<input type="checkbox"/>	<input type="checkbox"/>
<input type="checkbox"/>	<input type="checkbox"/>	<input type="checkbox"/>	<input type="checkbox"/>	<input type="checkbox"/>	<input type="checkbox"/>	<input type="checkbox"/>

9	L	3	GR
8	LW	2	RL
10	LG	1	Lg
3	W	8	WG
11	BY	7	P
4	R	6	GY
6	G	5	LB
5	LB	4	B

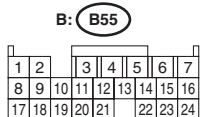
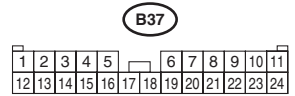
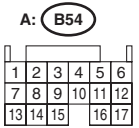
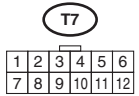
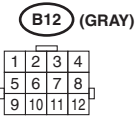

B: i10 (GREEN)

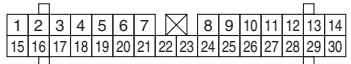

WI-03233

AT Control System

WIRING SYSTEM

AT(LTB)-02

AT(LTB)-02

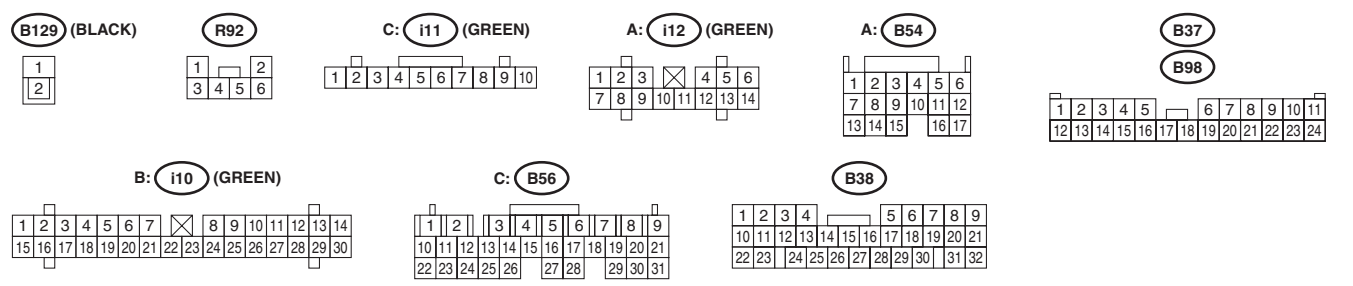
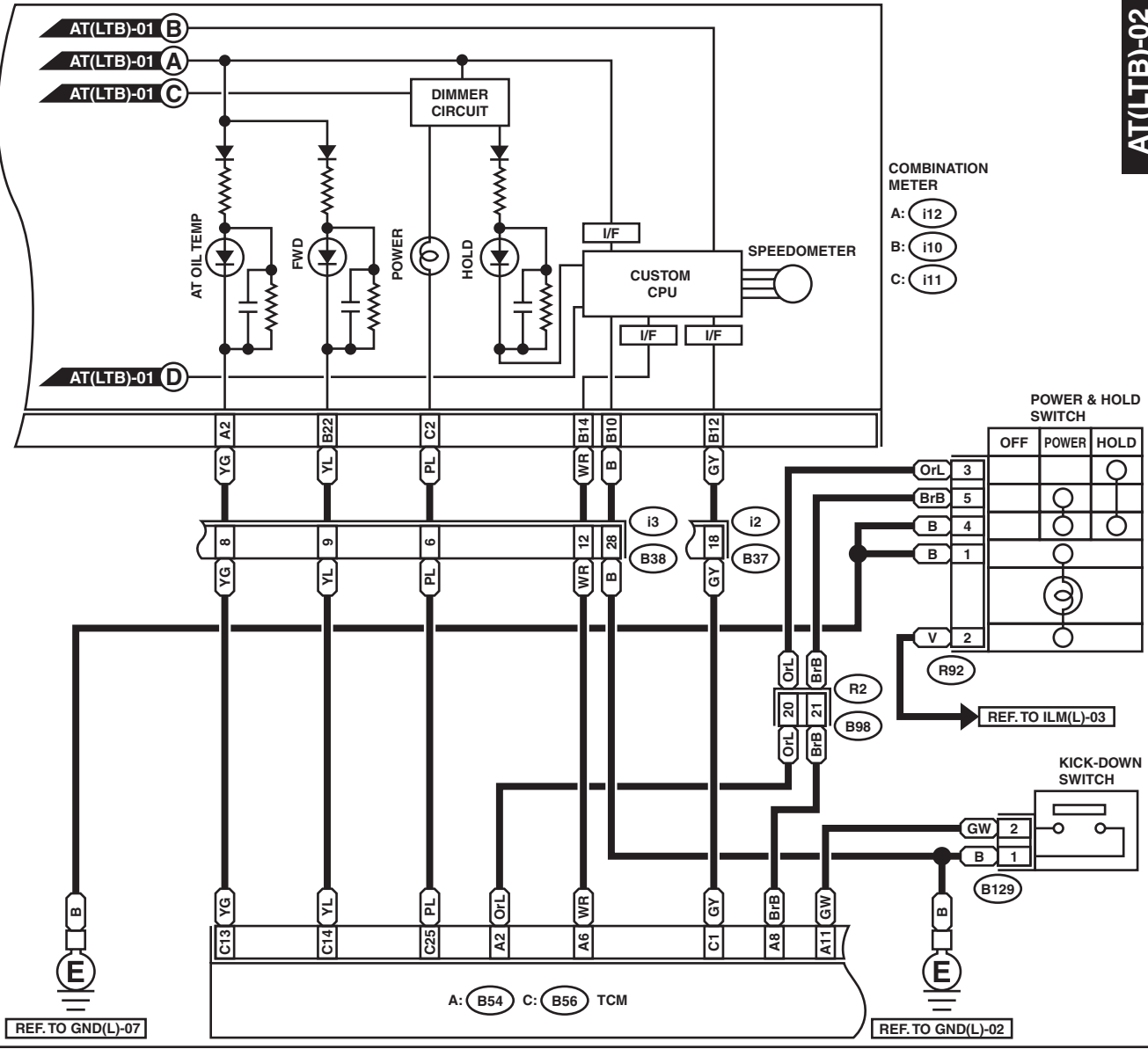

WI-03234

AT Control System

WIRING SYSTEM

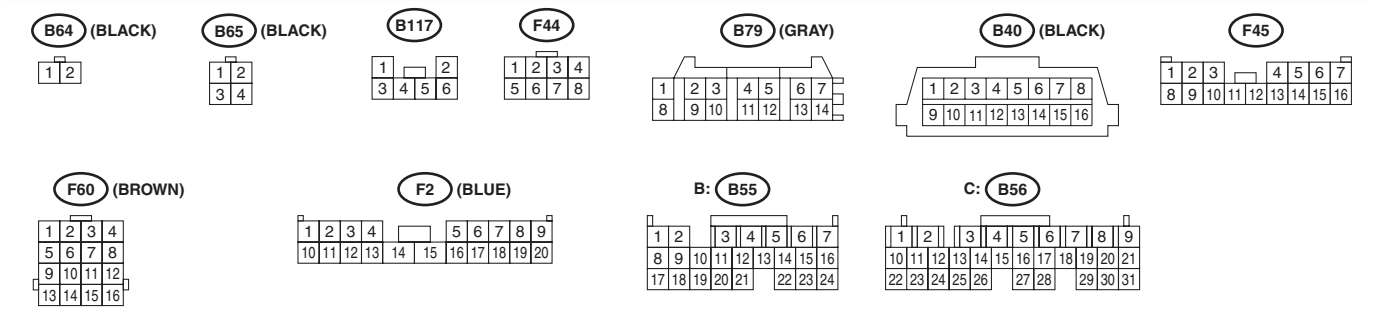
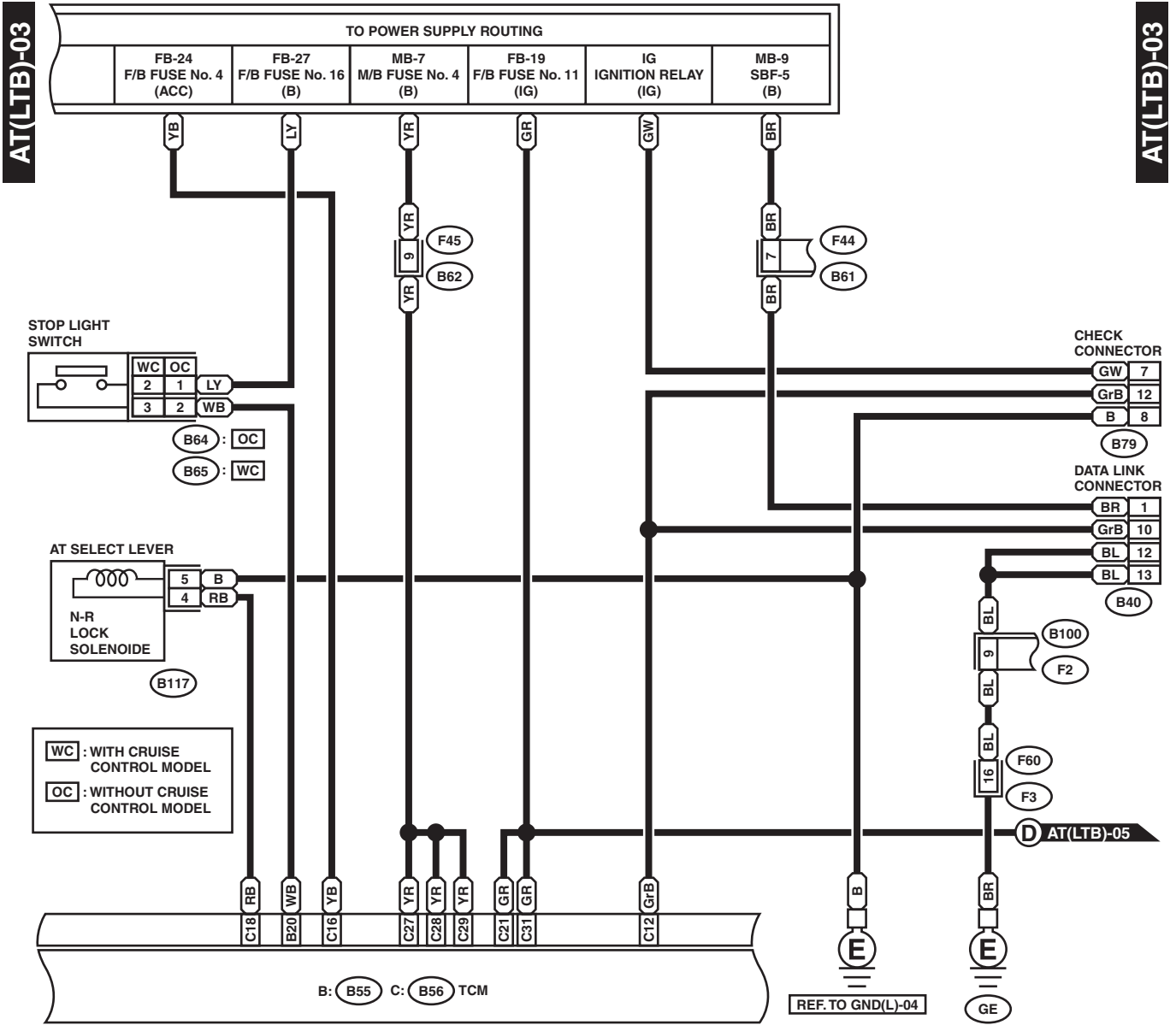

WI-03235

AT Control System

WIRING SYSTEM

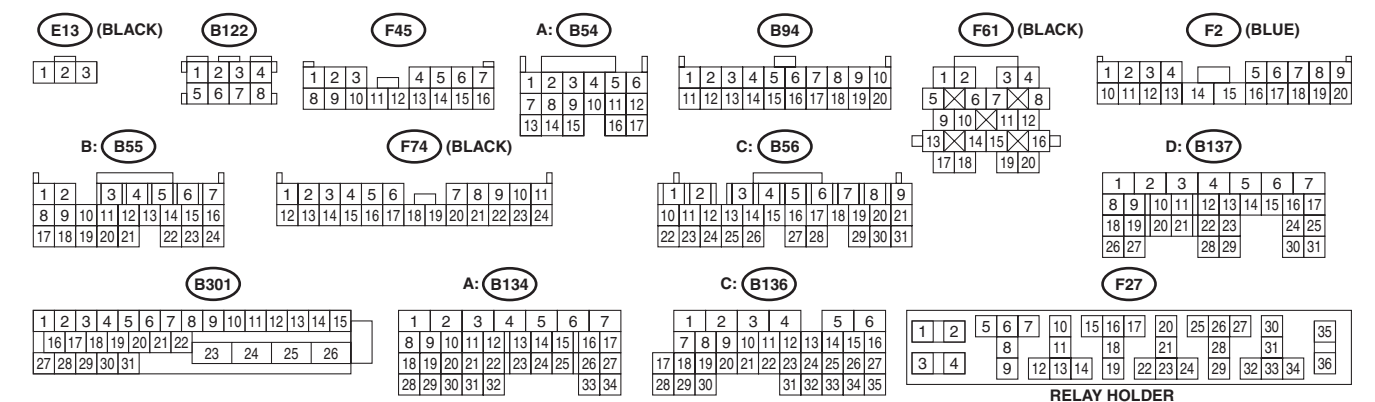
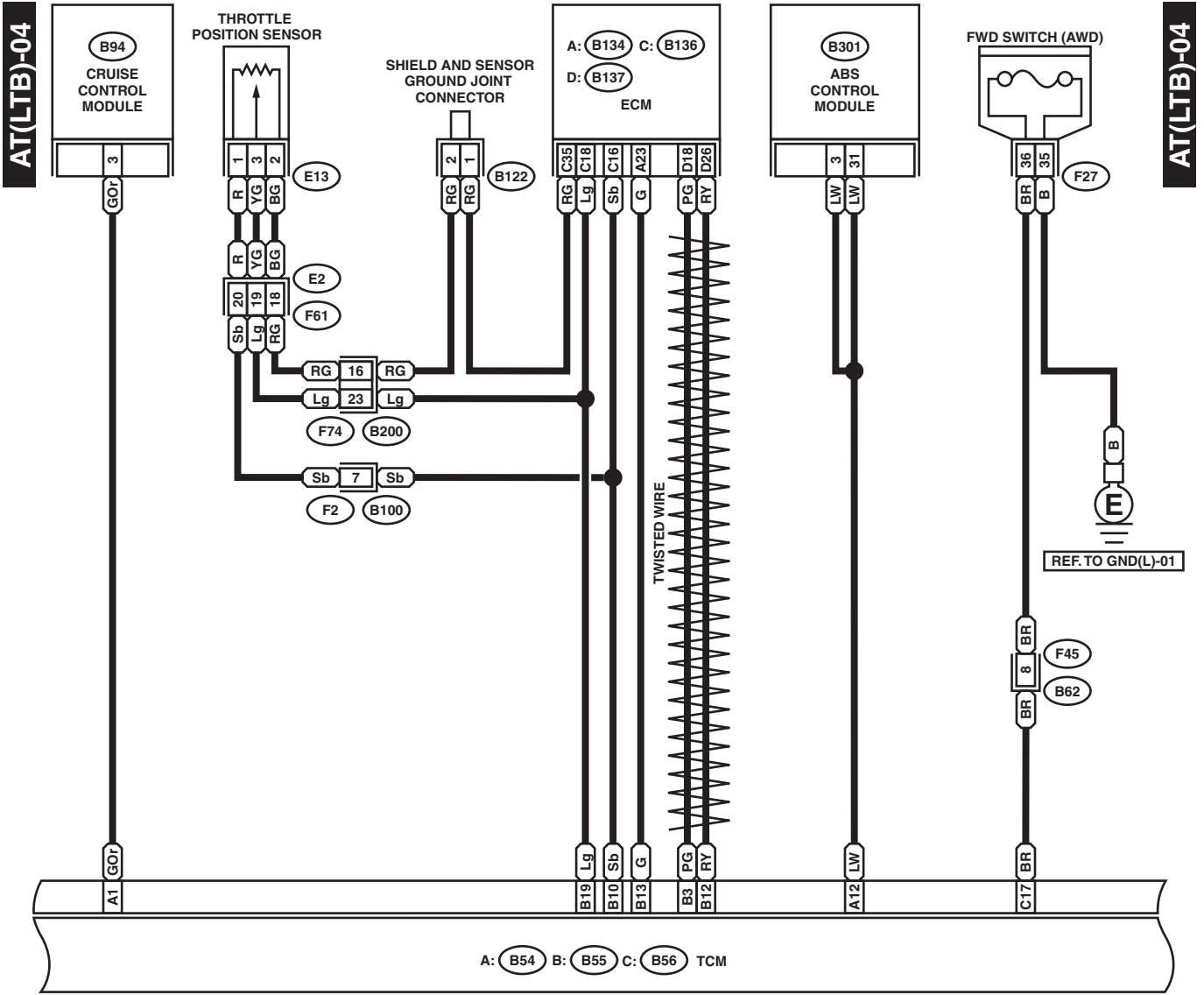

WI-03236

AT Control System

WIRING SYSTEM

AT(LTB)-05

AT(LTB)-05

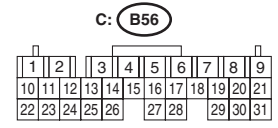
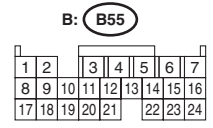
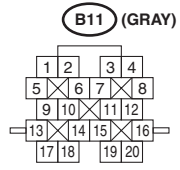
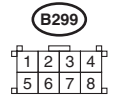
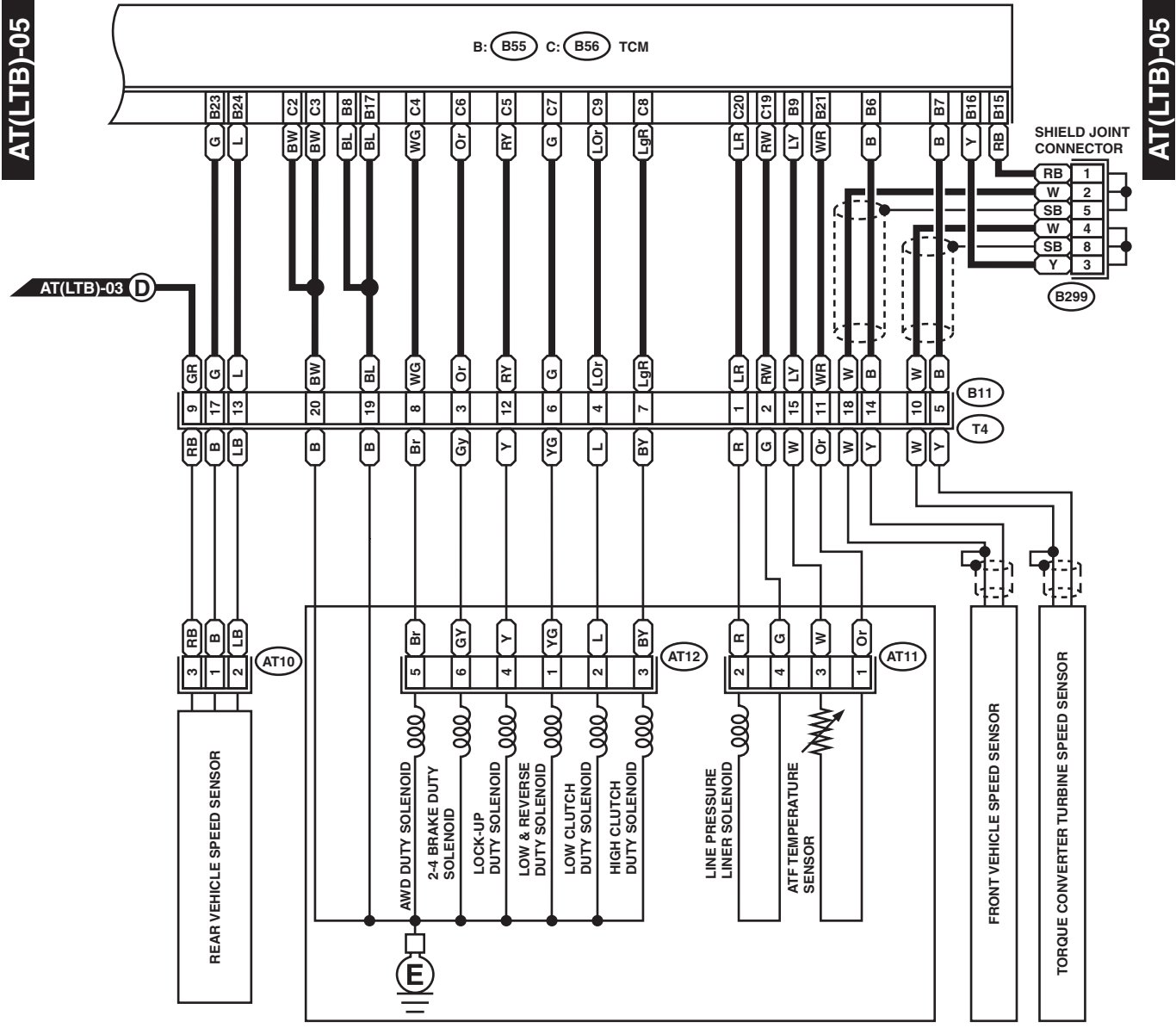

WI-03237

3. RHD NON-TURBO MODEL

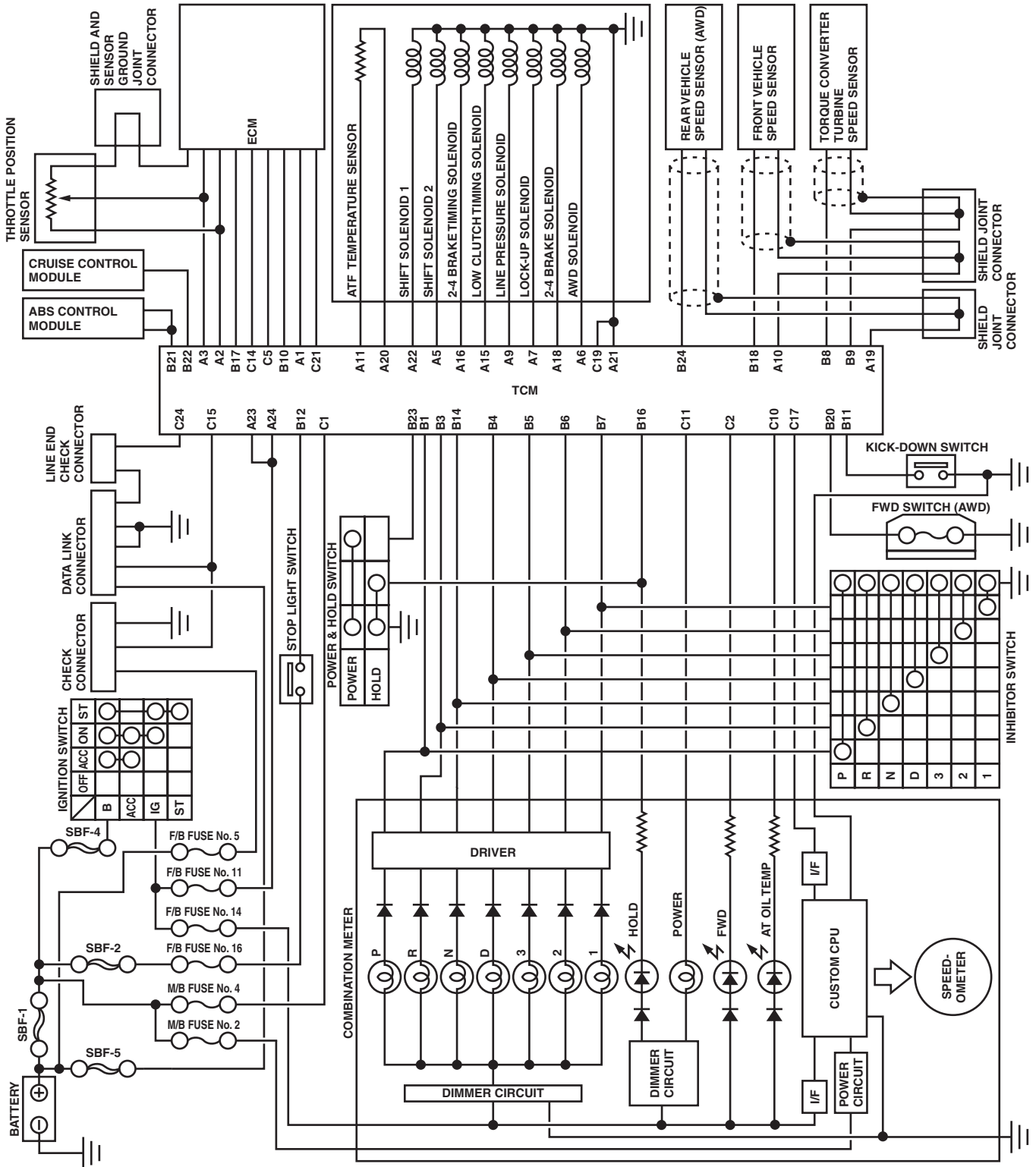

WI-03238

AT Control System

WIRING SYSTEM

AT(RNA)-01

AT(RNA)-01

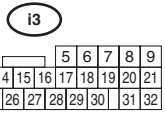
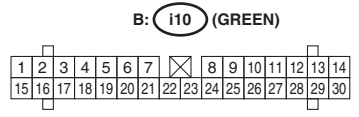
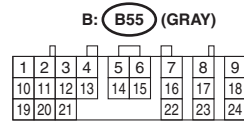
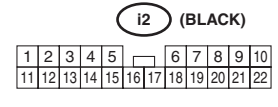
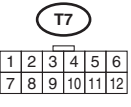
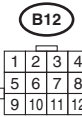
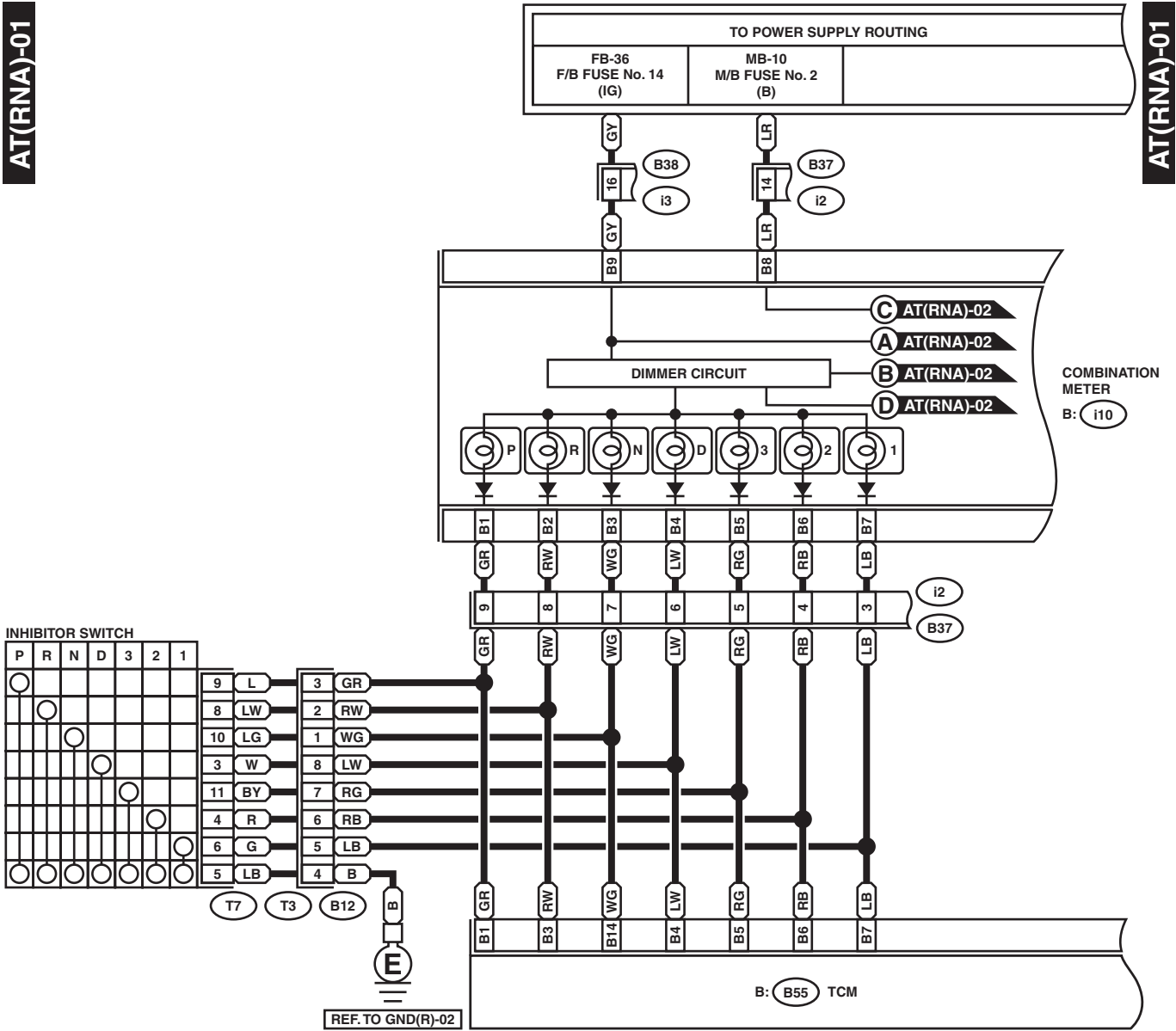

AT Control System

WIRING SYSTEM

AT(RNA)-02

AT(RNA)-02

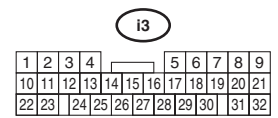
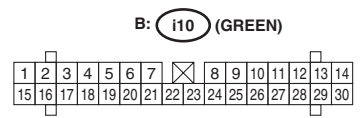
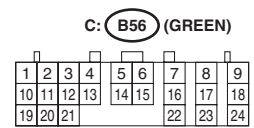
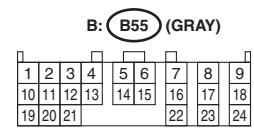
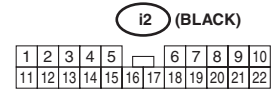
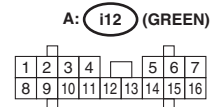
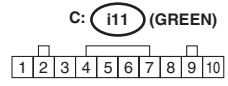
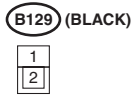
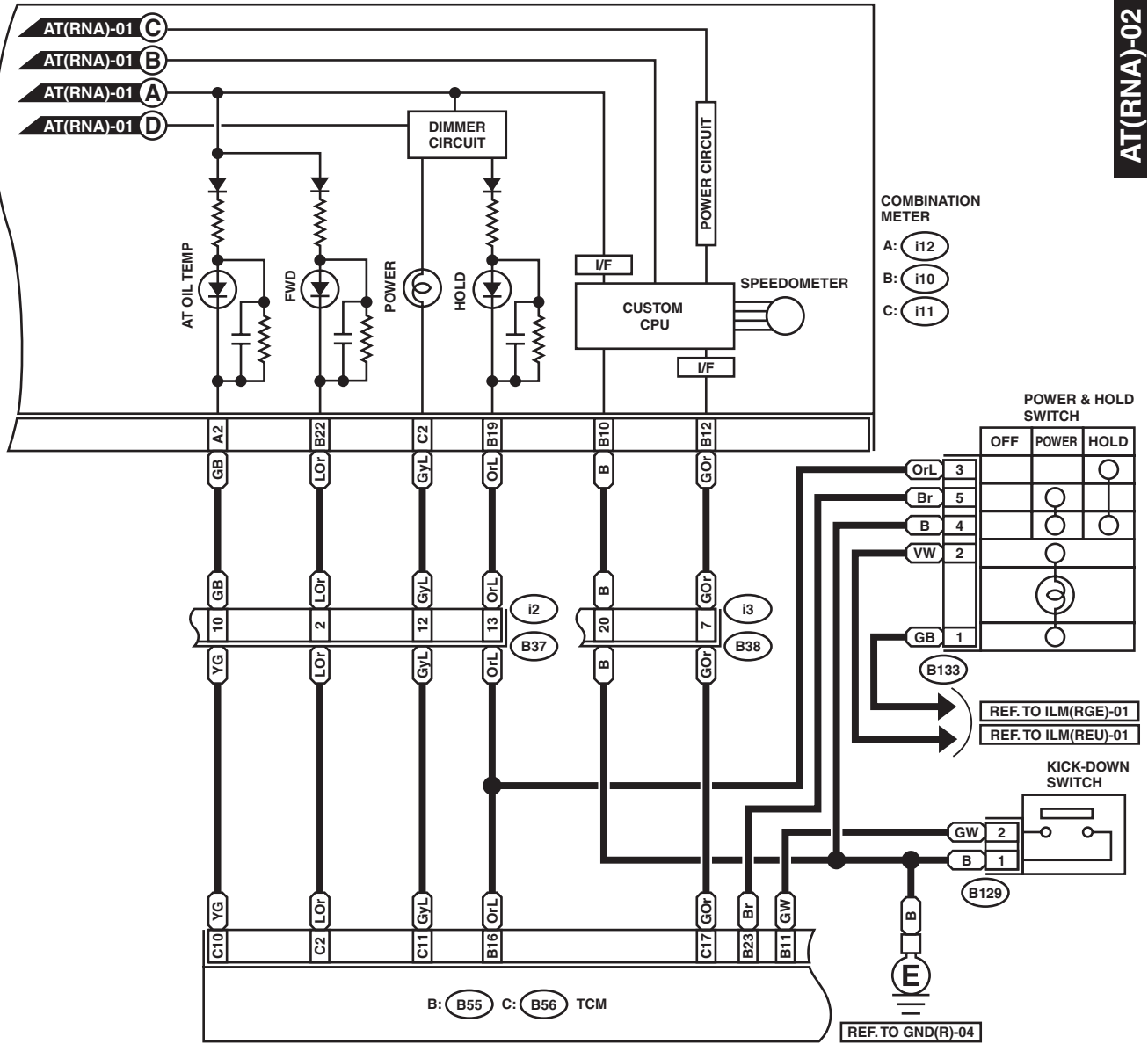

WI-03240

AT Control System

WIRING SYSTEM

AT(RNA)-03

AT(RNA)-03

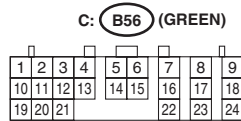
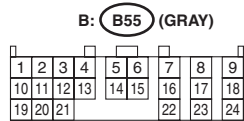
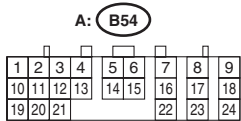
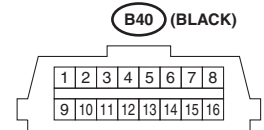
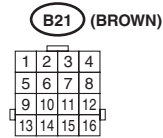
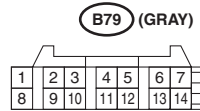
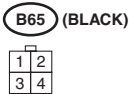
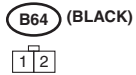
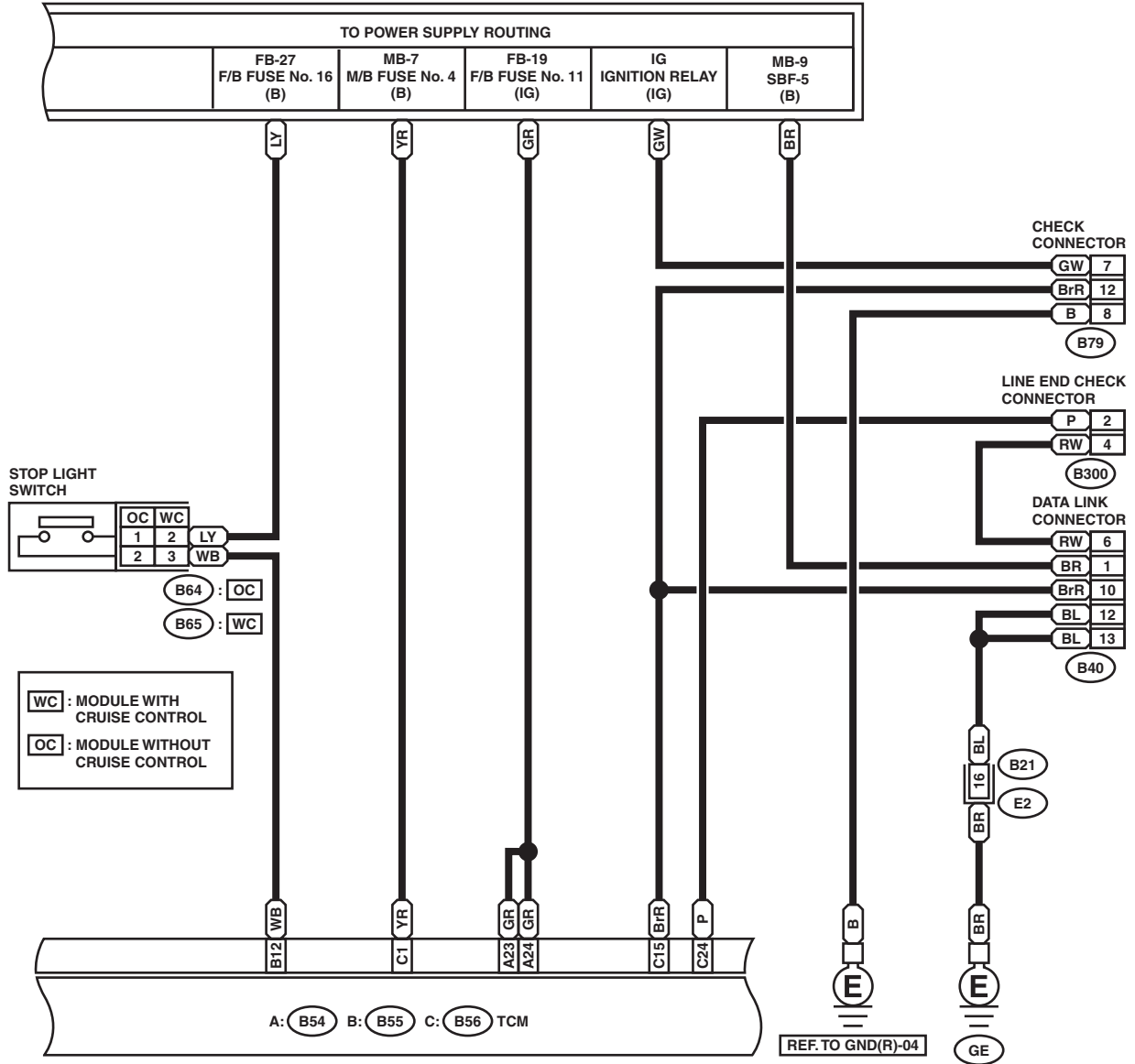

WI-03241

AT Control System

WIRING SYSTEM

AT(RNA)-04

AT(RNA)-04

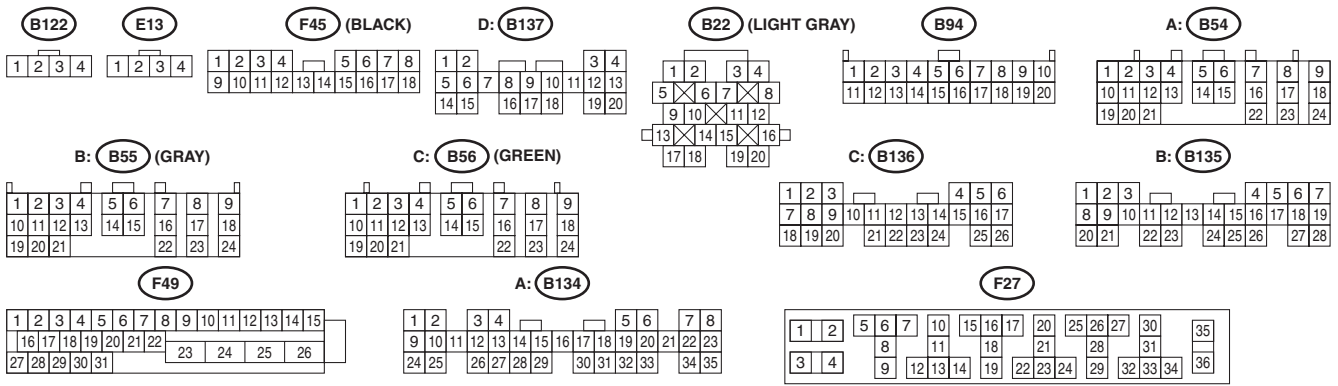
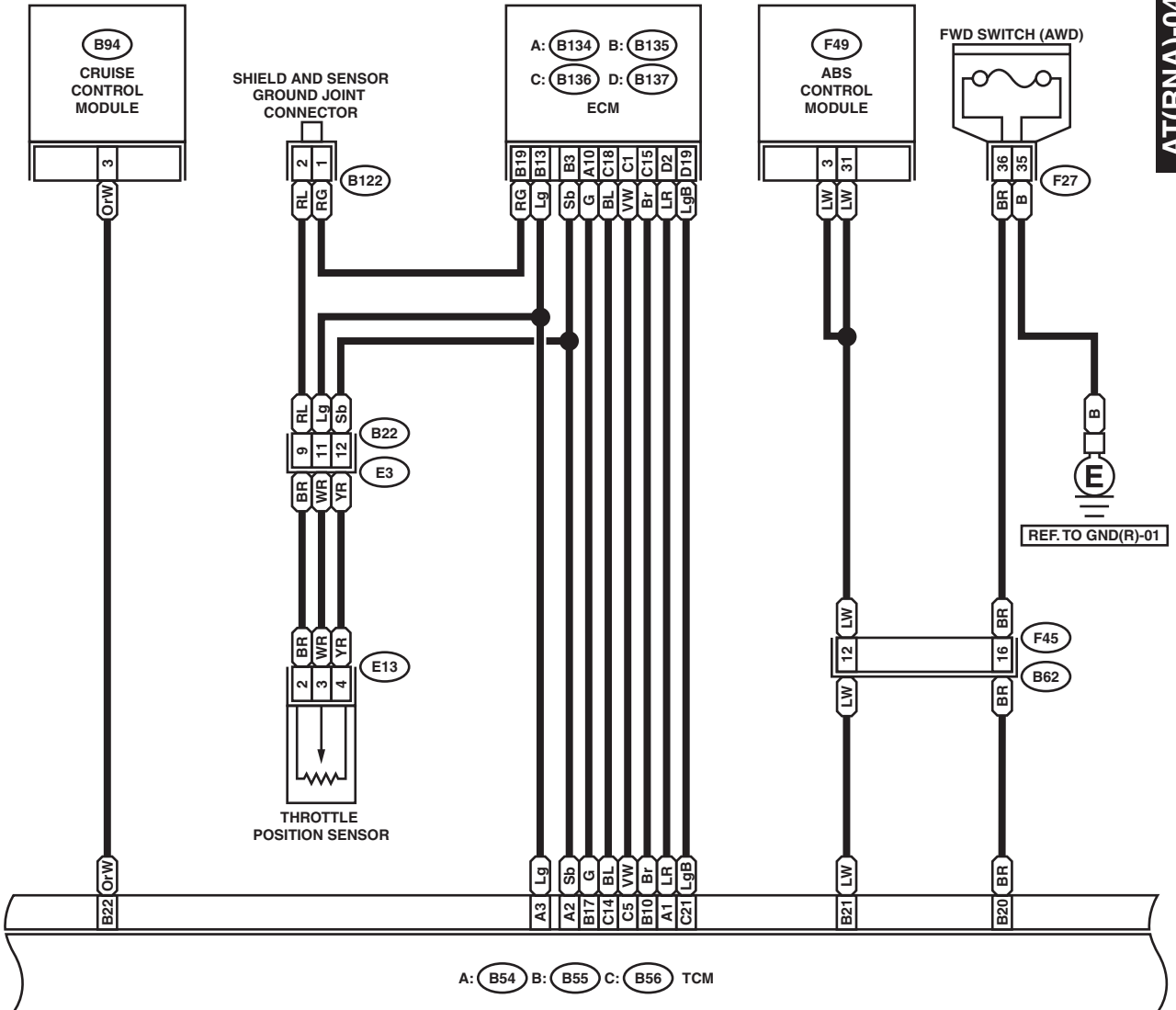

RELAY HOLDER

WI-03242

AT Control System

WIRING SYSTEM

AT(RNA)-05

AT(RNA)-05

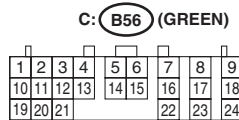
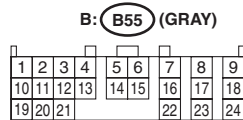
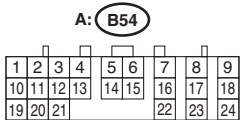
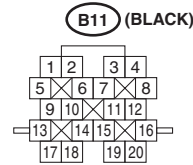
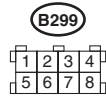
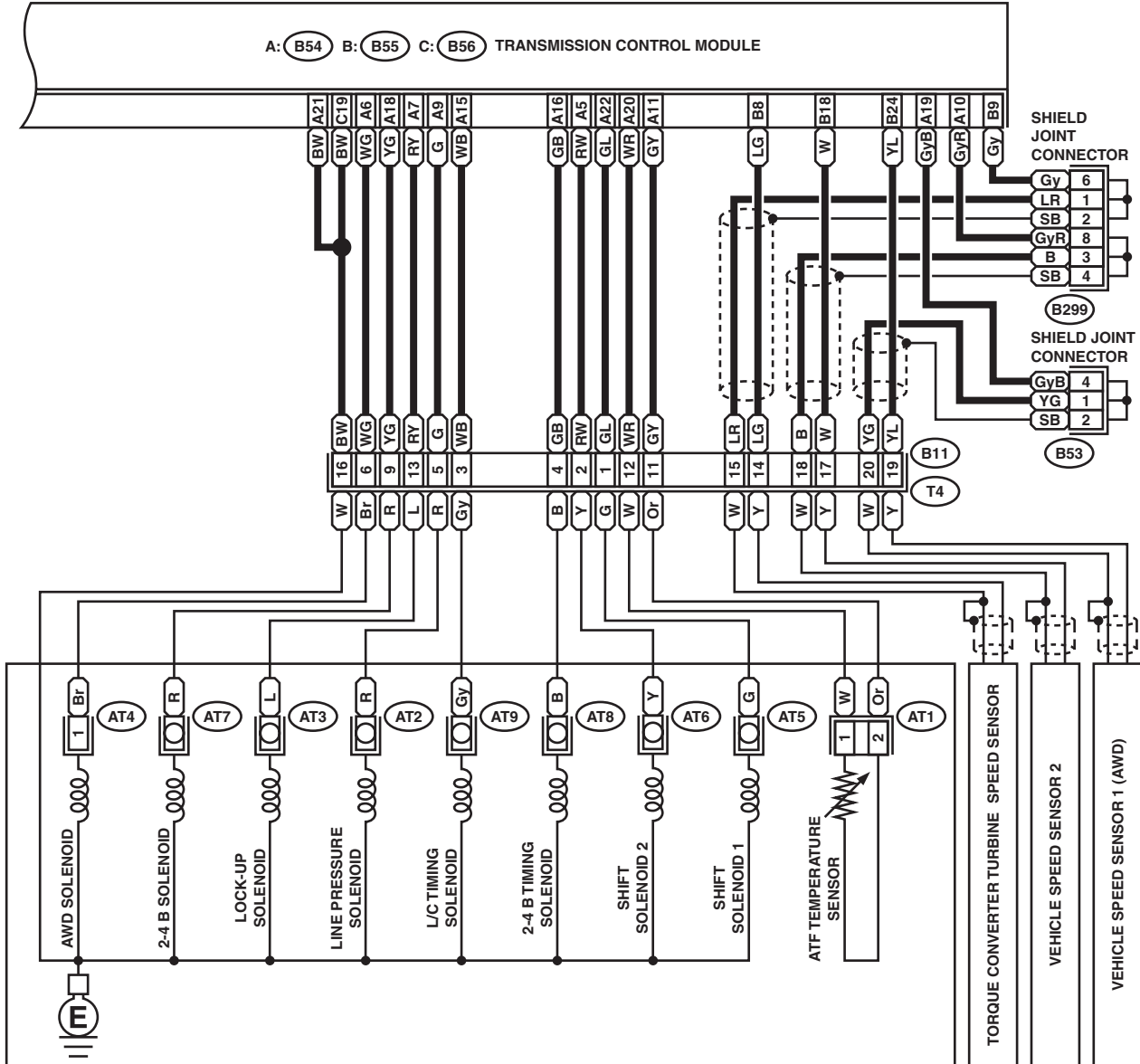

WI-00307

4. RHD TURBO MODEL

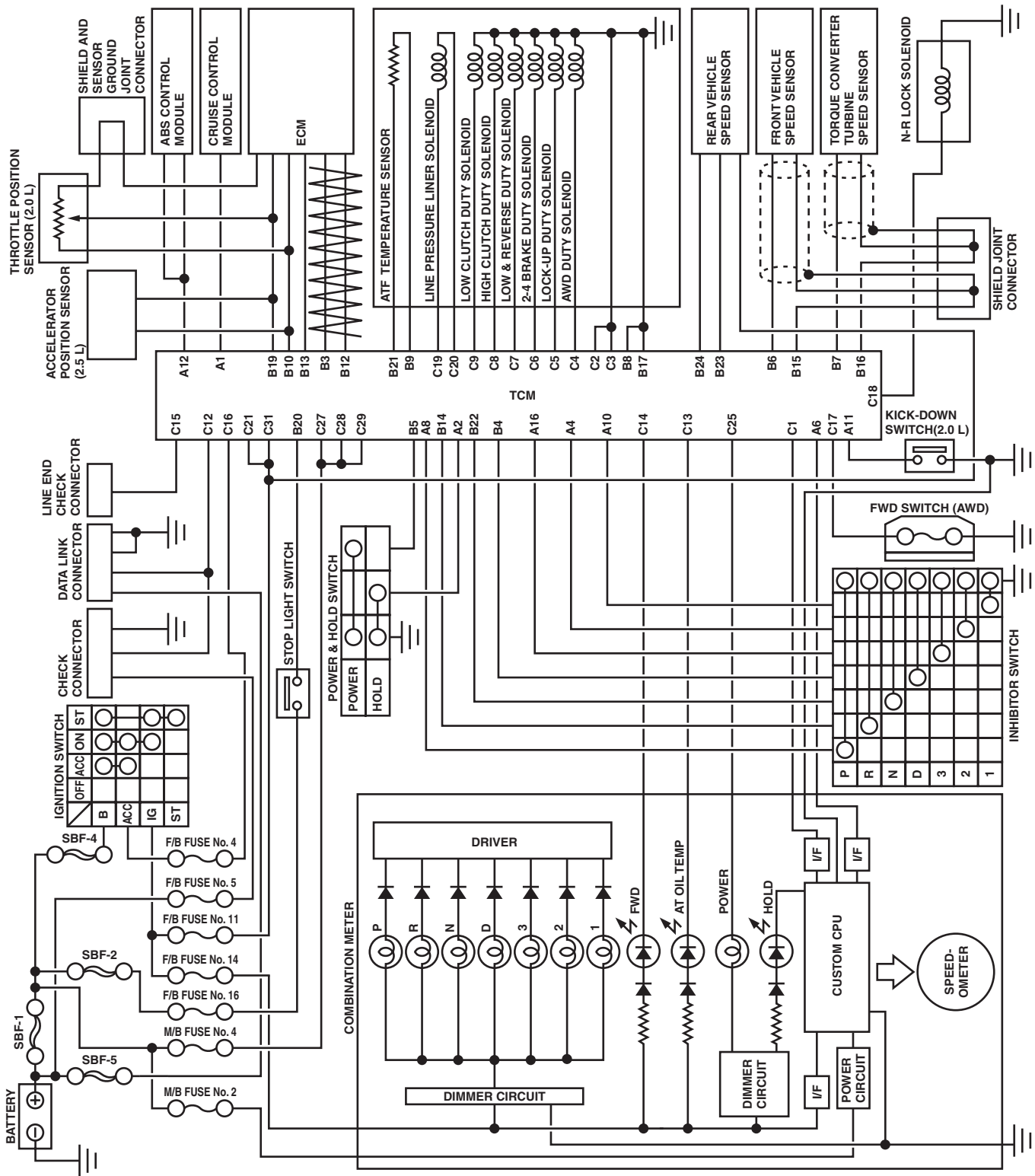

WI-03243

AT Control System

WIRING SYSTEM

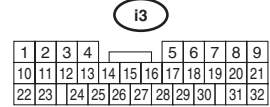
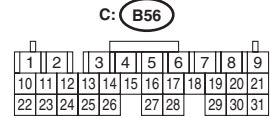
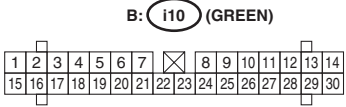
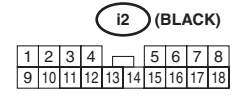
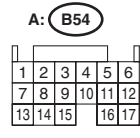
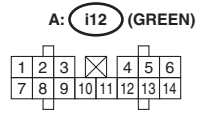
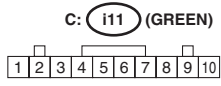
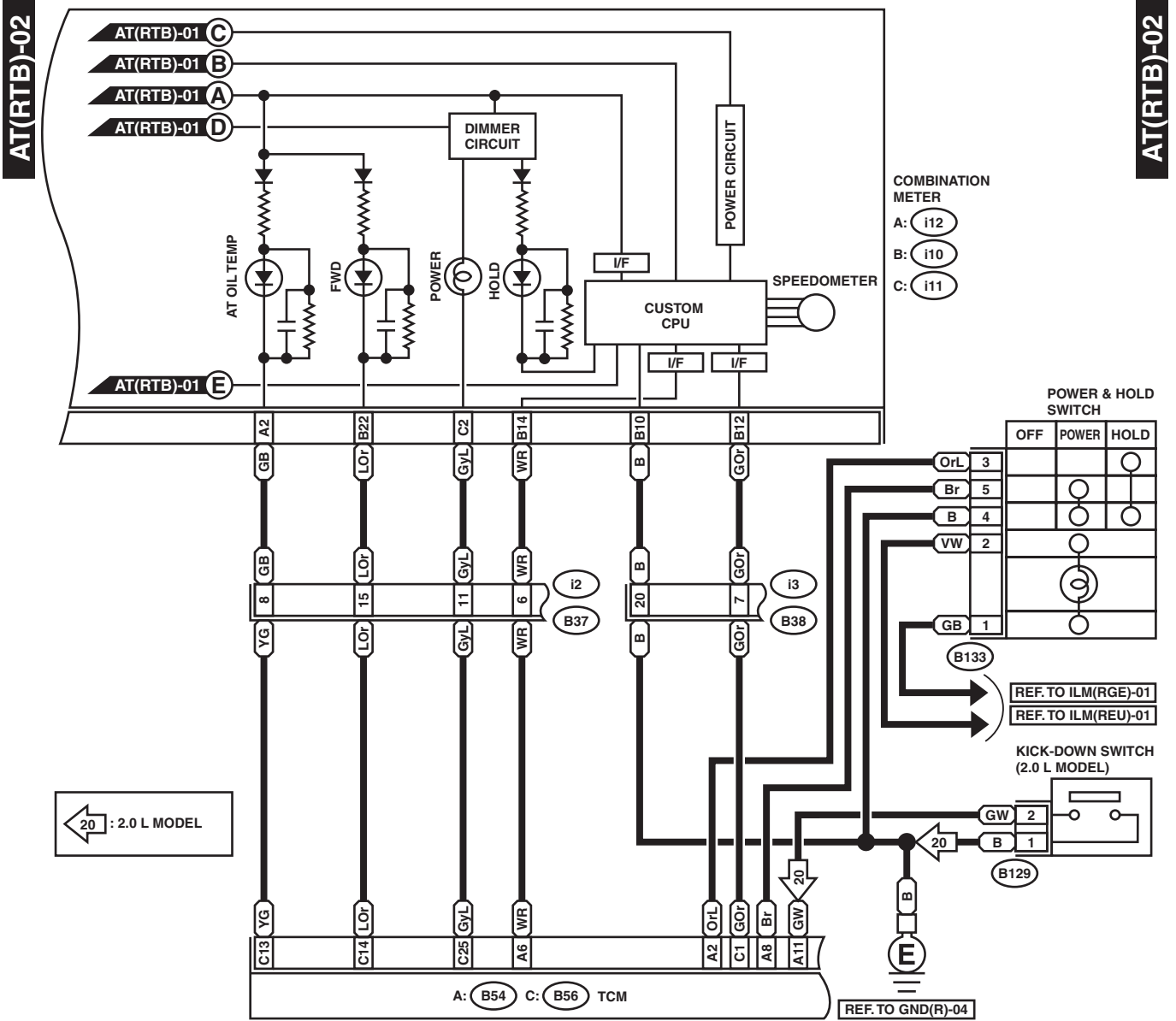

WI-03245

AT Control System

WIRING SYSTEM

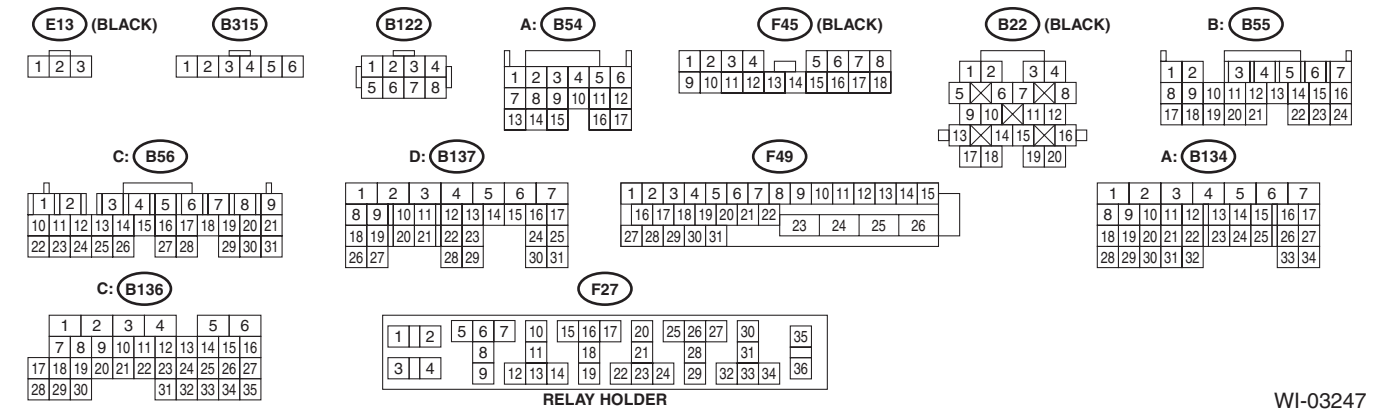
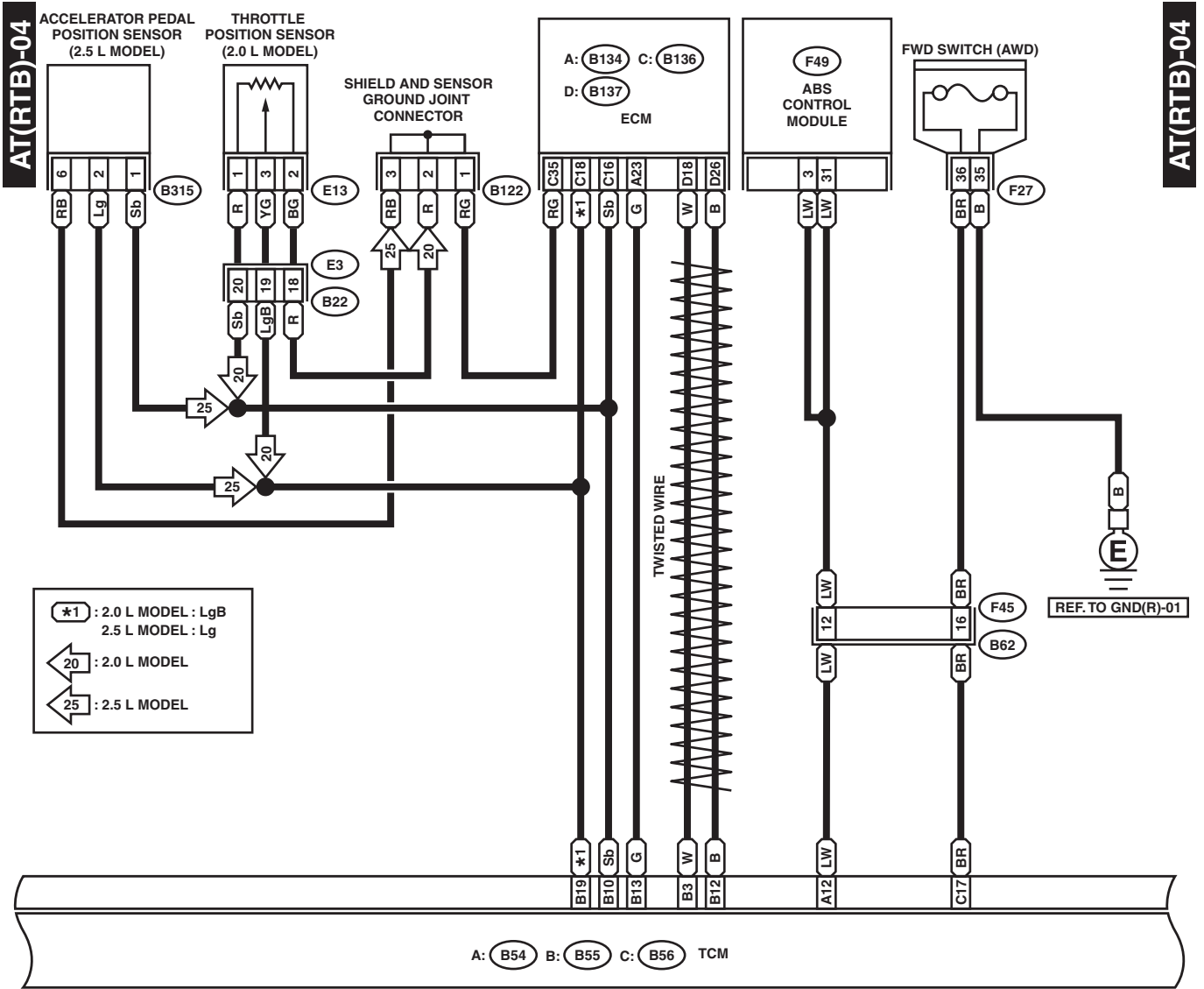

WI-03247

AT Control System

WIRING SYSTEM

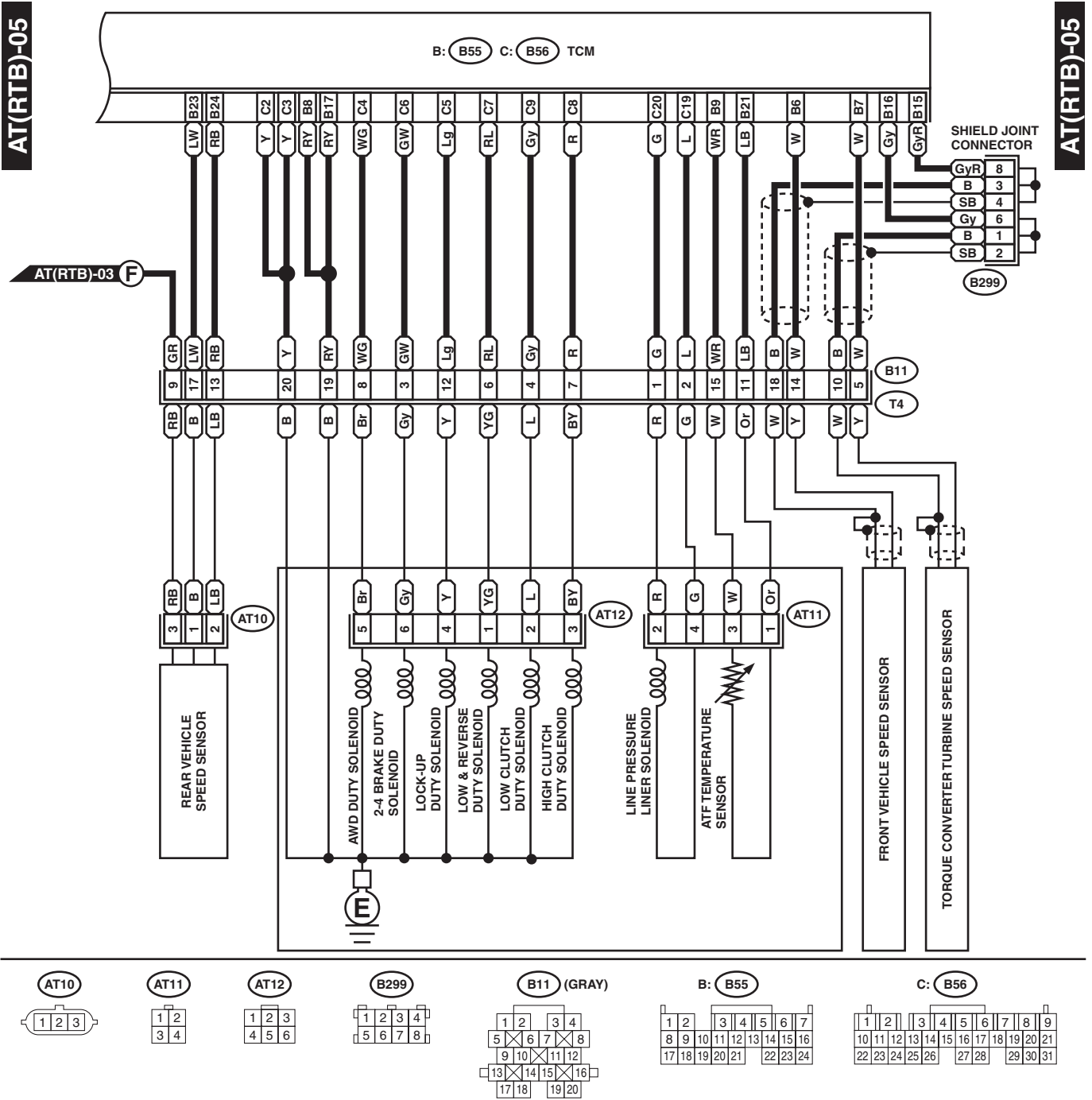

WI-03248

9. Audio System

A: WIRING DIAGRAM

1. LHD MODEL

AUDIO(L)-01

AUDIO(L)-01

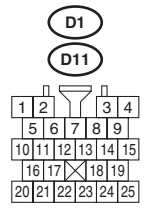
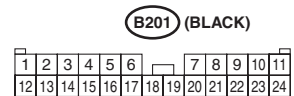
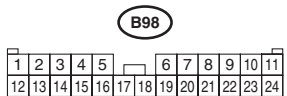
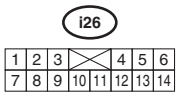
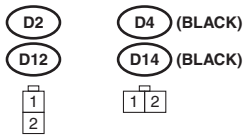
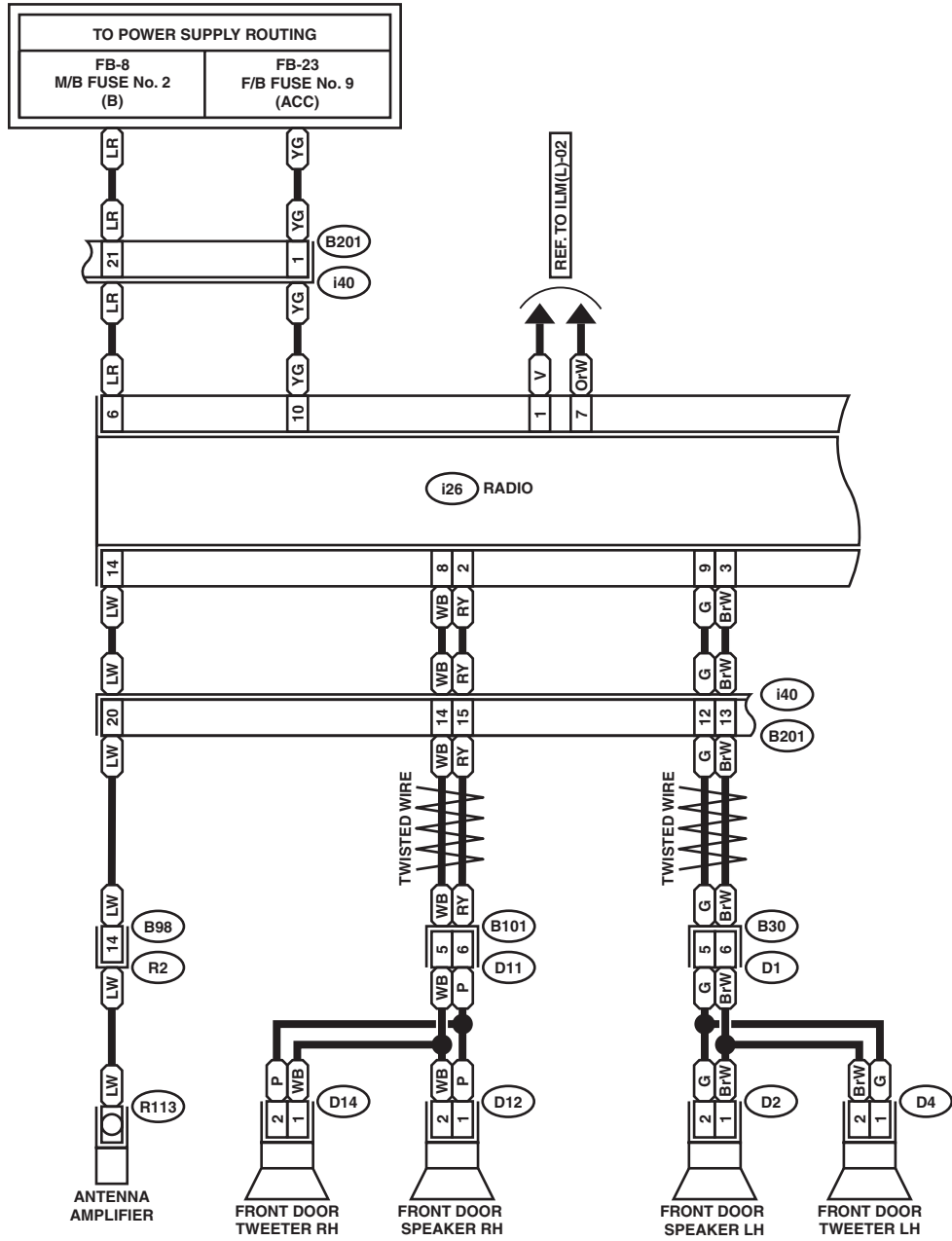

Audio System

WIRING SYSTEM

AUDIO(L)-02

AUDIO(L)-02

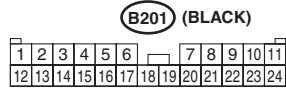
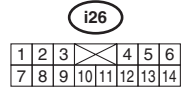
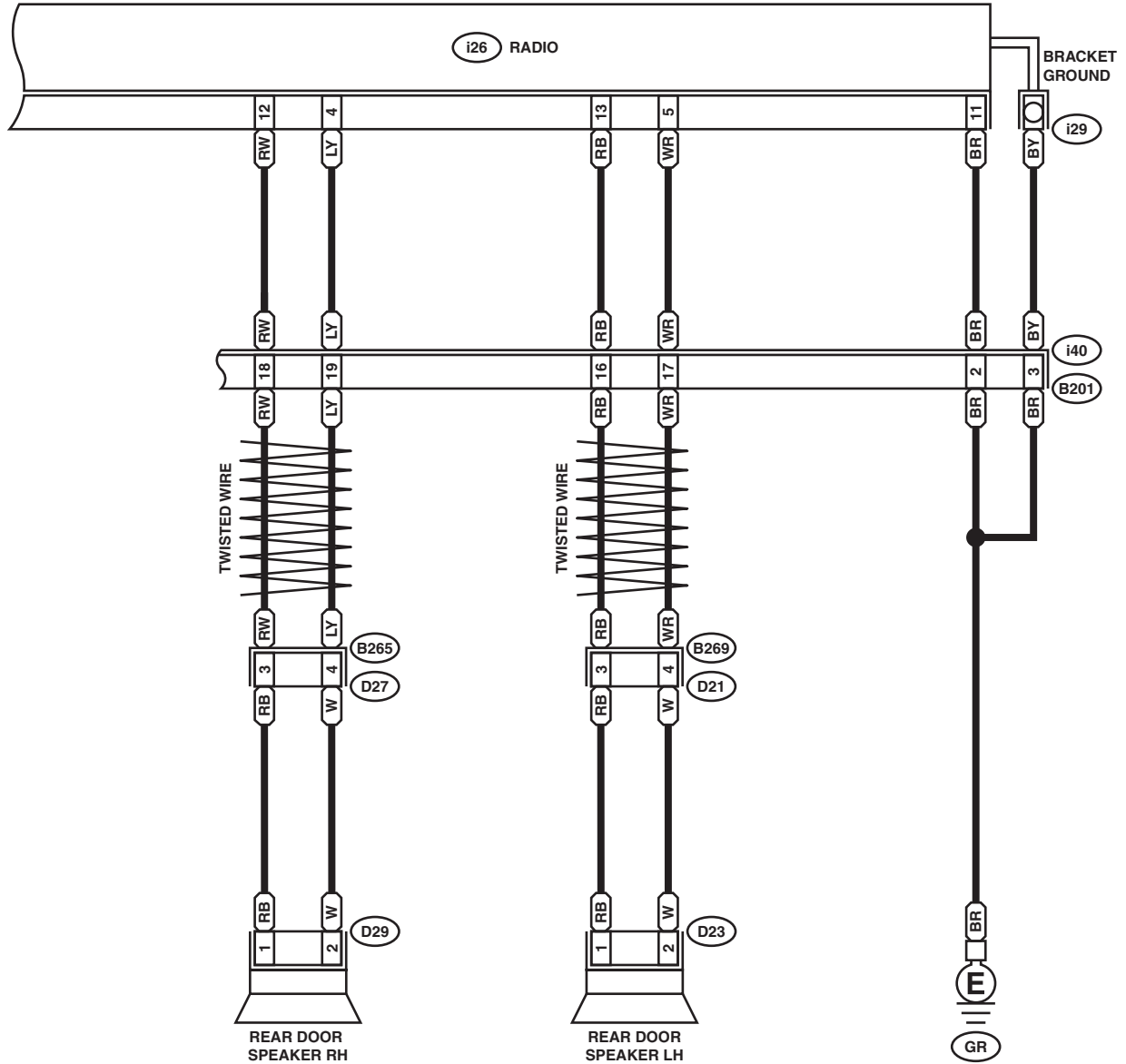

WI-00313

Audio System

WIRING SYSTEM

2. RHD MODEL

AUDIO(R)-01

AUDIO(R)-01

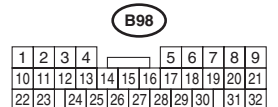
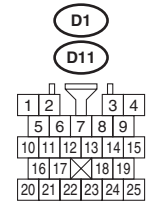
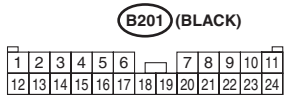
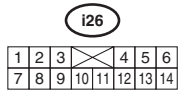
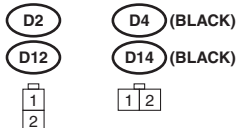
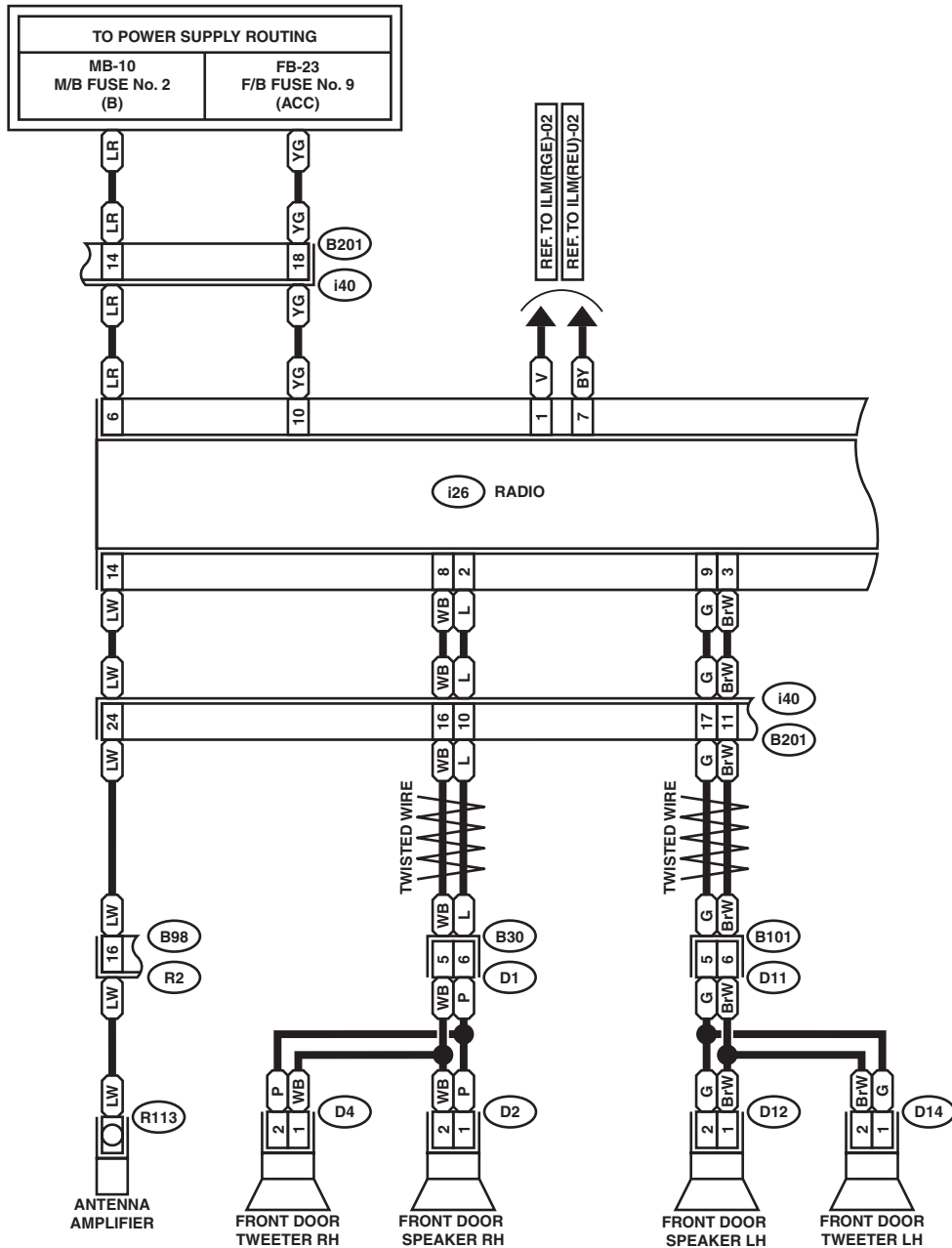

WI-03250

Audio System

WIRING SYSTEM

AUDIO(R)-02

AUDIO(R)-02

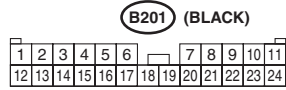
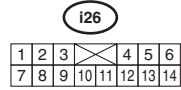
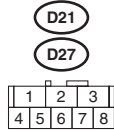
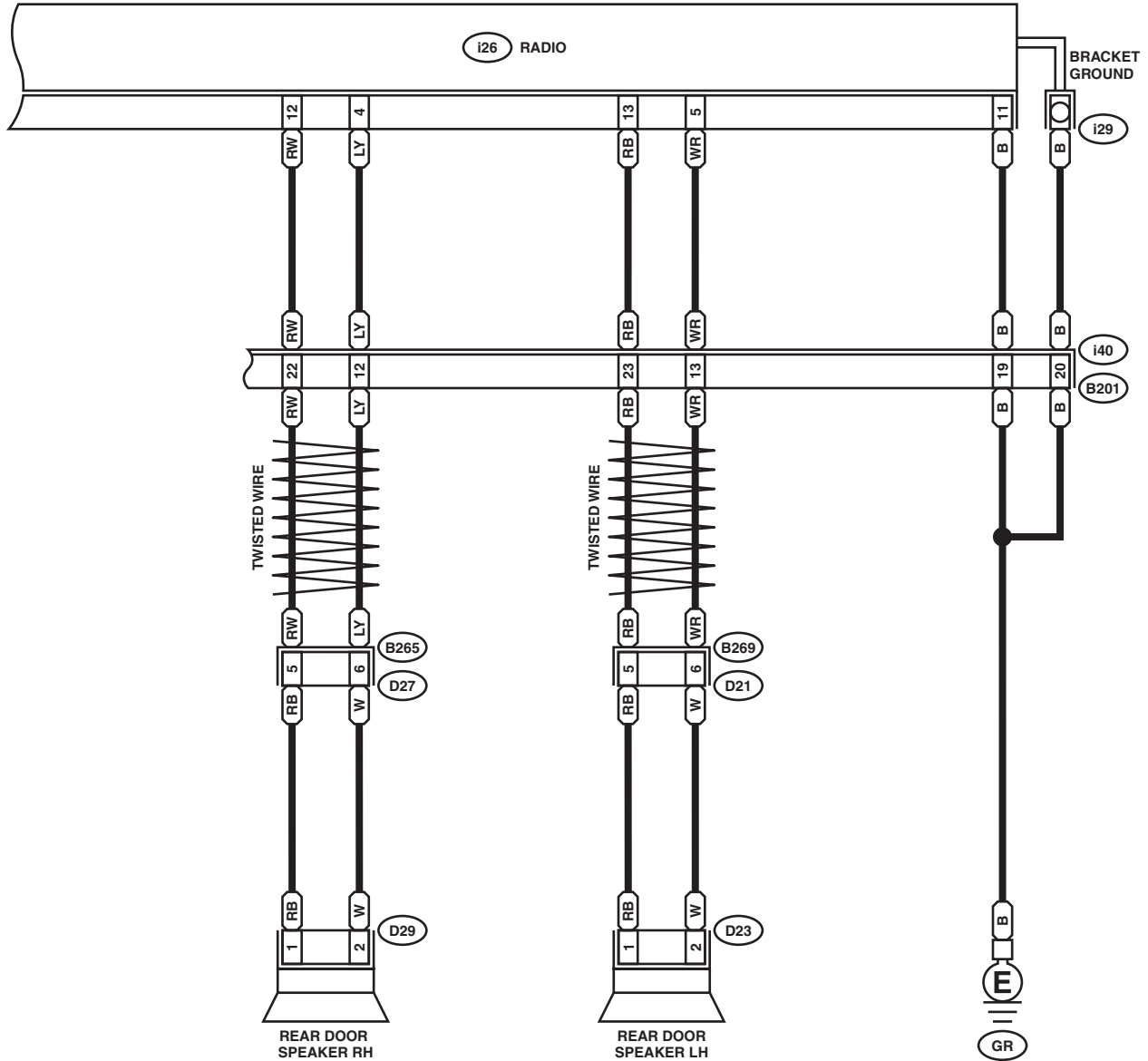

WI-03251

10. Charging System

A: WIRING DIAGRAM

CHG-01

CHG-01

