

ENGINE SECTION 1

This service manual has been prepared to provide SUBARU service personnel with the necessary information and data for the correct maintenance and repair of SUBARU vehicles.

This manual includes the procedures for maintenance, disassembling, reassembling, inspection and adjustment of components and diagnostics for guidance of experienced mechanics.

Please peruse and utilize this manual fully to ensure complete repair work for satisfying our customers by keeping their vehicle in optimum condition. When replacement of parts during repair work is needed, be sure to use SUBARU genuine parts.

All information, illustration and specifications contained in this manual are based on the latest product information available at the time of publication approval.

FUEL INJECTION (FUEL SYSTEM) FU(H4SO)

EMISSION CONTROL (AUX. EMISSION CONTROL DEVICE) EC(H4SO)

INTAKE (INDUCTION) IN(H4SO)

MECHANICAL ME(H4SO)

EXHAUST EX(H4SO)

COOLING CO(H4SO)

LUBRICATION LU(H4SO)

SPEED CONTROL SYSTEM SP(H4SO)

IGNITION IG(H4SO)

STARTING/CHARGING SYSTEM SC(H4SO)

ENGINE (DIAGNOSTIC) EN(H4SO)

MECHANICAL

ME(H4SO)

	Page
1. General Description	2
2. Compression	25
3. Idle Speed	26
4. Ignition Timing	27
5. Intake Manifold Vacuum.....	28
6. Engine Oil Pressure	29
7. Fuel Pressure	30
8. Valve Clearance	31
9. Engine Assembly	34
10. Engine Mounting	41
11. Preparation for Overhaul.....	42
12. V-belt.....	43
13. Crank Pulley.....	45
14. Timing Belt Cover.....	47
15. Timing Belt	48
16. Cam Sprocket	53
17. Crank Sprocket	55
18. Valve Rocker Assembly	56
19. Camshaft.....	58
20. Cylinder Head	62
21. Cylinder Block	69
22. Engine Trouble in General	91
23. Engine Noise.....	96

16. Cam Sprocket

A: REMOVAL

1. REMOVAL

- 1) Remove the V-belt. <Ref. to ME(H4SO)-43, REMOVAL, V-belt.>
 - 2) Remove the crank pulley. <Ref. to ME(H4SO)-45, REMOVAL, Crank Pulley.>
 - 3) Remove the belt cover. <Ref. to ME(H4SO)-47, REMOVAL, Timing Belt Cover.>
 - 4) Remove the timing belt assembly. <Ref. to ME(H4SO)-48, REMOVAL, Timing Belt.>
 - 5) Remove the camshaft position sensor. <Ref. to FU(H4SO)-27, REMOVAL, Camshaft Position Sensor.>
 - 6) Remove the cam sprocket No. 2. To lock the camshaft, use ST.
- ST 18231AA010 CAM SPROCKET WRENCH

NOTE:

Also the CAM SPROCKET WRENCH (499207100) can be used.

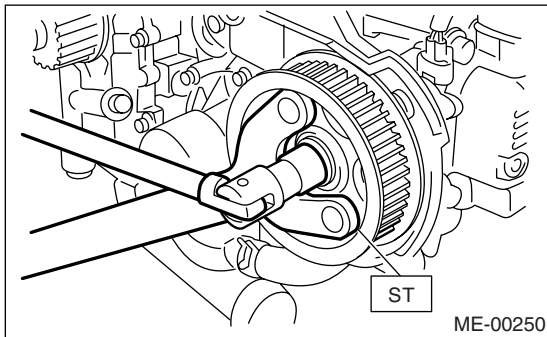

- 7) Remove the cam sprocket No. 1. Use ST to lock the camshaft.

ST 499207400 CAM SPROCKET WRENCH

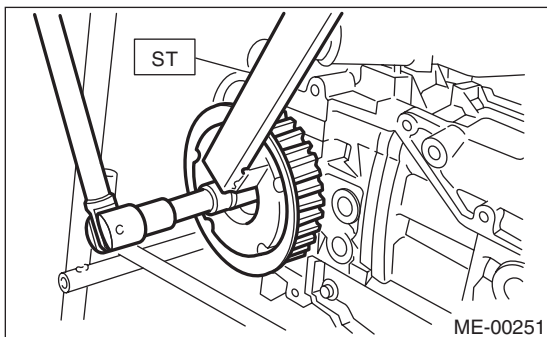

B: INSTALLATION

- 1) Install the cam sprocket No. 1. To lock the camshaft, use ST.

ST 499207400 CAM SPROCKET WRENCH

Tightening torque:

78 N·m (8.0 kgf-m, 57.9 ft-lb)

NOTE:

Do not confuse the right and left side cam sprockets during installation. The cam sprocket No. 2 is identified by a projection used to monitor camshaft position sensor.

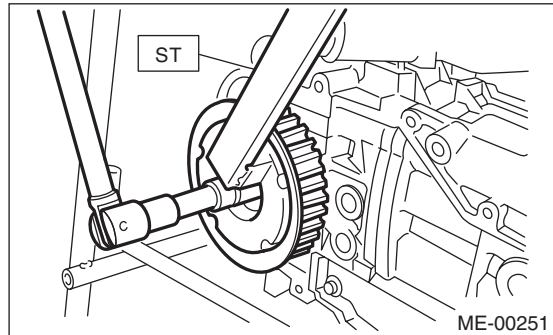

- 2) Install the cam sprocket No. 2. Use ST to lock camshaft.

ST 18231AA010 CAM SPROCKET WRENCH

NOTE:

Also the CAM SPROCKET WRENCH (499207100) can be used.

Tightening torque:

78 N·m (8.0 kgf-m, 57.9 ft-lb)

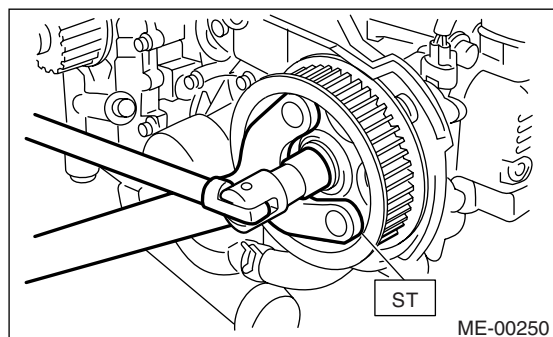

- 3) Install the camshaft position sensor. <Ref. to FU(H4SO)-27, INSTALLATION, Camshaft Position Sensor.>

- 4) Install the timing belt assembly. <Ref. to ME(H4SO)-49, INSTALLATION, Timing Belt.>

- 5) Install the belt cover. <Ref. to ME(H4SO)-47, INSTALLATION, Timing Belt Cover.>

- 6) Install the crank pulley. <Ref. to ME(H4SO)-45, INSTALLATION, Crank Pulley.>

- 7) Install the V-belt. <Ref. to ME(H4SO)-43, INSTALLATION, V-belt.>

Cam Sprocket

MECHANICAL

C: INSPECTION

- 1) Check the cam sprocket teeth for abnormal wear and scratches.
- 2) Make sure there is no free play between cam sprocket and key.
- 3) Check the cam sprocket notch for sensor for damage and contamination of foreign matter.

17. Crank Sprocket

A: REMOVAL

- 1) Remove the V-belt. <Ref. to ME(H4SO)-43, REMOVAL, V-belt.>
- 2) Remove the crank pulley. <Ref. to ME(H4SO)-45, REMOVAL, Crank Pulley.>
- 3) Remove the belt cover. <Ref. to ME(H4SO)-47, REMOVAL, Timing Belt Cover.>
- 4) Remove the timing belt assembly. <Ref. to ME(H4SO)-48, REMOVAL, Timing Belt.>
- 5) Remove the cam sprocket. <Ref. to ME(H4SO)-53, REMOVAL, Cam Sprocket.>
- 6) Remove the crank sprocket.

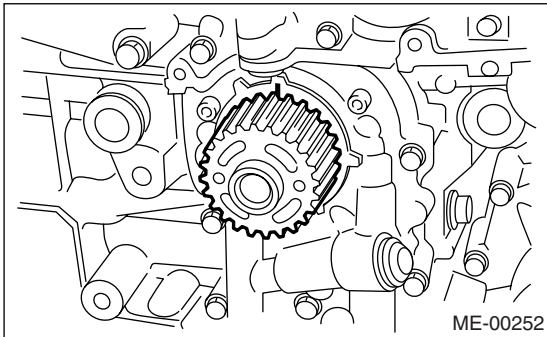

B: INSTALLATION

- 1) Install the crank sprocket.

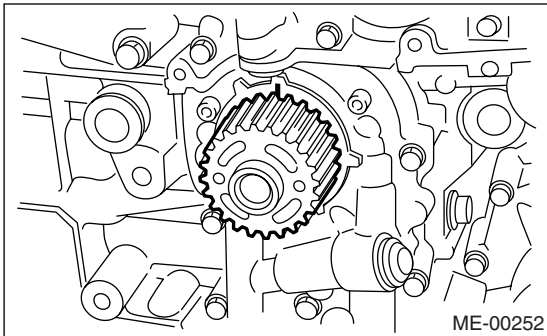

- 2) Install the cam sprocket. <Ref. to ME(H4SO)-53, INSTALLATION, Cam Sprocket.>
- 3) Install the timing belt assembly. <Ref. to ME(H4SO)-49, INSTALLATION, Timing Belt.>
- 4) Install the belt cover. <Ref. to ME(H4SO)-47, INSTALLATION, Timing Belt Cover.>
- 5) Install the crank pulley. <Ref. to ME(H4SO)-45, INSTALLATION, Crank Pulley.>
- 6) Install the V-belt. <Ref. to ME(H4SO)-43, INSTALLATION, V-belt.>

C: INSPECTION

- 1) Check the crank sprocket teeth for abnormal wear and scratches.
- 2) Make sure there is no free play between crank sprocket and key.
- 3) Check the crank sprocket notch for sensor for damage and contamination of foreign matter.

Valve Rocker Assembly

MECHANICAL

18. Valve Rocker Assembly

A: REMOVAL

- 1) Remove the V-belt. <Ref. to ME(H4SO)-43, REMOVAL, V-belt.>
- 2) Remove the crank pulley. <Ref. to ME(H4SO)-45, REMOVAL, Crank Pulley.>
- 3) Remove the belt cover. <Ref. to ME(H4SO)-47, REMOVAL, Timing Belt Cover.>
- 4) Remove the timing belt assembly. <Ref. to ME(H4SO)-48, REMOVAL, Timing Belt.>
- 5) Remove the cam sprocket. <Ref. to ME(H4SO)-53, REMOVAL, Cam Sprocket.>
- 6) Disconnect the PCV hose and remove rocker cover.
- 7) Removal of valve rocker assembly
 - (1) Remove the bolts (a) through (h) in alphabetical sequence.

NOTE:

Leave two or three threads of bolts (g and h) engaged to retain the valve rocker assembly.

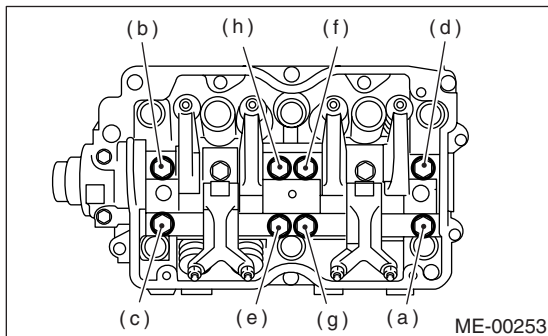

- (2) Remove the valve rocker assembly.

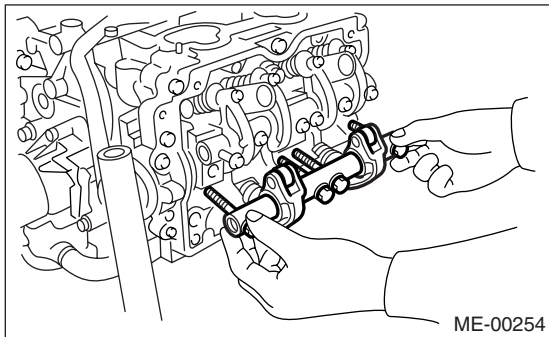

B: INSTALLATION

- 1) Installation of valve rocker assembly
 - (1) Temporarily tighten the bolts (a) through (d) equally as shown in the figure.

NOTE:

Do not allow the valve rocker assembly to gouge knock pins.

- (2) Tighten the bolts (e) through (h) to specified torque.
- (3) Tighten the bolts (a) through (d) to specified torque.

Tightening torque:

25 N·m (2.5 kgf·m, 18.1 ft·lb)

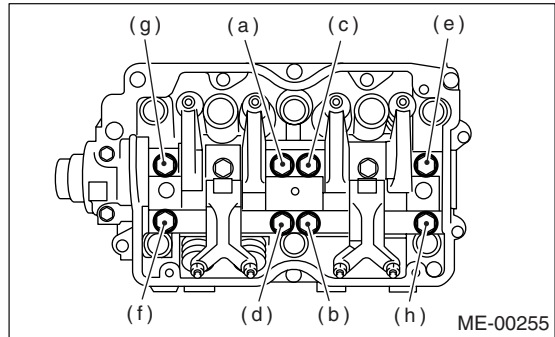

- 2) Adjust the valve clearances. <Ref. to ME(H4SO)-32, ADJUSTMENT, Valve Clearance.>
- 3) Install the rocker cover and connect PCV hose.
- 4) Install the cam sprocket. <Ref. to ME(H4SO)-53, INSTALLATION, Cam Sprocket.>
- 5) Install the timing belt assembly. <Ref. to ME(H4SO)-49, INSTALLATION, Timing Belt.>
- 6) Install the belt cover. <Ref. to ME(H4SO)-47, INSTALLATION, Timing Belt Cover.>
- 7) Install the crank pulley. <Ref. to ME(H4SO)-45, INSTALLATION, Crank Pulley.>
- 8) Install the V-belt. <Ref. to ME(H4SO)-43, INSTALLATION, V-belt.>

C: DISASSEMBLY

- 1) Remove the bolts which secure rocker shaft.
- 2) Extract the rocker shaft. Remove the valve rocker arms, springs and shaft supports from rocker shaft.

NOTE:

Arrange all removed parts in order so that they can be installed in their original positions.

- 3) Remove the nut and adjusting screw from valve rocker.

D: ASSEMBLY

- 1) Install the adjusting screw and nut to valve rocker.
- 2) Arrange the valve rocker arms, springs and shaft supports in assembly order and insert valve rocker shaft.

Tightening torque (Shaft supports installing bolts):

5 N·m (0.5 kgf·m, 3.6 ft·lb)

NOTE:

Valve rocker arms, rocker shaft and shaft supports have identification marks. Ensure the parts with same markings are properly assembled.

- 3) Install the valve rocker shaft securing bolts.

E: INSPECTION

1. VALVE ROCKER ARM AND ROCKER SHAFT

- 1) Measure the inside diameter of valve rocker arm and outside diameter of valve rocker shaft, and determine the difference between the two (= oil clearance).

Clearance between arm and shaft:

Standard

0.020 — 0.054 mm (0.0008 — 0.0021 in)

Limit

0.10 mm (0.0039 in)

- 2) If oil clearance exceeds the limit, replace the valve rocker arm or shaft, whichever shows greater amount of wear.

Rocker arm inside diameter:

22.020 — 22.041 mm (0.8669 — 0.8678 in)

Rocker shaft diameter:

21.987 — 22.000 mm (0.8656 — 0.8661 in)

- 3) If cam or valve contact surface of valve rocker arm is worn or dented excessively, replace the valve rocker arm.
- 4) Check that the valve rocker arm roller rotates smoothly. If not, replace the valve rocker arm.

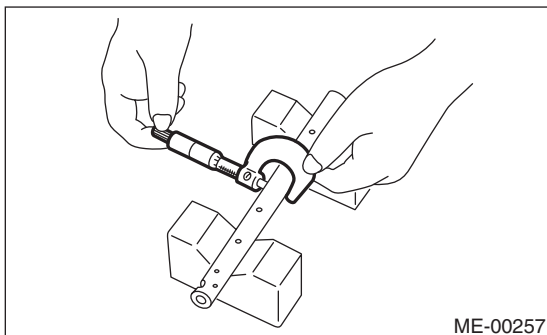
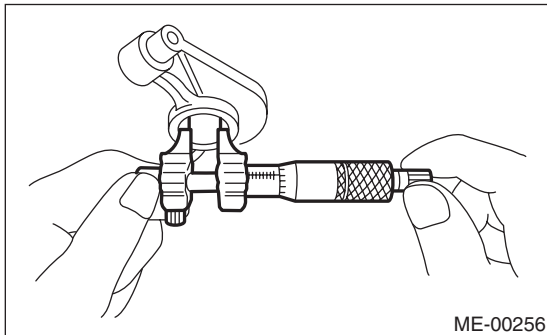

19. Camshaft

A: REMOVAL

- 1) Remove the V-belt. <Ref. to ME(H4SO)-43, INSTALLATION, V-belt.>
- 2) Remove the crank pulley. <Ref. to ME(H4SO)-45, REMOVAL, Crank Pulley.>
- 3) Remove the belt cover. <Ref. to ME(H4SO)-47, REMOVAL, Timing Belt Cover.>
- 4) Remove the timing belt assembly. <Ref. to ME(H4SO)-48, REMOVAL, Timing Belt.>
- 5) Remove the cam sprocket. <Ref. to ME(H4SO)-53, REMOVAL, Cam Sprocket.>
- 6) Remove the crank sprocket. <Ref. to ME(H4SO)-55, REMOVAL, Crank Sprocket.>
- 7) Remove the belt cover No. 2 (LH).
- 8) Remove the belt cover No. 2 (RH).

NOTE:

Do not damage or lose the seal rubber when removing belt covers.

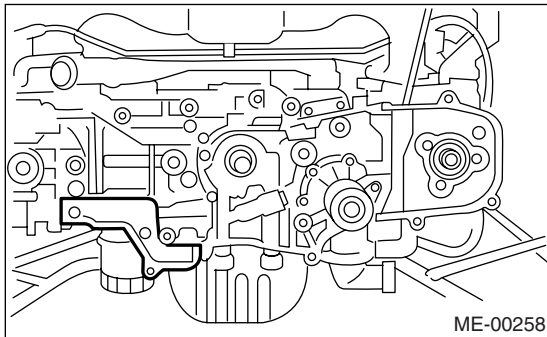

- 9) Remove the tensioner bracket.

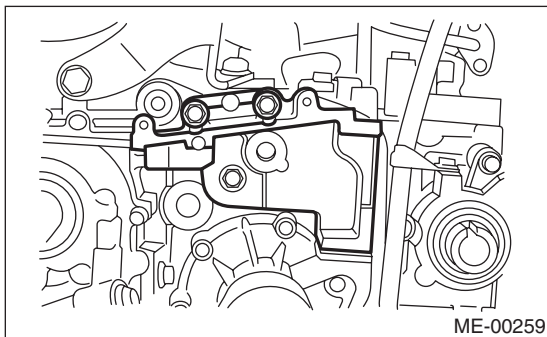

- 10) Remove the camshaft position sensor support. (LH side only)
- 11) Remove the oil level gauge guide. (LH side only)
- 12) Remove the valve rocker assembly. <Ref. to ME(H4SO)-56, REMOVAL, Valve Rocker Assembly.>
- 13) Remove the camshaft cap.

- (1) Remove the bolts (a) through (b) in alphabetical sequence.

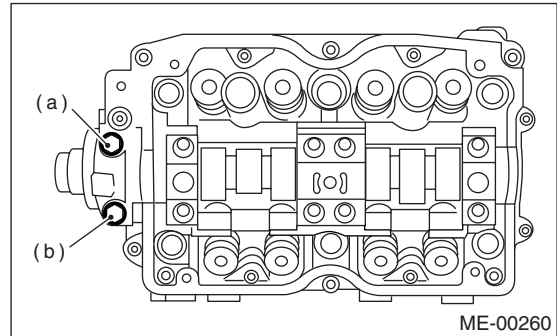

- (2) Equally loosen the bolts (c) through (j) all the way in alphabetical sequence.

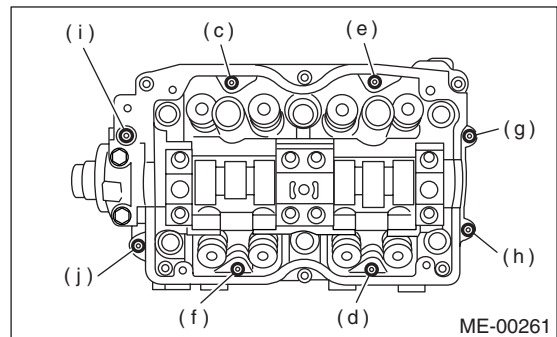

- (3) Remove the bolts (k) through (p) in alphabetical sequence using ST.

ST 499497000 TORX PLUS

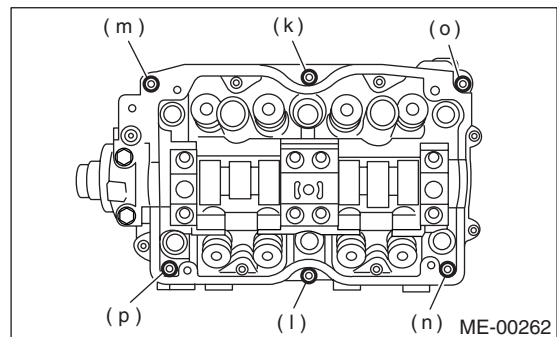

- (4) Remove the camshaft cap.

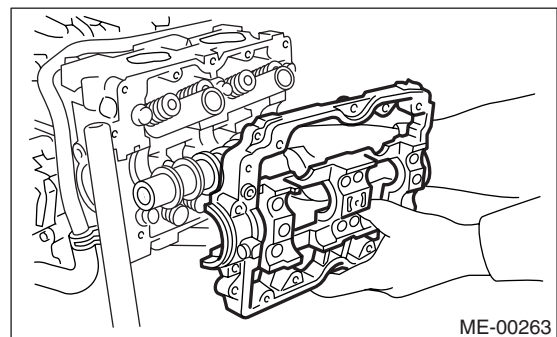

- 14) Remove the camshaft.
- 15) Remove the oil seal.

16) Remove the plug from rear side of camshaft.

CAUTION:

- Do not remove the oil seal unless necessary.
- Do not scratch the journal surface when removing oil seal.

B: INSTALLATION

- 1) Apply a coat of engine oil to the camshaft journals, and then install the camshaft.
- 2) Install the camshaft cap.

- (1) Apply liquid gasket on the around of camshaft cap.

Liquid gasket:

THREE BOND 1280B (Part No. K0877YA018)

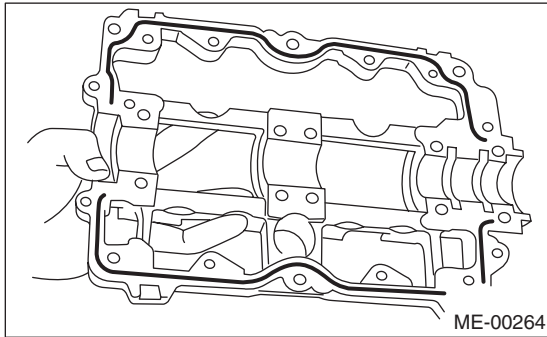

NOTE:

Apply a coat of 3 mm (0.12 in) dia (A), liquid gasket along edge (B) of the camshaft cap (C) mating surface.

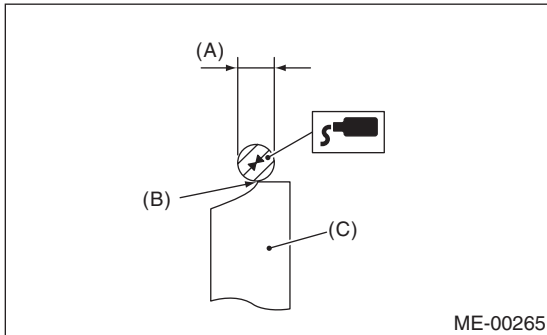

- (2) Temporarily tighten the bolts (g) through (j) in alphabetical sequence.

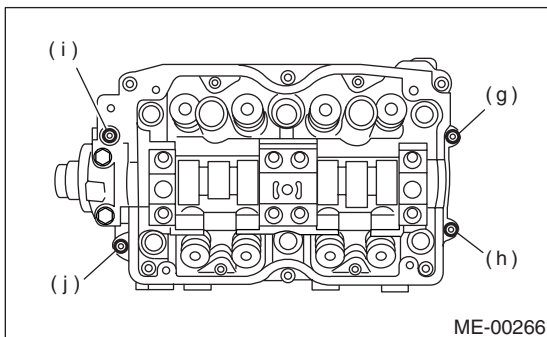

- (3) Install the valve rocker assembly.

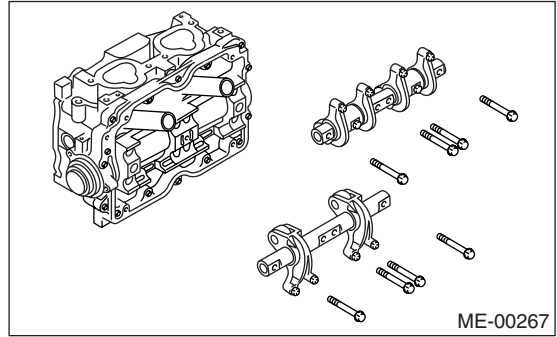

- (4) Tighten the bolts (a) through (h) in alphabetical sequence.

Tightening torque:

25 N·m (2.5 kgf-m, 18.1 ft-lb)

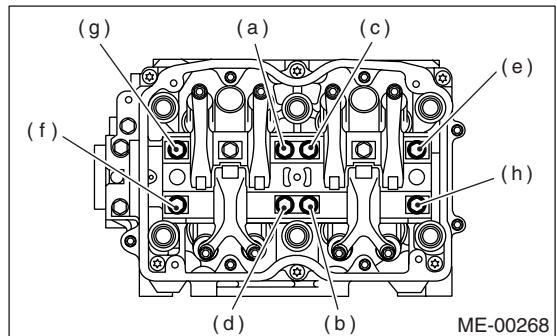

- (5) Tighten the TORX bolts (i) through (n) in alphabetical sequence using ST.

ST 499497000 TORX PLUS

Tightening torque:

18 N·m (1.8 kgf-m, 13.0 ft-lb)

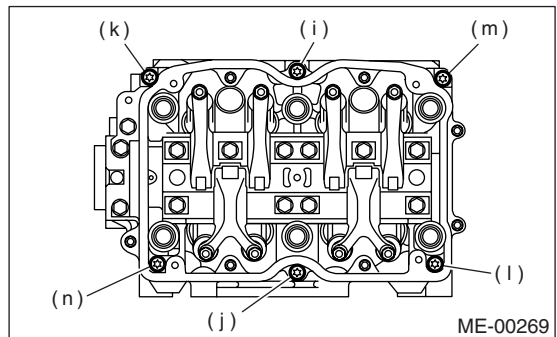

Camshaft

MECHANICAL

(6) Tighten the bolts (o) through (v) in alphabetical sequence.

Tightening torque:

10 N·m (1.0 kgf·m, 7.2 ft·lb)

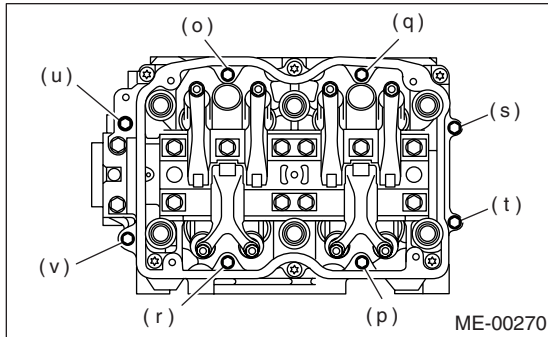

(7) Tighten the bolts (w) through (x) in alphabetical sequence.

Tightening torque:

10 N·m (1.0 kgf·m, 7.2 ft·lb)

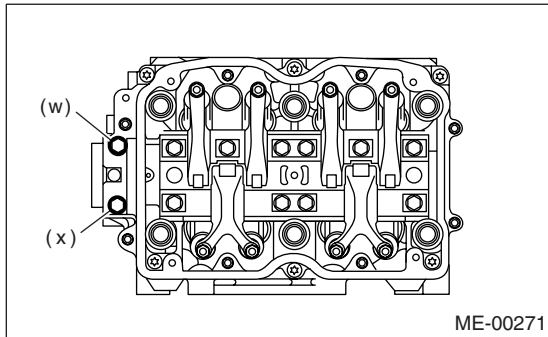

3) Apply a coat of grease to oil seal lips, and then install the oil seal (A) on camshaft using ST1 and ST2.

NOTE:

Use a new oil seal.

ST1	499597000	OIL SEAL GUIDE
ST2	499587500	OIL SEAL INSTALLER

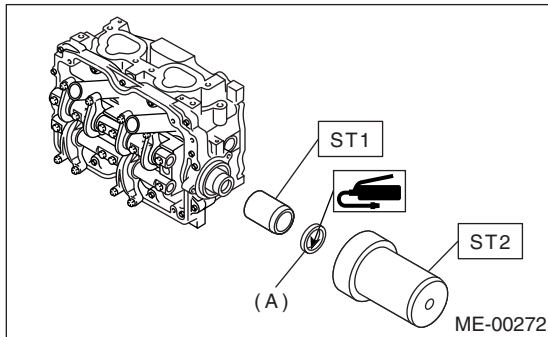

4) Install the plug using ST.

ST	499587700	CAMSHAFT OIL SEAL INSTALLER
----	-----------	-----------------------------

5) Adjust the valve clearance. <Ref. to ME(H4SO)-32, ADJUSTMENT, Valve Clearance.>

6) Install the rocker cover and connect PCV hose.

7) Install the oil level gauge guide. (LH side only)

8) Install the camshaft position sensor support. (LH side only)

9) Install the tensioner bracket.

Tightening torque:

25 N·m (2.5 kgf·m, 18.1 ft·lb)

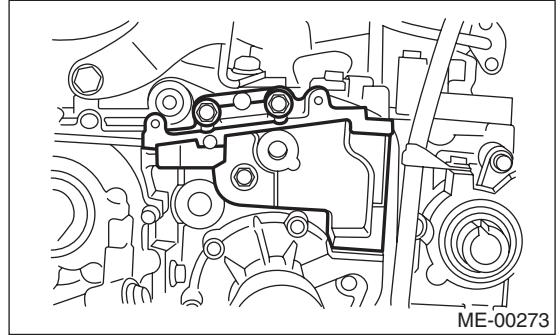

10) Install the belt cover No. 2 (RH).

Tightening torque:

5 N·m (0.5 kgf·m, 3.6 ft·lb)

11) Install the belt cover No. 2 (LH).

Tightening torque:

5 N·m (0.5 kgf·m, 3.6 ft·lb)

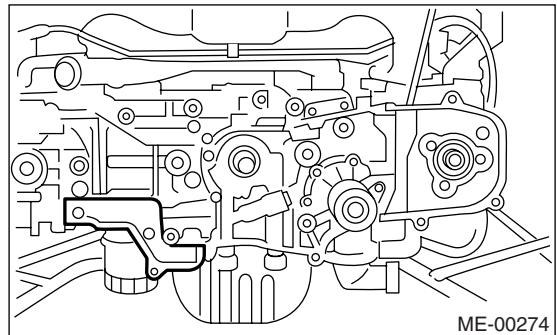

12) Install the crank sprocket. <Ref. to ME(H4SO)-55, INSTALLATION, Crank Sprocket.>

13) Install the cam sprocket. <Ref. to ME(H4SO)-53, INSTALLATION, Cam Sprocket.>

14) Install the timing belt assembly. <Ref. to ME(H4SO)-49, INSTALLATION, Timing Belt.>

15) Install the belt cover. <Ref. to ME(H4SO)-47, INSTALLATION, Timing Belt Cover.>

16) Install the crank pulley. <Ref. to ME(H4SO)-45, INSTALLATION, Crank Pulley.>

17) Install the V-belt. <Ref. to ME(H4SO)-43, INSTALLATION, V-belt.>

C: INSPECTION

1. CAMSHAFT

1) Measure the bend, and repair or replace if necessary.

Limit:

0.025 mm (0.0010 in)

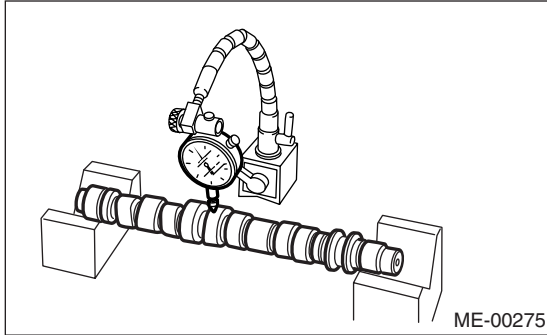

2) Check the journal for damage and wear. Replace if faulty.

3) Measure the outside diameter of camshaft journal and inside diameter of cylinder head journal, and determine the difference between two (= oil clearance). If the oil clearance exceeds specifications, replace the camshaft or cylinder head as necessary.

Unit: mm (in)		
Clearance at journal	Standard	0.055 — 0.090 (0.0022 — 0.0035)
	Limit	0.10 (0.0039)
Camshaft journal O.D.		31.928 — 31.945 (1.2570 — 1.2577)
Journal hole I.D.		32.000 — 32.018 (1.2598 — 1.2605)

4) Check the cam face condition; remove the minor faults by grinding with oil stone. Measure the cam height H; replace if the limit has been exceeded.

Cam height: H

Model	Item	Unit: mm (in)	
2.0 L	Intake	STD	38.732 — 38.832 (1.5249 — 1.528885)
		Limit	38.632 (1.5209)
	Exhaust	STD	39.259 — 39.359 (1.5456 — 1.5496)
		Limit	39.157 (1.5416)
2.5 L	Intake	STD	39.485 — 39.585 (1.5545 — 1.5585)
		Limit	39.385 (1.5506)
	Exhaust	STD	39.259 — 39.359 (1.5456 — 1.5496)
		Limit	39.157 (1.5416)

Cam base circle diameter A:

IN: 34.00 mm (1.3386 in)

EX: 34.00 mm (1.3386 in)

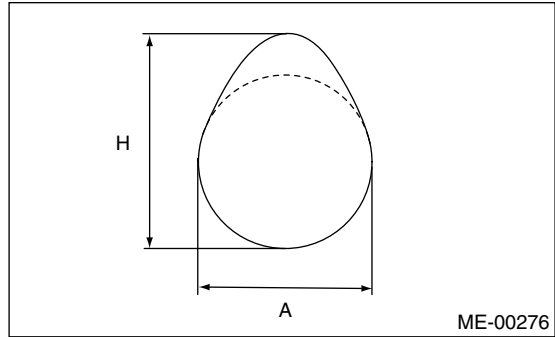

2. CAMSHAFT SUPPORT

Measure the thrust clearance of camshaft with dial gauge. If the clearance exceeds the limit, replace the camshaft support.

Standard:

0.030 — 0.090 mm (0.0012 — 0.0035 in)

Limit:

0.10 mm (0.0039 in)

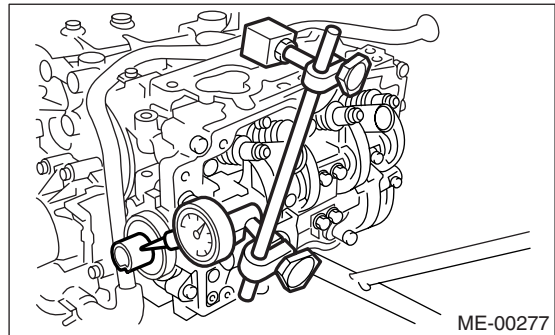

Cylinder Head

MECHANICAL

20. Cylinder Head

A: REMOVAL

- 1) Remove the V-belt. <Ref. to ME(H4SO)-43, REMOVAL, V-belt.>
- 2) Remove the crank pulley. <Ref. to ME(H4SO)-45, REMOVAL, Crank Pulley.>
- 3) Remove the timing belt cover. <Ref. to ME(H4SO)-47, REMOVAL, Timing Belt Cover.>
- 4) Remove the timing belt. <Ref. to ME(H4SO)-48, REMOVAL, Timing Belt.>
- 5) Remove the cam sprocket. <Ref. to ME(H4SO)-53, REMOVAL, Cam Sprocket.>
- 6) Remove the intake manifold. <Ref. to FU(H4SO)-14, REMOVAL, Intake Manifold.>
- 7) Remove the bolt which installs A/C compressor bracket on cylinder head.
- 8) Remove the valve rocker assembly. <Ref. to ME(H4SO)-56, REMOVAL, Valve Rocker Assembly.>
- 9) Remove the camshaft. <Ref. to ME(H4SO)-58, REMOVAL, Camshaft.>
- 10) Remove the cylinder head bolts in alphabetical sequence shown in the figure.

NOTE:

Leave the bolts (a) and (c) engaged by three or four threads to prevent cylinder head from falling.

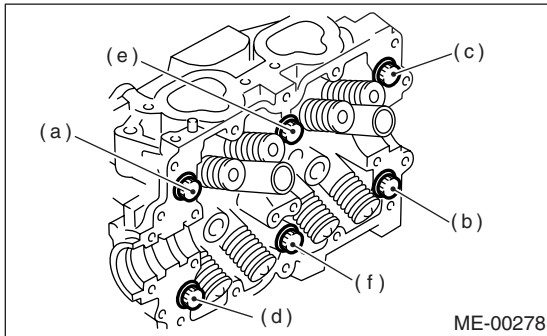

- 11) While tapping the cylinder head with a plastic hammer, separate it from cylinder block.
- 12) Remove the bolts (a) and (c) to remove cylinder head.

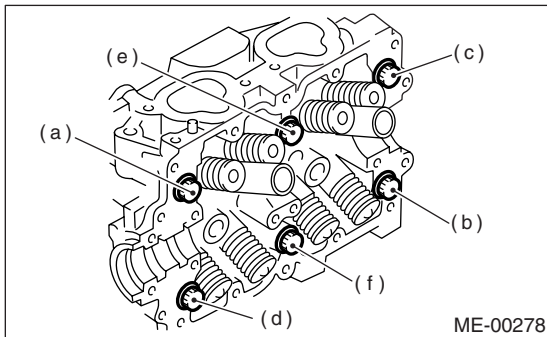

- 13) Remove the cylinder head gasket.

CAUTION:

Do not scratch the mating surface of cylinder head and cylinder block.

- 14) Similarly, remove the right side cylinder head.

B: INSTALLATION

- 1) Install the cylinder head and gaskets on cylinder block.

CAUTION:

- Use new cylinder head gaskets.
- Be careful not to scratch the mating surface of cylinder block and cylinder head.

- 2) Tighten the cylinder head bolts.
 - (1) Apply a coat of engine oil to washers and bolt threads.
 - (2) Tighten all bolts to 29 N·m (3.0 kgf·m, 22 ft·lb) in alphabetical sequence. Then tighten all bolts to 69 N·m (7.0 kgf·m, 51 ft·lb) in alphabetical sequence.
 - (3) Back off all bolts by 180° in reverse order of installation, and back them off again by 180°.
 - (4) Tighten all bolts to 42 N·m (3.9 kgf·m, 31 ft·lb) in alphabetical sequence.
 - (5) Tighten all bolts by 80° — 90° in alphabetical sequence.
 - (6) Tighten all bolts by 40° — 45° in alphabetical sequence.

NOTE:

Do not tighten the bolts more than 45°.

- (7) Further tighten bolts (a) and (b) by 40° — 45°.

NOTE:

Ensure the total “re-tightening angle” in the [former two steps], do not exceed 90°.

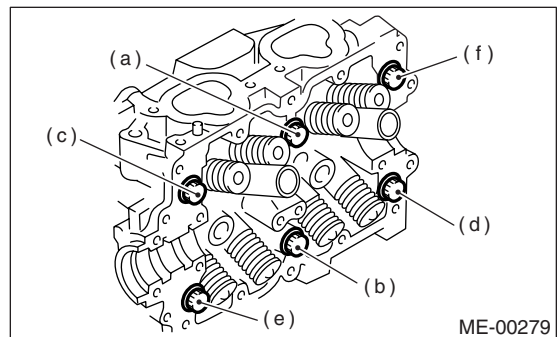

- 3) Install the camshaft. <Ref. to ME(H4SO)-59, INSTALLATION, Camshaft.>
- 4) Install the valve rocker assembly. <Ref. to ME(H4SO)-56, INSTALLATION, Valve Rocker Assembly.>
- 5) Install the A/C compressor bracket on cylinder head.
- 6) Install the intake manifold. <Ref. to FU(H4SO)-16, INSTALLATION, Intake Manifold.>

- 7) Install the cam sprocket. <Ref. to ME(H4SO)-53, INSTALLATION, Cam Sprocket.>
- 8) Install the timing belt assembly. <Ref. to ME(H4SO)-49, INSTALLATION, Timing Belt.>
- 9) Install the timing belt cover. <Ref. to ME(H4SO)-47, INSTALLATION, Timing Belt Cover.>
- 10) Install the crank pulley. <Ref. to ME(H4SO)-45, INSTALLATION, Crank Pulley.>
- 11) Install the V-belt. <Ref. to ME(H4SO)-43, INSTALLATION, V-belt.>

C: DISASSEMBLY

- 1) Place the cylinder head on ST.
ST 498267800 CYLINDER HEAD TABLE
- 2) Set the ST on valve spring. Compress the valve spring, and then remove the valve spring retainer key. Remove each valve and valve spring.
ST 499718000 VALVE SPRING REMOVER

CAUTION:

- Mark each valve to prevent confusion.
- Use extreme care not to damage the lips of intake valve oil seals and exhaust valve oil seals.

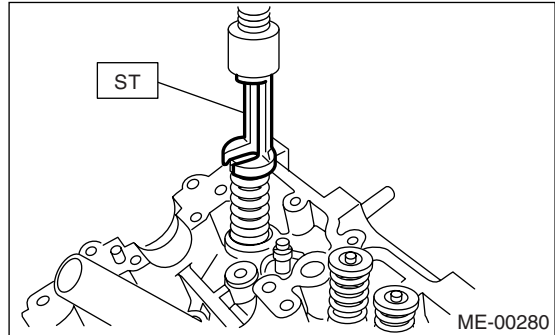

Cylinder Head

MECHANICAL

D: ASSEMBLY

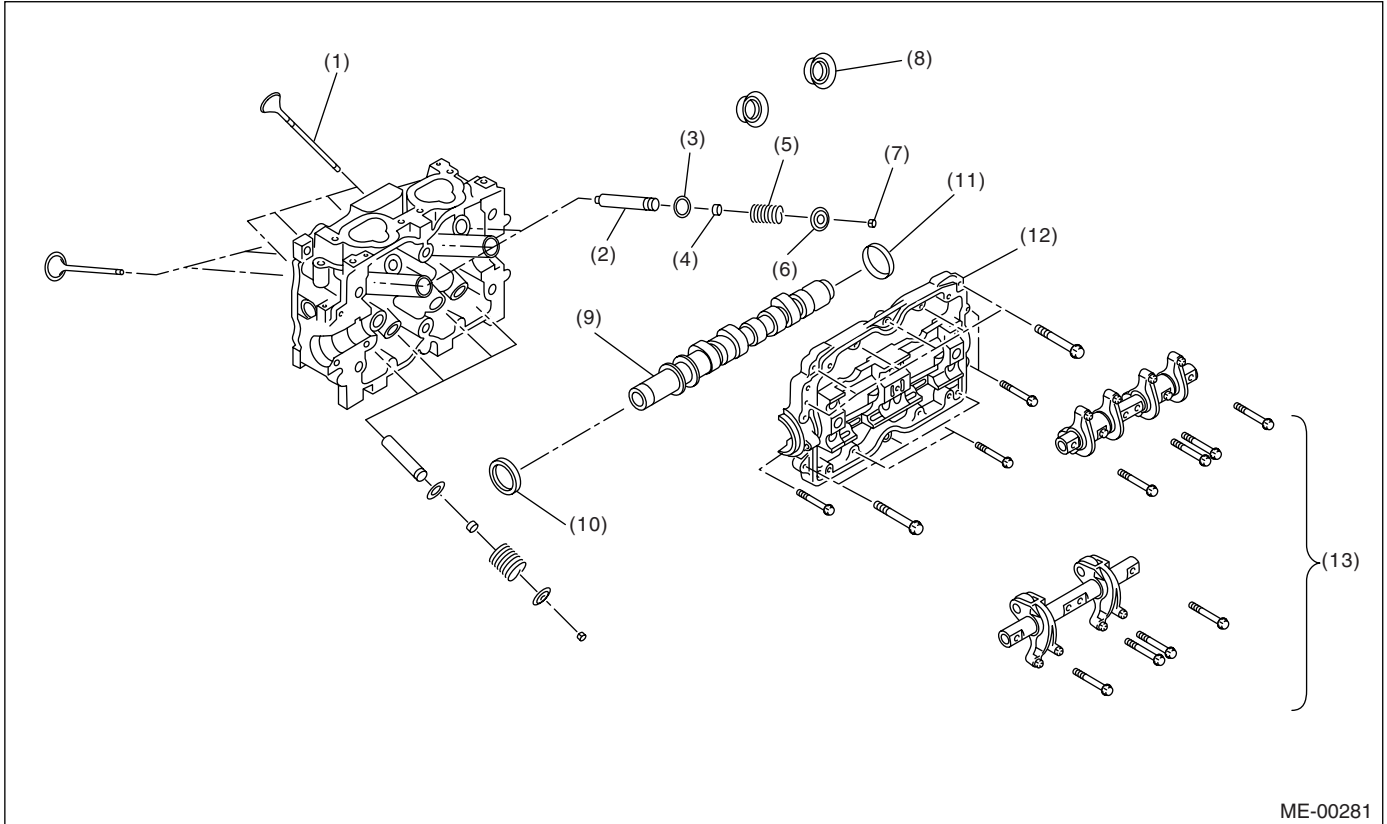

ME-00281

- | | | |
|-----------------------|-----------------------|------------------------|
| (1) Valve | (6) Retainer | (11) Plug |
| (2) Valve guide | (7) Retainer key | (12) Camshaft cap |
| (3) Valve spring seat | (8) Spark plug gasket | (13) Valve rocker ASSY |
| (4) Oil seal | (9) Camshaft | |
| (5) Valve spring | (10) Oil seal | |

- 1) Installation of valve spring and valve
 (1) Place the cylinder head on ST.
 ST 498267800 CYLINDER HEAD TABLE
 (2) Coat the stem of each valve with engine oil and insert valve into valve guide.

NOTE:
 When inserting the valve into valve guide, use special care not to damage the oil seal lip.

- (3) Install the valve spring and retainer.

NOTE:
 Be sure to install the valve springs with their close-coiled end facing the seat on the cylinder head.

- (4) Set the ST on valve spring.
 ST 499718000 VALVE SPRING REMOVER

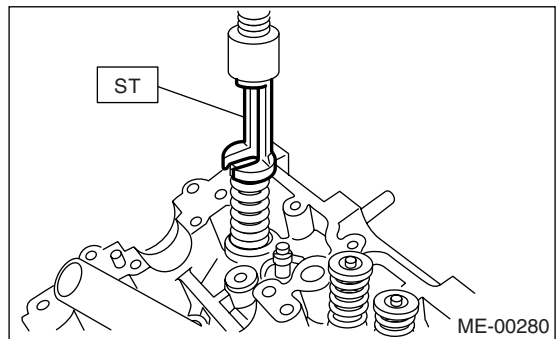

ME-00280

(5) Compress the valve spring, and then fit the valve spring retainer key.

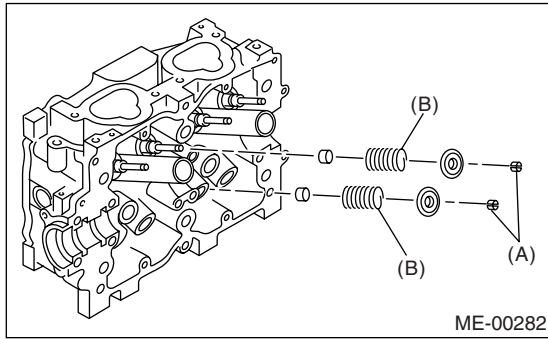

- (A) Retainer
- (B) Valve spring

(6) After installing, tap the valve spring retainers lightly with plastic hammer for better seating.

E: INSPECTION

1. VALVE SPRING

- 1) Check the valve springs for damage, free length, and tension. Replace the valve spring if it is not within the standard value presented in the table.
- 2) To measure the squareness of valve spring, stand the spring on a surface plate and measure its deflection at the top using a try square.

Free length	54.30 mm (2.1378 in)
Squareness	2.5°, 2.4 mm (0.094 in)
Tension/spring height	215 — 246 N (21.9 — 25.1 kgf, 48.2 — 55.3 lb)/ 45.0 mm (1.772 in)
	527 — 582 N (53.7 — 59.3 kgf, 118.1 — 130.8 lb)/ 34.7 mm (1.366 in)

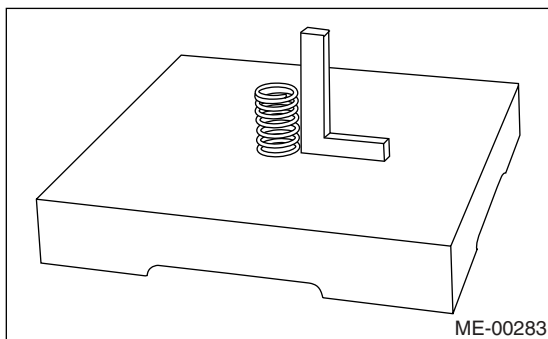

2. INTAKE AND EXHAUST VALVE OIL SEAL

In the following case, pinch and remove the oil seal from valve using pliers, and then replace it with a new one.

- When the lip is damaged.
- When the spring is out of the specified position.

- When readjusting the surfaces of intake valve and valve sheet.
- When replacing the intake valve guide.
 - 1) Place the cylinder head on ST1.
 - 2) Using ST2, press-fit the oil seal.

CAUTION:

- Apply engine oil to oil seal before press-fitting.
- When press-fitting oil seal, do not use hammer or strike in.
- Differentiate between intake valve oil seal and exhaust valve oil seal by noting their difference in color.

ST1 498267800 CYLINDER HEAD TABLE
ST2 498857100 VALVE OIL SEAL GUIDE

Color of rubber part:

Intake [Black]
Exhaust [Brown]

Color of spring part:

Intake [Silver]
Exhaust [Silver]

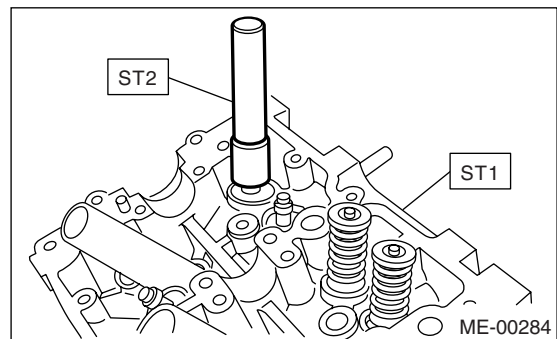

F: ADJUSTMENT

1. CYLINDER HEAD

- 1) Make sure that no crack or other damage exists. In addition to visual inspection, inspect important areas by means of red lead check. Also make sure that gasket installing surface shows no trace of gas and water leaks.
 - 2) Place the cylinder head on ST.
- ST 498267800 CYLINDER HEAD TABLE
- 3) Measure the warping of the cylinder head surface that mates with crankcase using a straight edge and thickness gauge. If the warping exceeds the limit, regrind the surface with a surface grinder.

Warping limit:

0.05 mm (0.0020 in)

Grinding limit:

0.1 mm (0.004 in)

Standard height of cylinder head:

97.5 mm (3.839 in)

Cylinder Head

MECHANICAL

NOTE:

Uneven torque for the cylinder head bolts can cause warping. When reassembling, pay special attention to the torque so as to tighten evenly.

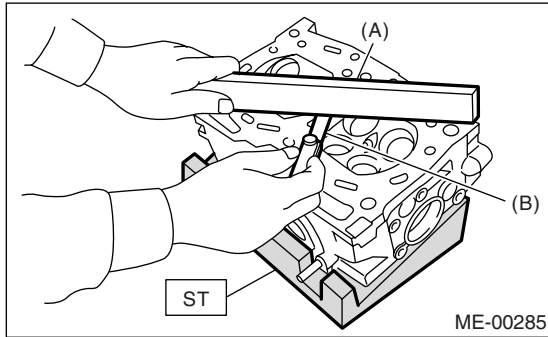

- (A) Straight edge
- (B) Thickness gauge

2. VALVE SEAT

Inspect the intake and exhaust valve seats, and then correct the contact surfaces with valve seat cutter if they are defective or when valve guides are replaced.

Valve seat width: *W*

Intake (A)

Standard 1.1 mm (0.043 in)

Limit 1.8 mm (0.071 in)

Exhaust (B)

Standard 1.5 mm (0.059 in)

Limit 2.2 mm (0.087 in)

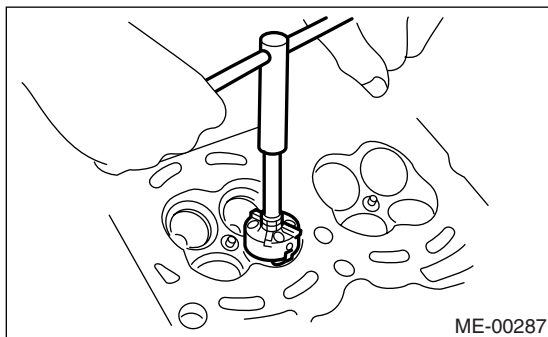
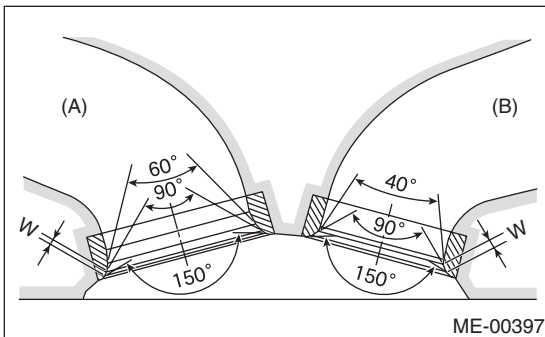

3. VALVE GUIDE

1) Check the clearance between valve guide and stem. The clearance can be checked by measuring the outside diameter of valve stem and the inside diameter of valve guide with outside and inside micrometers respectively.

Clearance between the valve guide and valve stem:

Standard

Intake 0.035 — 0.062 mm (0.0014 — 0.0024 in)

Exhaust 0.040 — 0.067 mm (0.0016 — 0.0026 in)

Limit

0.15 mm (0.0059 in)

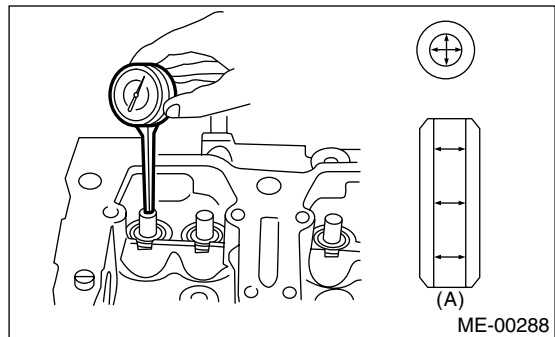

(A) Valve guide

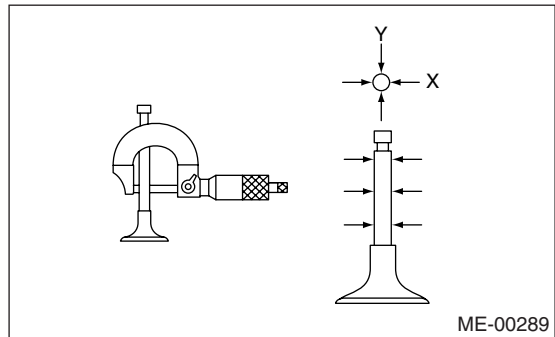

2) If the clearance between valve guide and stem exceeds the standard value, replace the valve guide or valve itself whichever shows greater amount of wear. See the following procedure for valve guide replacement.

Valve guide inner diameter:

6.000 — 6.012 mm (0.2362 — 0.2367 in)

Valve stem outer diameters:

Intake

5.950 — 5.965 mm (0.2343 — 0.2348 in)

Exhaust

5.945 — 5.960 mm (0.2341 — 0.2346 in)

(1) Place the cylinder head on ST1 with the combustion chamber upward so that valve guides enter the holes in ST1.

(2) Insert the ST2 into valve guide and press it down to remove valve guide.

ST1 498267800 CYLINDER HEAD TABLE
ST2 499767200 VALVE GUIDE REMOVER

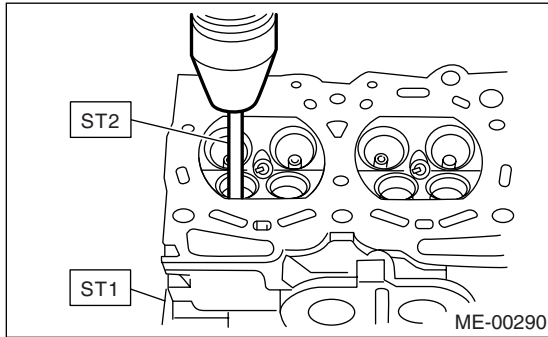

(3) Turn the cylinder head upside down and place ST as shown in the figure.

Intake side:
ST 499767700 VALVE GUIDE ADJUSTER
Exhaust side:
ST 499767800 VALVE GUIDE ADJUSTER

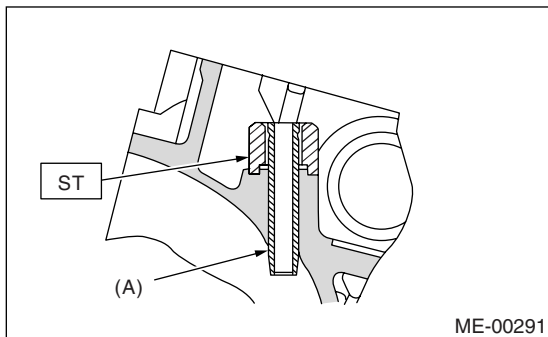

(A) Valve guide

(4) Before installing new oversize valve guide, make sure that neither scratches nor damages exist on the inside surface of valve guide holes in cylinder head.

(5) Put new valve guide, coated with sufficient oil, in the cylinder, and then insert the ST1 into valve guide. Press in until the valve guide upper end is flush with the upper surface of ST2.

ST1 499767200 VALVE GUIDE REMOVER
Intake side:
ST2 499767700 VALVE GUIDE ADJUSTER
Exhaust side:
ST2 499767800 VALVE GUIDE ADJUSTER

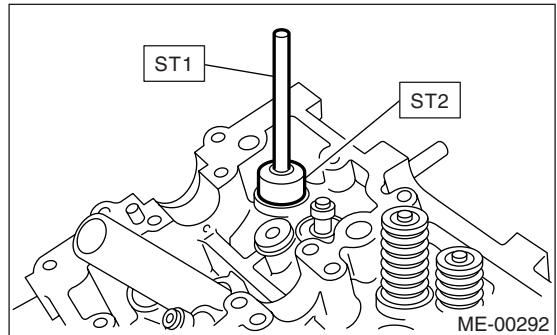

(6) Check the valve guide protrusion.

Valve guide protrusion: L

Intake

20.0 — 20.5 mm (0.787 — 0.807 in)

Exhaust

16.5 — 17.0 mm (0.650 — 0.669 in)

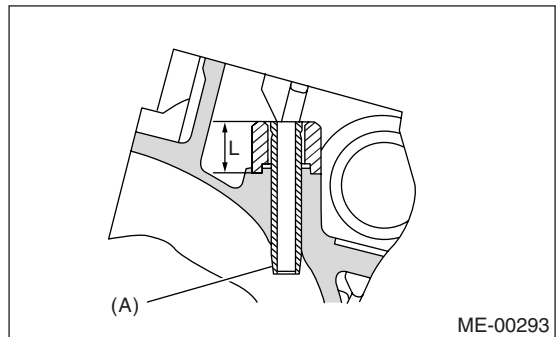

(A) Valve guide

(7) Ream the inside of valve guide with ST. Gently rotate the reamer clockwise while pressing it lightly into valve guide, and return it also rotating clockwise. After reaming, clean the valve guide to remove chips.

CAUTION:

- Apply engine oil to the reamer when reaming.
- If the inner surface of the valve guide is torn, the edge of the reamer should be slightly ground with an oil stone.
- If the inner surface of the valve guide becomes lustrous and the reamer does not chips, use a new reamer or remedy the reamer.

Cylinder Head

MECHANICAL

ST 499767400 VALVE GUIDE REAMER

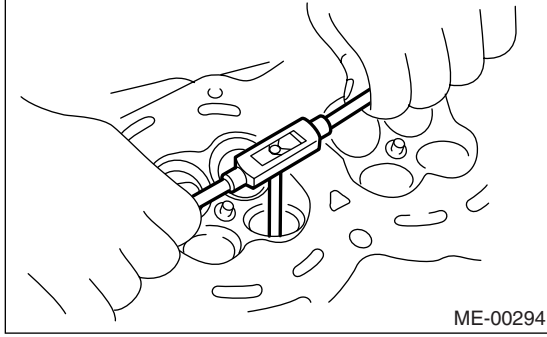

(8) Recheck the contact condition between valve and valve seat after replacing valve guide.

4. INTAKE AND EXHAUST VALVE

1) Inspect the flange and stem of valve, and replace if damaged, worn, or deformed, or if "H" is less than the specified limit.

H:

Intake

Standard 1.0 mm (0.039 in)

Limit 0.6 mm (0.024 in)

Exhaust

Standard 1.2 mm (0.047 in)

Limit 0.6 mm (0.024 in)

Valve overall length:

Intake

120.6 mm (4.75 in)

Exhaust

121.7 mm (4.79 in)

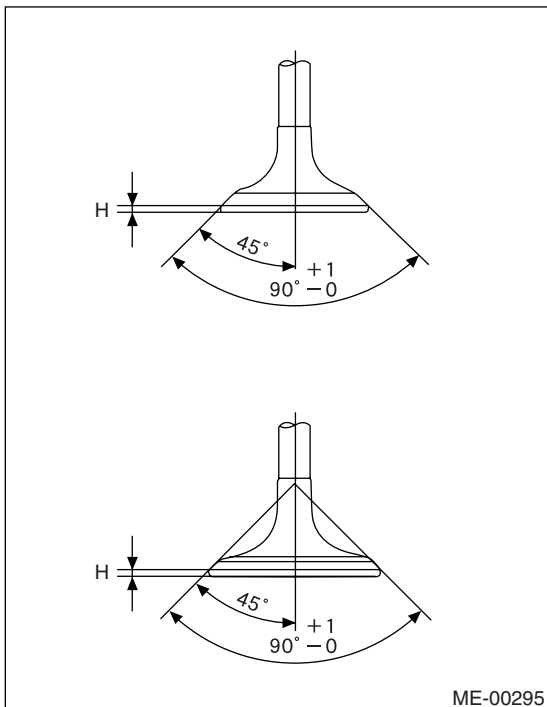

2) Put a small amount of grinding compound on the seat surface and lap the valve and seat surface. <Ref. to ME(H4SO)-66, VALVE SEAT, ADJUSTMENT, Cylinder Head.> Install a new intake valve oil seal after lapping.

21. Cylinder Block

A: REMOVAL

NOTE:

Before conducting this procedure, drain the engine oil completely.

- 1) Remove the intake manifold. <Ref. to FU(H4SO)-14, REMOVAL, Intake Manifold.>
- 2) Remove the V-belt. <Ref. to ME(H4SO)-43, REMOVAL, V-belt.>
- 3) Remove the crank pulley. <Ref. to ME(H4SO)-45, REMOVAL, Crank Pulley.>
- 4) Remove the timing belt cover. <Ref. to ME(H4SO)-47, REMOVAL, Timing Belt Cover.>
- 5) Remove the timing belt. <Ref. to ME(H4SO)-48, REMOVAL, Timing Belt.>
- 6) Remove the cam sprocket. <Ref. to ME(H4SO)-53, REMOVAL, Cam Sprocket.>
- 7) Remove the crank sprocket. <Ref. to ME(H4SO)-45, REMOVAL, Crank Pulley.>
- 8) Remove the generator and A/C compressor with their brackets.
- 9) Remove the rocker cover.
- 10) Remove the cylinder head bolts in alphabetical sequence shown in the figure.

NOTE:

Leave bolts (a) and (c) engaged by three or four threads to prevent cylinder head from falling.

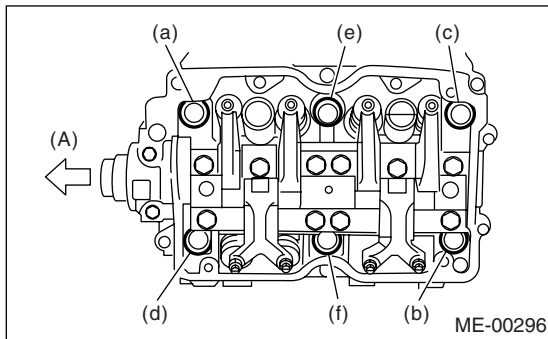

(A) Front

- 11) While tapping the cylinder head with a plastic hammer, separate it from cylinder block.

- 12) Remove the bolts (a) and (c) to remove cylinder head.

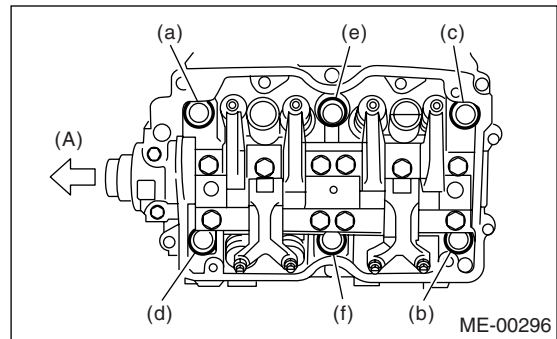

(A) Front

- 13) Remove the cylinder head gasket.

NOTE:

Do not scratch the mating surface of cylinder head and cylinder block.

- 14) Similarly, remove the right side cylinder head.
- 15) Remove the clutch housing cover. (MT model)
- 16) Remove the flywheel (MT model) or drive plate (AT model).

Using the ST, lock the crankshaft.

ST 498497100 CRANKSHAFT STOPPER

- MT model

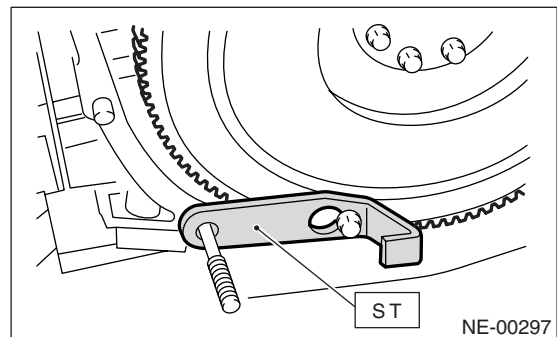

- AT model

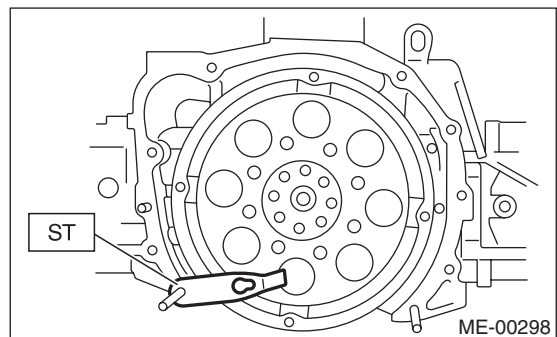

Cylinder Block

MECHANICAL

NOTE:

Using STs, remove the flywheel. (2.5 L MT model)

ST1 498497100 CRANKSHAFT STOPPER

ST2 499057000 TORX PLUS

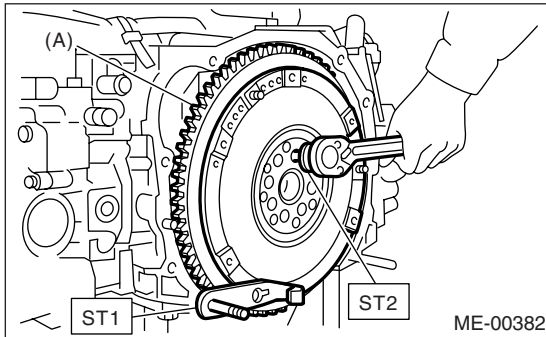

(A) Flywheel

- 17) Remove the oil separator cover.
- 18) Remove the water by-pass pipe for heater.
- 19) Loosen the bolts in alphabetical sequence as shown in the figure, and then remove water pump.

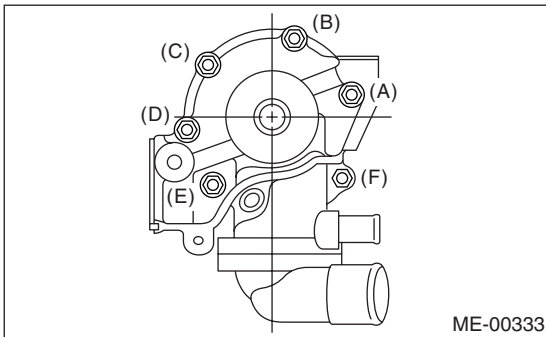

- 20) Remove the oil pump from cylinder block. Use a flat-tip screwdriver as shown in the figure when removing the oil pump.

NOTE:

Be careful not to scratch the mating surface of cylinder block and oil pump.

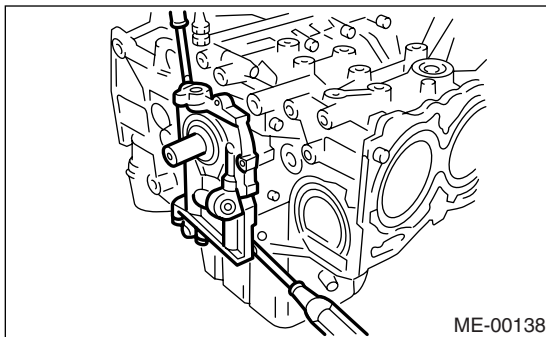

21) Removal of oil pan

- (1) Turn the cylinder block to face the #2 and #4 piston sides upward.
- (2) Remove the bolts which secure oil pan to cylinder block.

- (3) Insert a oil pan cutter blade between cylinder block-to-oil pan clearance, and then remove the oil pan.

NOTE:

Do not use a screwdriver or similar tool in place of oil pan cutter.

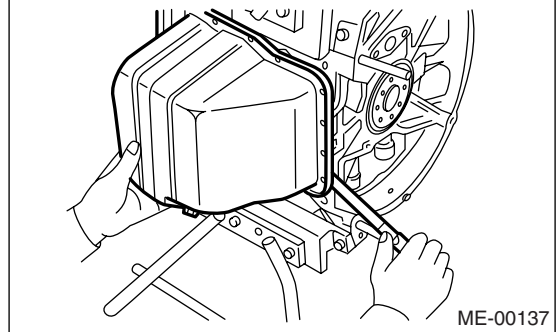

- 22) Remove the oil strainer stay.
 - 23) Remove the oil strainer.
 - 24) Remove the baffle plate.
 - 25) Remove the oil filter using ST.
- ST 498547000 OIL FILTER WRENCH

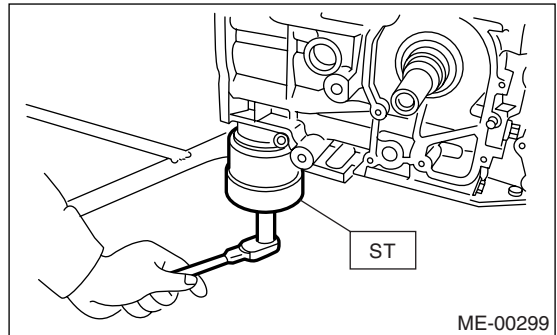

Cylinder Block

MECHANICAL

26) Remove the water pipe.

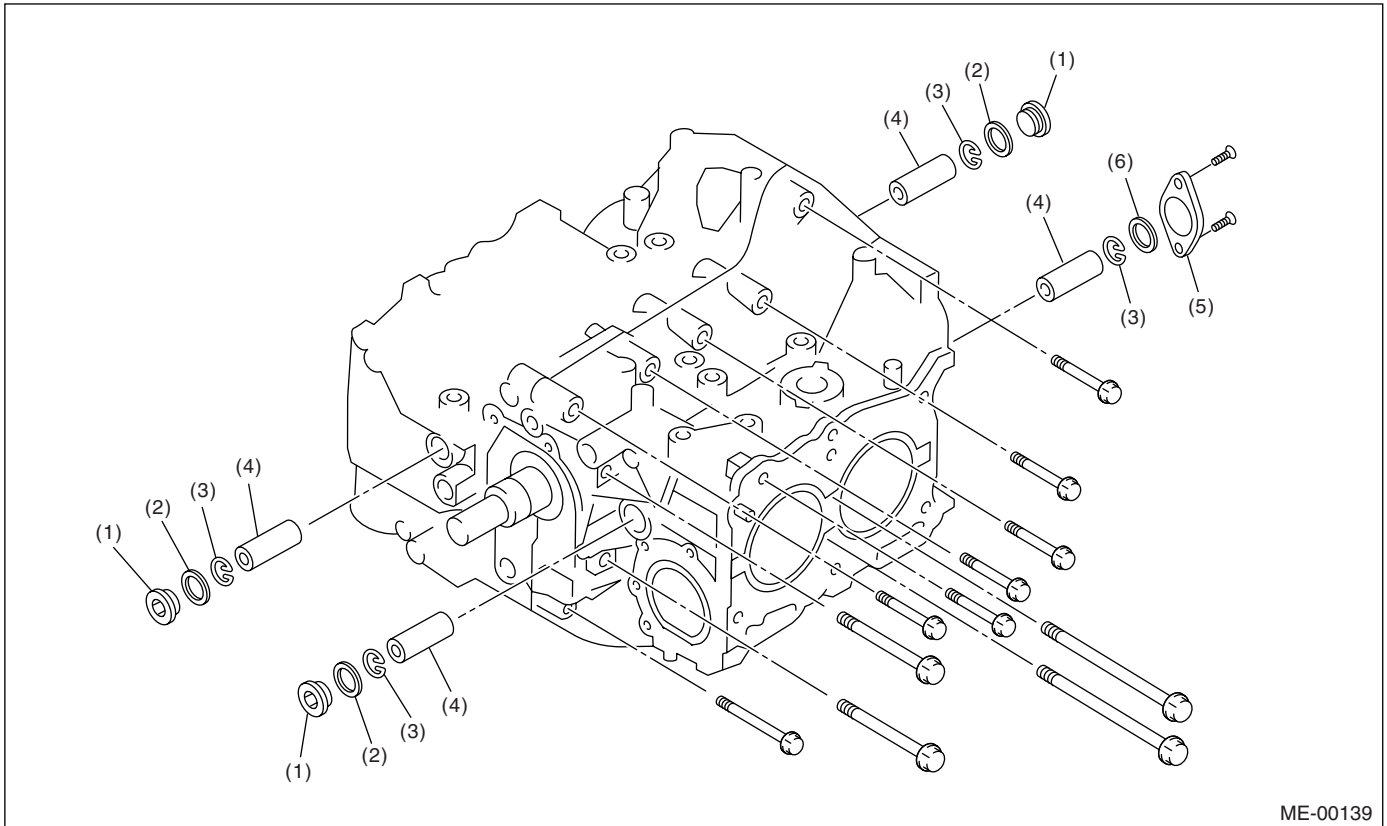
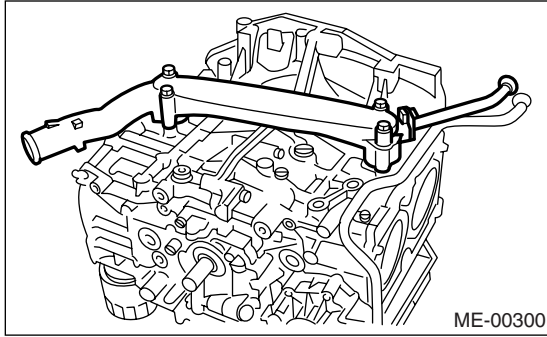

(1) Service hole plug

(2) Gasket

(3) Snap ring

(4) Piston pin

(5) Service hole cover

(6) O-ring

27) Remove the service hole cover and service hole plugs using hexagon wrench [14 mm (0.55 in)].

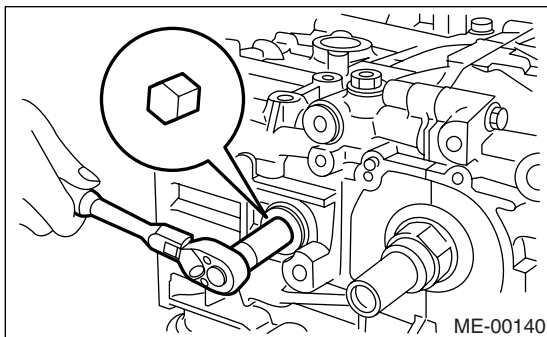

28) Rotate the crankshaft to bring #1 and #2 pistons to bottom dead center position, and then remove the piston snap ring through service hole of #1 and #2 cylinders using needle nose plier.

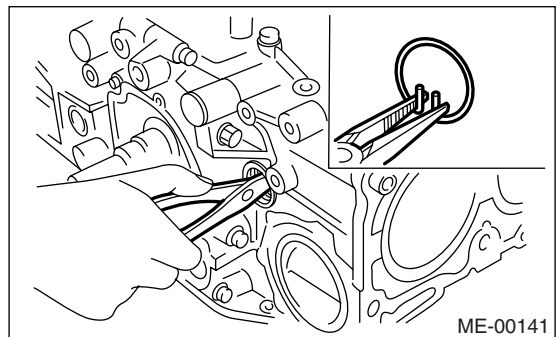

Cylinder Block

MECHANICAL

29) Draw out the piston pin from #1 and #2 pistons using ST.

ST 499097700 PISTON PIN REMOVER

NOTE:

Be careful not to confuse the original combination of piston, piston pin and cylinder.

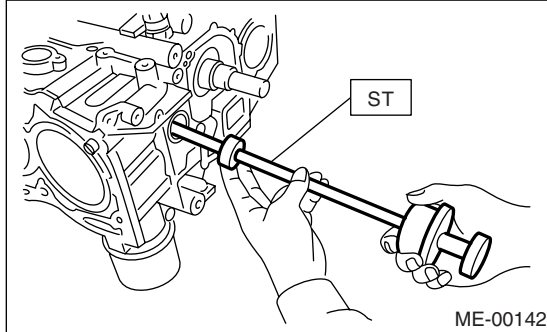

30) Similarly remove the piston pins from #3 and #4 pistons.

31) Remove the bolts which connect cylinder block on the side of #2 and #4 cylinders.

32) Back off the bolts which connect cylinder block on the side of #1 and #3 cylinders two or three turns.

33) Set up the cylinder block so that #1 and #3 cylinders are on the upper side, and then remove the cylinder block connecting bolts.

34) Separate the cylinder blocks (RH) and (LH).

NOTE:

When separating the cylinder block, do not allow the connecting rod to fall and damage the cylinder block.

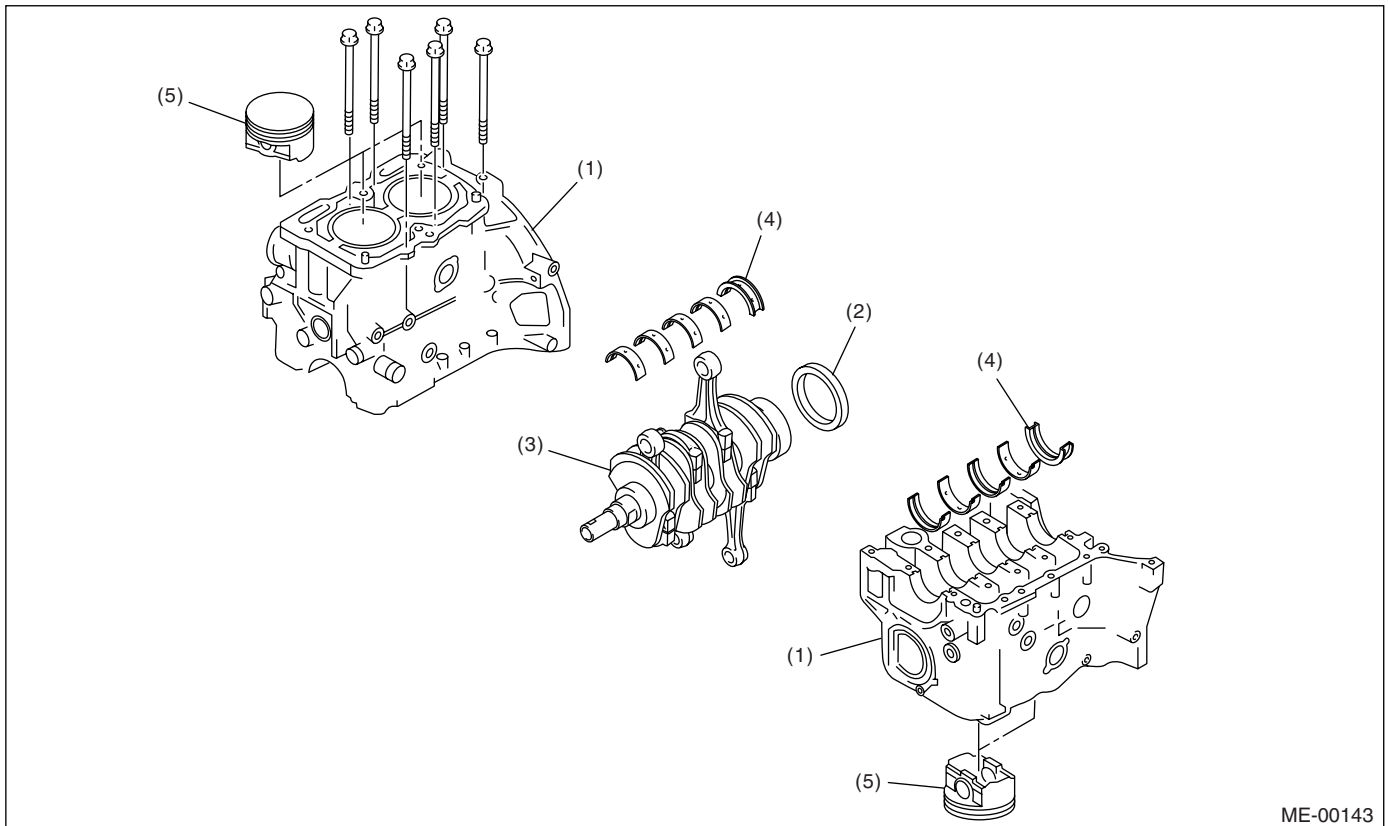

(1) Cylinder block

(3) Crankshaft

(5) Piston

(2) Rear oil seal

(4) Crankshaft bearing

35) Remove the rear oil seal.

36) Remove the crankshaft together with connecting rod.

37) Remove the crankshaft bearings from cylinder block using hammer handle.

NOTE:

Do not confuse the combination of crankshaft bearings. Press bearing at the end opposite to locking lip.

38) Draw out each piston from cylinder block using wooden bar or hammer handle.

NOTE:

Do not confuse the combination of piston and cylinder.

B: INSTALLATION

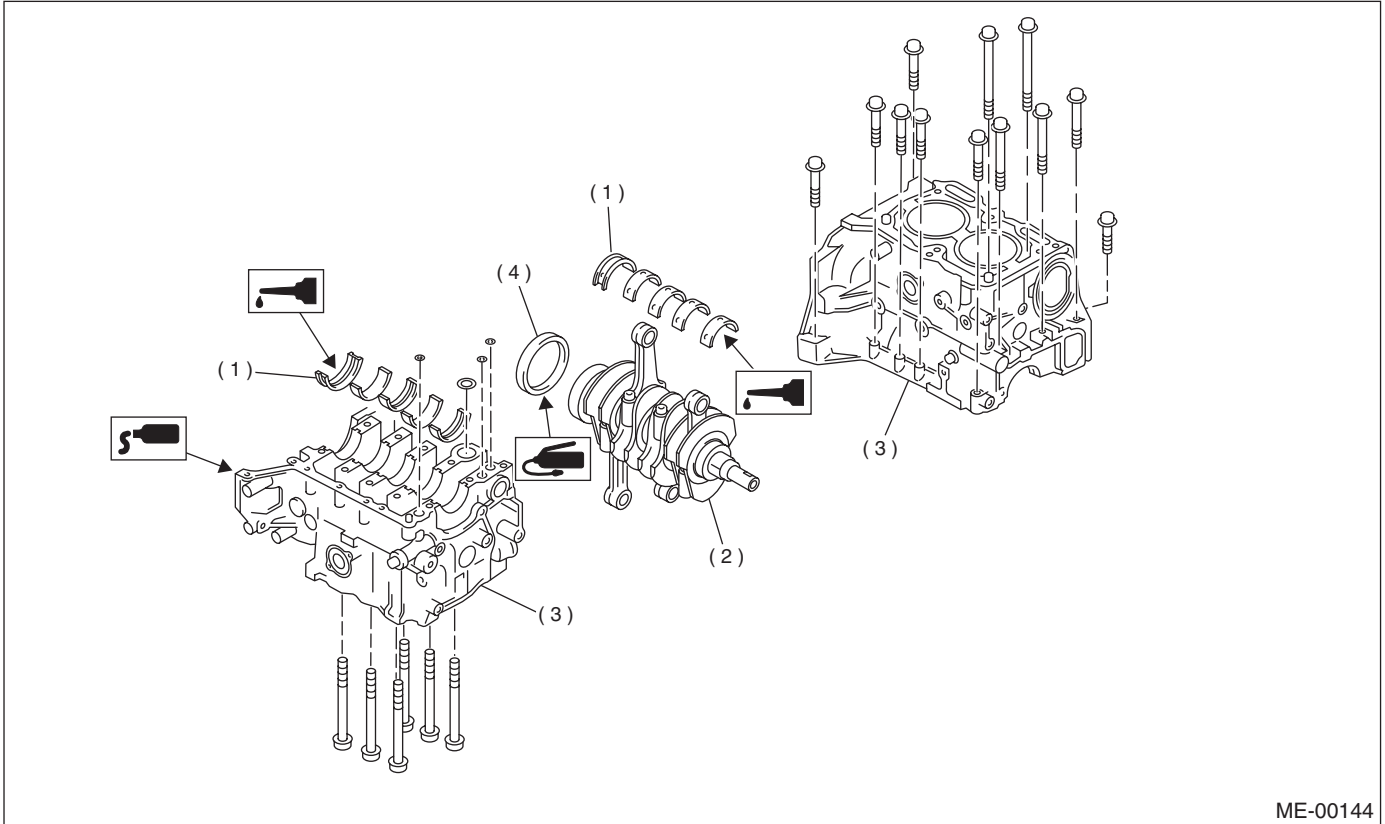

ME-00144

- (1) Crankshaft bearing
- (2) Crankshaft

- (3) Cylinder block

- (4) Rear oil seal

NOTE:

Remove oil in the mating surface of bearing and cylinder block before installation. Also apply a coat of engine oil to crankshaft pins.

- 1) Position the crankshaft on #2 and #4 cylinder block.
- 2) Apply liquid gasket to the mating surface of #1 and #3 cylinder block, and position it on #2 and #4 cylinder block.

Liquid gasket:

THREE BOND 1215 (Part No. 004403007) or equivalent

NOTE:

Do not allow liquid gasket to jut into O-ring grooves, oil passages, bearing grooves, etc.

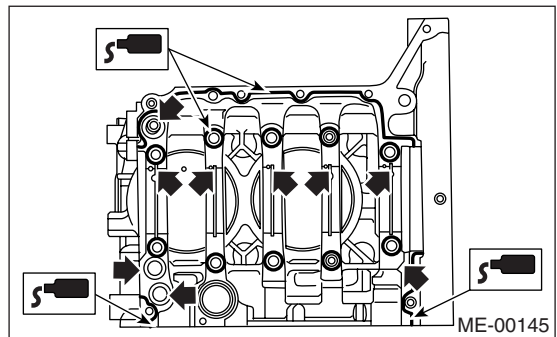

- 3) Apply engine oil to washers and bolt threads.

Cylinder Block

MECHANICAL

4) Tighten the 10 mm cylinder block connecting bolts on LH side (A — D) in alphabetical sequence.

Tightening torque:

15 N·m (1.5 kgf·m, 10.8 ft·lb)

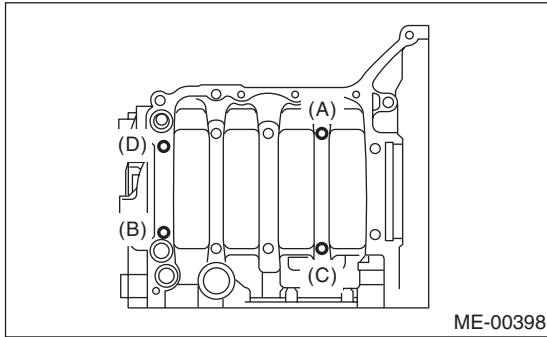

5) Tighten the 10 mm cylinder block connecting bolts on RH side (E — J) in alphabetical sequence.

Tightening torque:

15 N·m (1.5 kgf·m, 10.8 ft·lb)

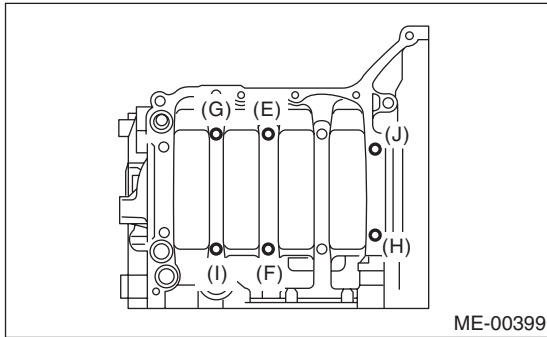

6) Further tighten the LH side bolts (A — D) to 90° in alphabetical sequence.

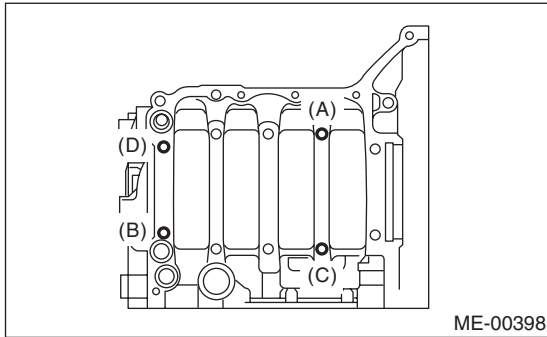

7) Further tighten the RH side bolts (E — J) to 90° in alphabetical sequence.

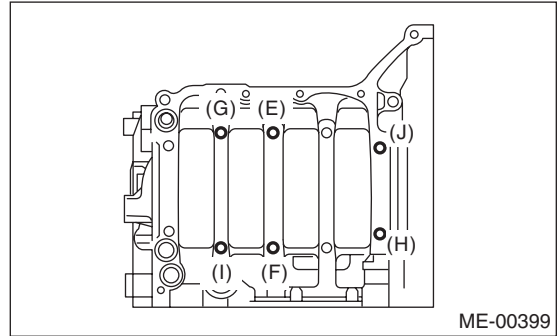

8) Tighten the 8 mm and 6 mm cylinder block connecting bolts on LH side (A — H) in alphabetical sequence.

Tightening torque:

(A) — (G): 25 N·m (2.5 kgf·m, 18.1 ft·lb)

(H): 6.4 N·m (0.65 kgf·m, 4.7 ft·lb)

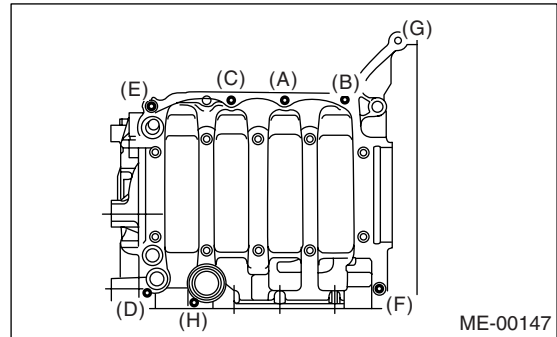

9) Install the rear oil seal using ST1 and ST2.
 ST1 499597100 OIL SEAL GUIDE
 ST2 499587200 OIL SEAL INSTALLER

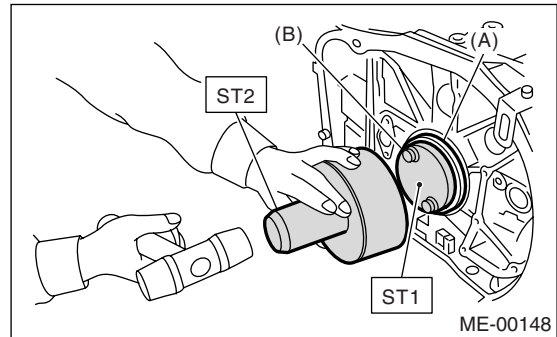

(A) Rear oil seal

(B) Fly wheel attaching bolt

10) Position the top ring gap at (A) or (B) in the figure.

11) Position the second ring gap at 180° on the reverse side for top ring gap.

- 2.0 L model

Cylinder Block

MECHANICAL

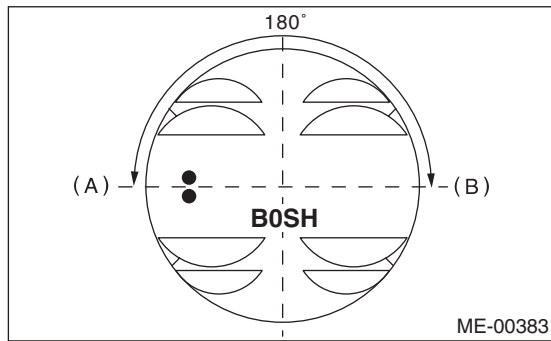

- 2.5 L model

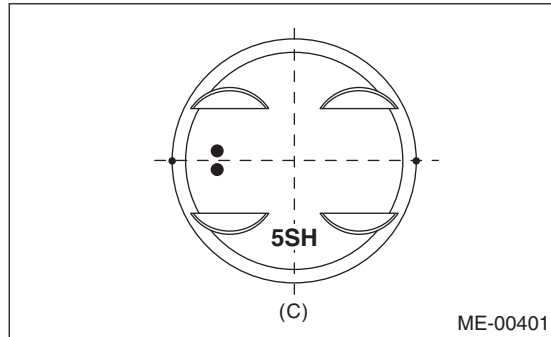

12) Position the expander gap at (C) in the figure.

- 2.0 L model

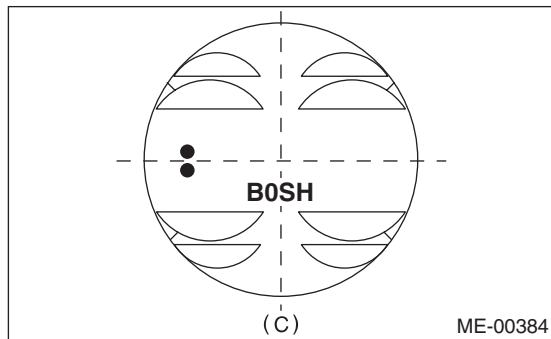

- 2.5 L model

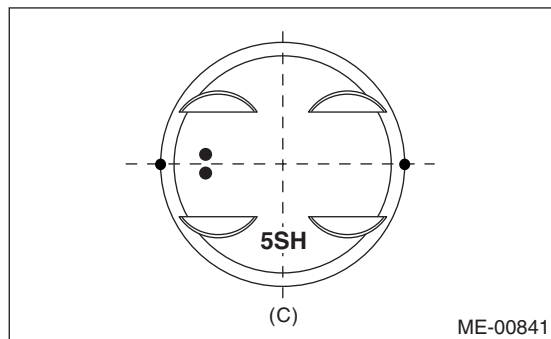

13) Position the lower rail gap at (D) in the figure.

- 2.0 L model

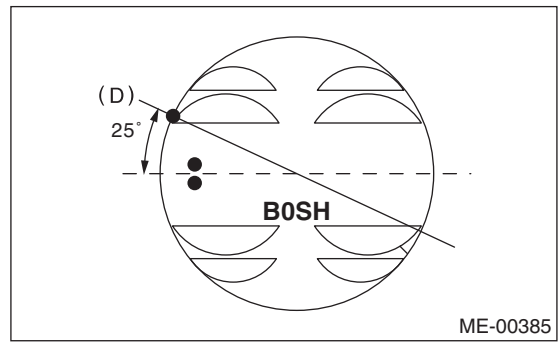

- 2.5 L model

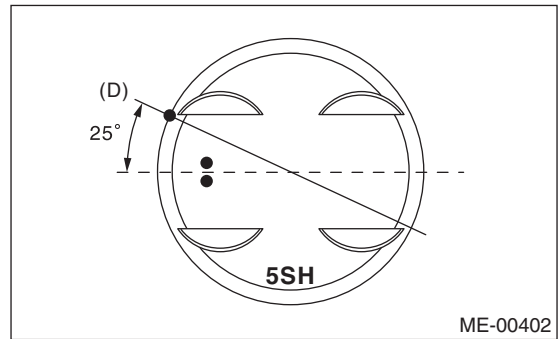

NOTE:

Align the lower rail stopper (F) to the lateral hole (E) on the piston.

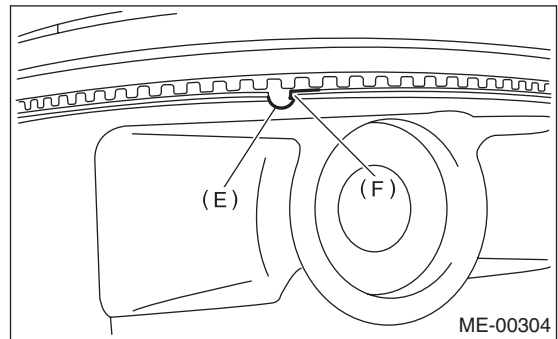

14) Position the upper rail gap at (G) in the figure.

- 2.0 L model

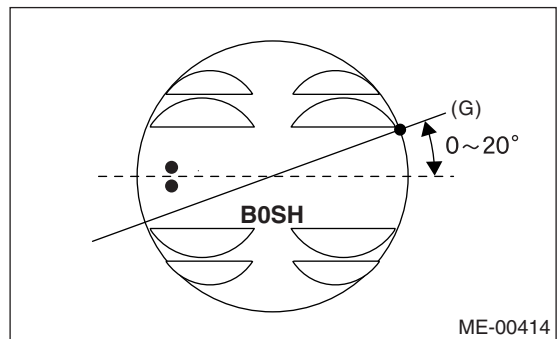

Cylinder Block

MECHANICAL

- 2.5 L model

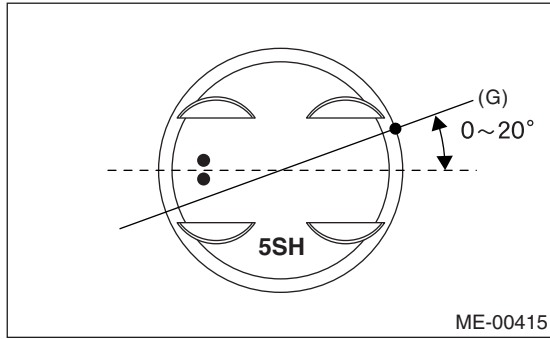

- 2.5 L model

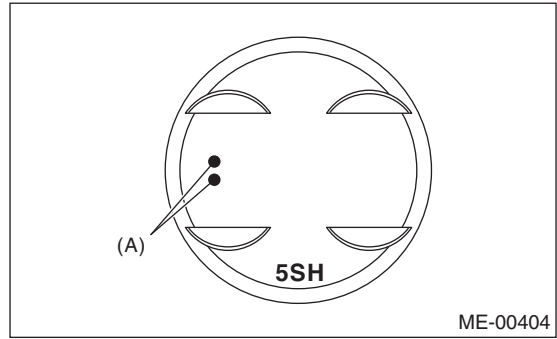

CAUTION:

- Ensure ring gaps do not face the same direction.
- Ensure ring gaps are not within the piston skirt area.

15) Install snap ring.

Install snap rings in the piston holes located opposite service holes in cylinder block, when positioning all pistons in the corresponding cylinders.

NOTE:

Use new snap rings.

(A) Front mark

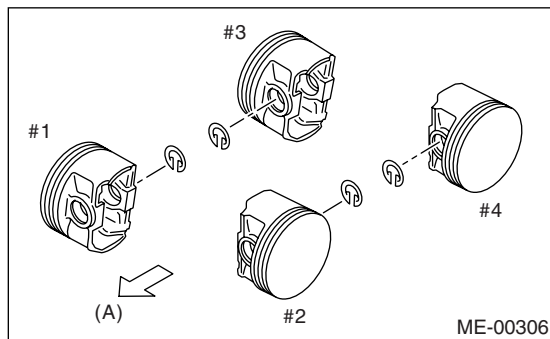

(A) Front side

CAUTION:

Piston front mark faces towards the front of the engine.

- 2.0 L model

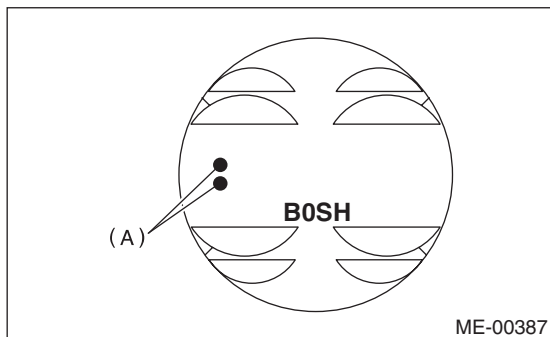

Cylinder Block

MECHANICAL

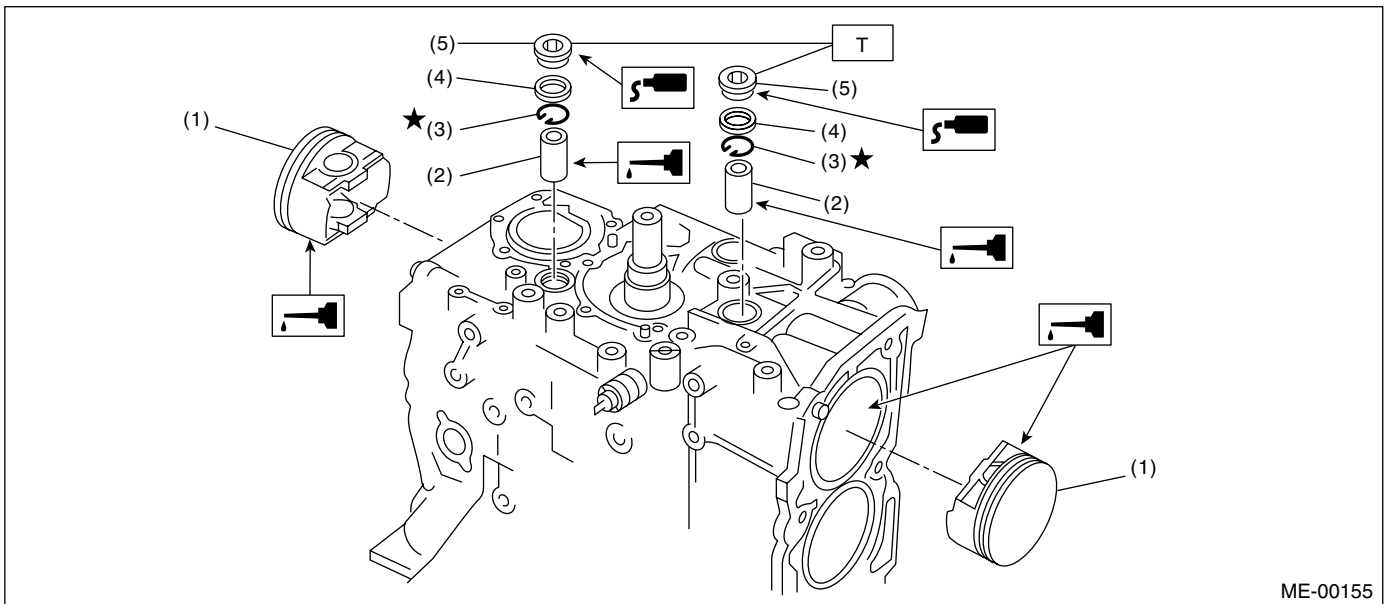

ME-00155

- | | |
|----------------|-----------------------|
| (1) Piston | (4) Gasket |
| (2) Piston pin | (5) Service hole plug |
| (3) Circlip | |

Tightening torque: N-m (kgf-m, ft-lb)
T: 70 (7.0, 50.6)

16) Installing piston

- (1) Turn the cylinder block to face the #1 and #2 piston side upward.
- (2) Using the ST1, turn the crankshaft so that #1 and #2 connecting rods are set at bottom dead center.

ST1 499987500 CRANKSHAFT SOCKET

- (3) Apply a coat of engine oil to pistons and cylinders, and then insert the pistons in their cylinders using ST2.

- ST2 398744300 PISTON GUIDE (2.0 L model)
 ST2 498747300 PISTON GUIDE (2.5 L model)

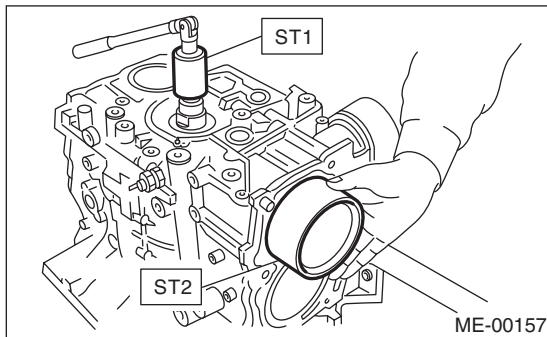

ME-00157

17) Installing piston pin

- (1) Apply a coat of engine oil to the ST3 before insertion.
- (2) Insert the ST3 into service hole to align piston pin hole with connecting rod small end.

ST3 499017100 PISTON PIN GUIDE

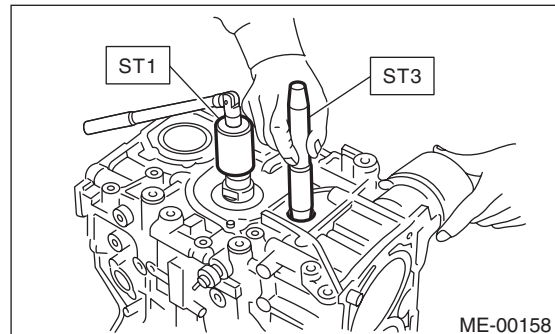

ME-00158

- (3) Apply a coat of engine oil to the piston pin, and then insert the piston pin into piston and connecting rod through service hole.
- (4) Install the snap ring using needle nose plier.

NOTE:
 Use new snap rings.

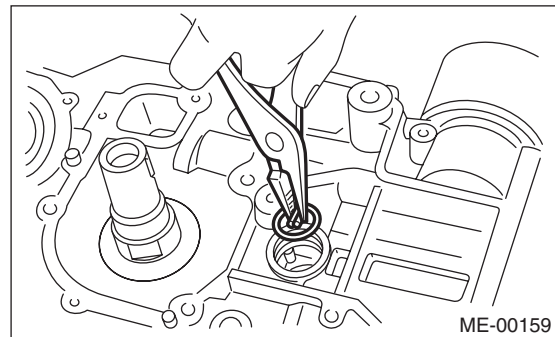

ME-00159

Cylinder Block

MECHANICAL

(5) Apply liquid gasket around the service hole plug.

(6) Install the service hole plug and gasket.

Liquid gasket:

THREE BOND 1215 (Part No. 004403007) or equivalent

NOTE:

Use a new gasket.

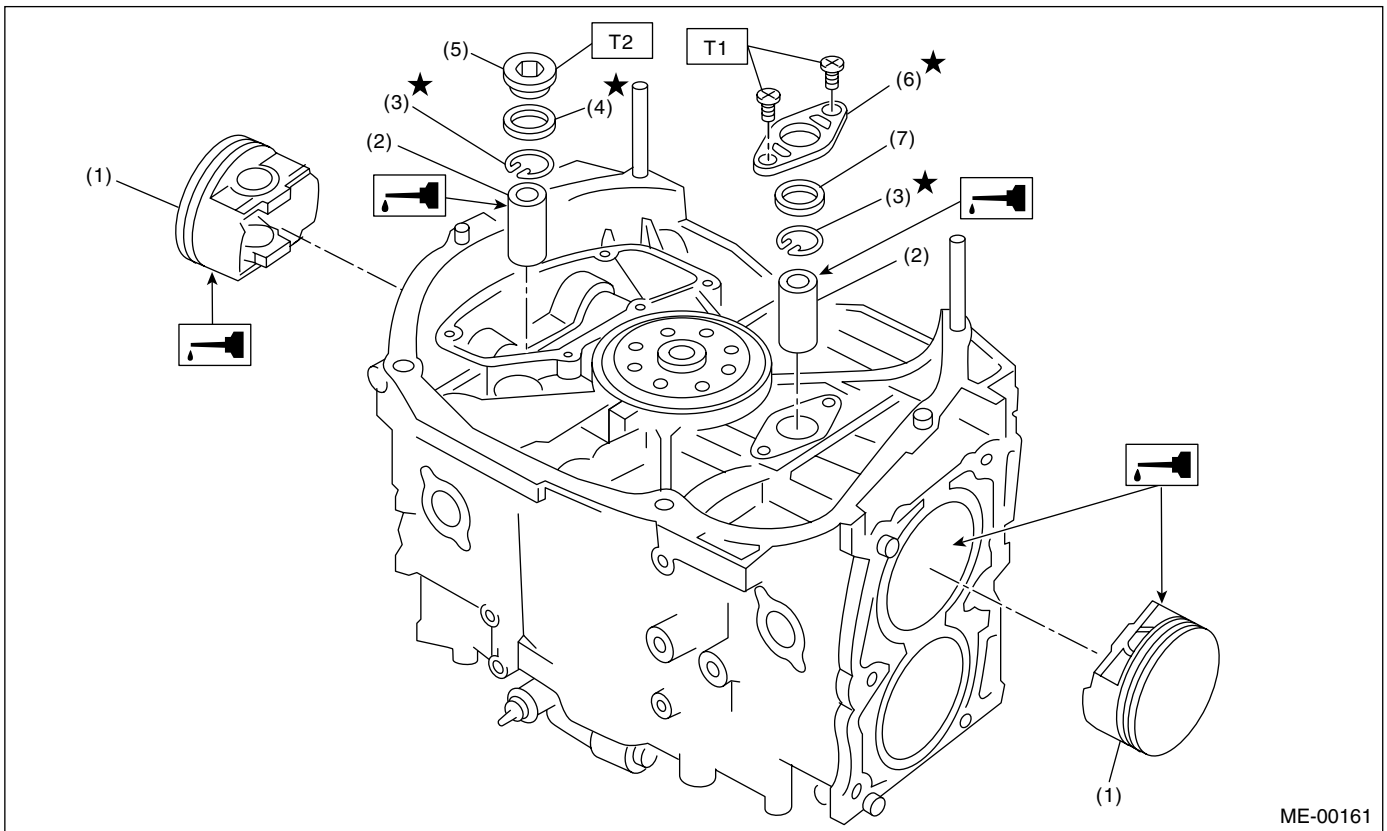
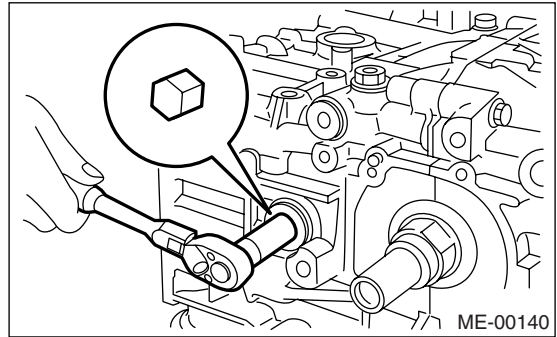
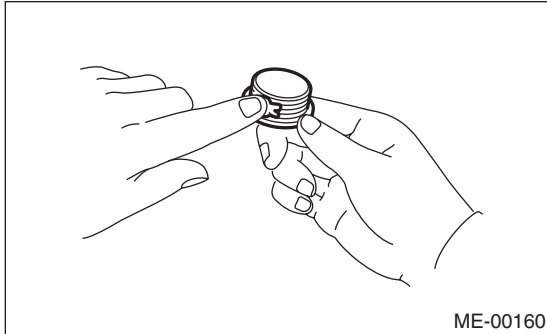

- | | |
|----------------|------------------------|
| (1) Piston | (5) Service hole plug |
| (2) Piston pin | (6) Service hole cover |
| (3) Snap ring | (7) O-ring |
| (4) Gasket | |

Tightening torque: N·m (kgf·m, ft·lb)

T1: 6.4 (0.65, 4.7)

T2: 70 (7.1, 51.4)

(7) Turn the cylinder block to face the #3 and #4 piston side upward. Using the same procedures as used for #1 and #2 cylinders, install the pistons and piston pins.

18) Install the water pipe.

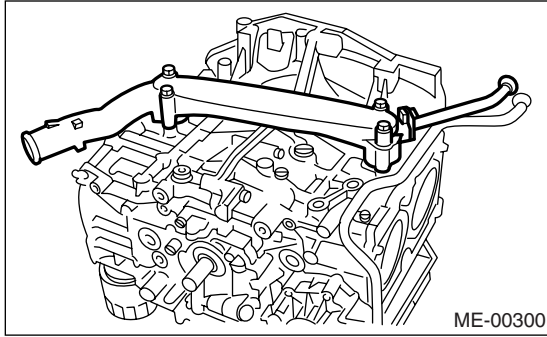

19) Install the baffle plate.

Tightening torque:

6.4 N·m (0.65 kgf-m, 4.7 ft-lb)

20) Install the oil strainer and O-ring.

Tightening torque:

10 N·m (1.0 kgf-m, 7 ft-lb)

21) Install the oil strainer stay.

22) Apply liquid gasket to the matching surfaces, and then install the oil pan.

Liquid gasket:

THREE BOND 1215 (Part No. 004403007) or equivalent

Tightening torque:

6.4 N·m (0.65 kgf-m, 4.7 ft-lb)

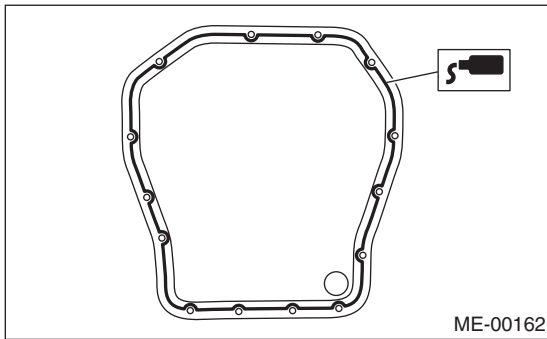

23) Apply liquid gasket to the matching surfaces, and then install the oil separator cover.

Liquid gasket:

THREE BOND 1215 (Part No. 004403007) or equivalent

Tightening torque:

6.4 N·m (0.65 kgf-m, 4.7 ft-lb)

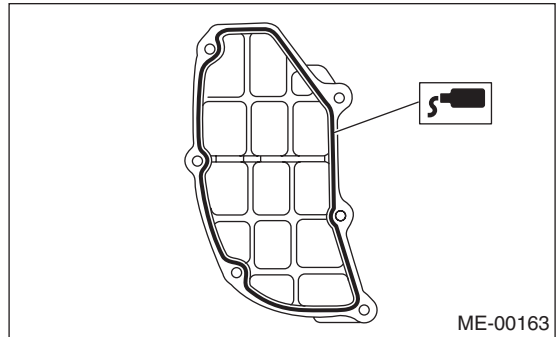

24) Install the flywheel or drive plate.

To lock the crankshaft, use ST.

ST 498497100 CRANKSHAFT STOPPER

Tightening torque:

72 N·m (7.3 kgf-m, 52.8 ft-lb)

- MT model

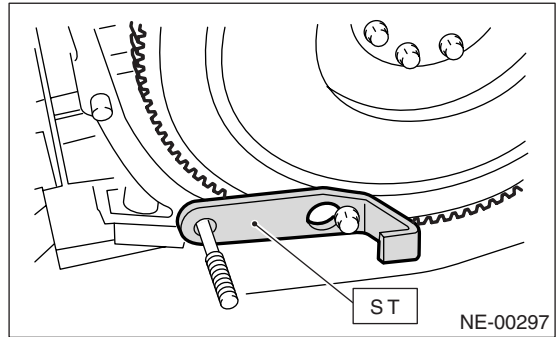

- AT model

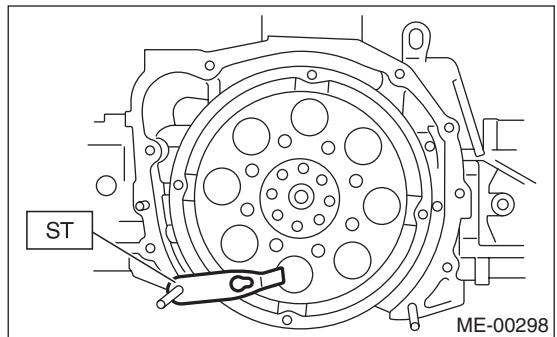

NOTE:

Using STs, remove the flywheel. (2.5 L MT model)

ST1 498497100 CRANKSHAFT STOPPER

Cylinder Block

MECHANICAL

ST2 499057000 TORX PLUS

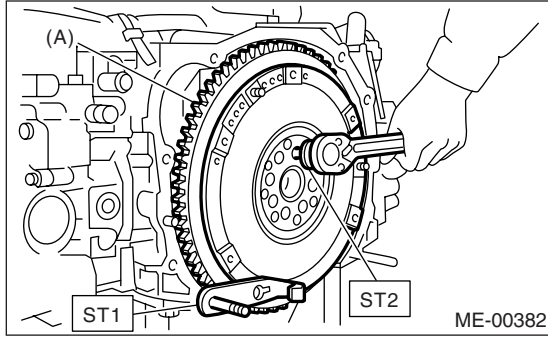

(A) Flywheel

25) Install the housing cover.

26) Installation of oil pump

(1) Discard the front oil seal after removal. Replace with a new one using the ST.

ST 499587100 OIL SEAL INSTALLER

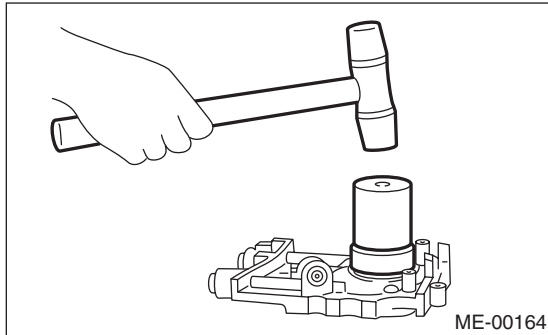

(2) Apply liquid gasket to the matching surface of oil pump.

Liquid gasket:

THREE BOND 1215 (Part No. 004403007) or equivalent

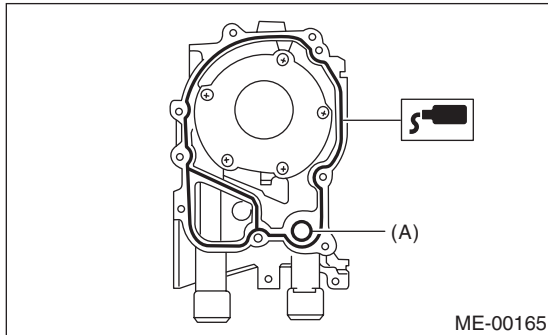

(A) O-ring

(3) Apply a coat of engine oil to the inside of oil seal.

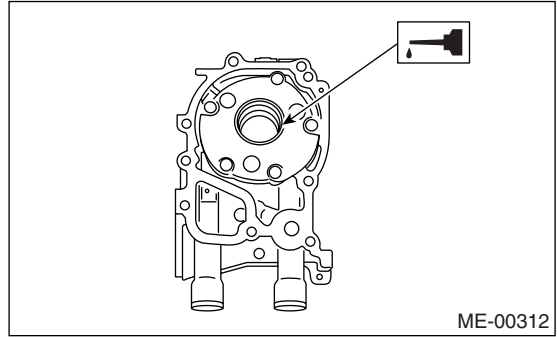

(4) Install the oil pump on cylinder block. Be careful not to damage the oil seal during installation.

Tightening torque:

6.4 N·m (0.65 kgf-m, 4.7 ft-lb)

CAUTION:

- Be sure to install the O-ring and seal when installing oil pump.
- Align flat surface of oil pump's inner rotor with crankshaft before installation.

27) Install the water pump and gasket.

Tightening torque:

First; 12 N·m (1.2 kgf-m, 8.7 ft-lb)

Second; 12 N·m (1.2 kgf-m, 8.7 ft-lb)

CAUTION:

- Be sure to use a new gasket.
- When installing the water pump, tighten the bolts in two stages in alphabetical sequence as shown in the figure.
- Model without ATF warmer

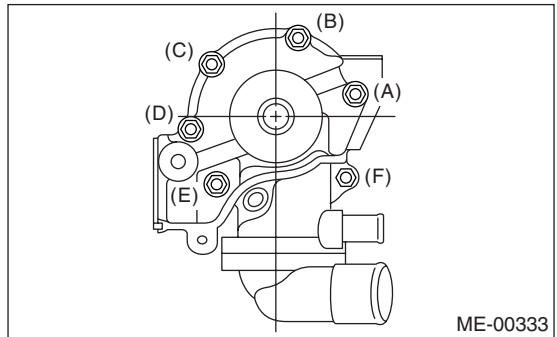

- Model with ATF warmer

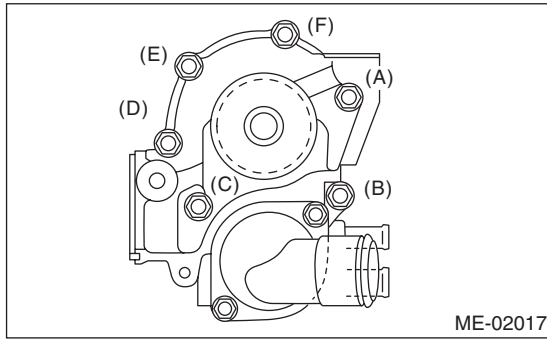

- 28) Install the water by-pass pipe for heater.
- 29) Get a engine oil filter and apply a thin coat of engine oil to the seal rubber.
- 30) Install the oil filter by turning it by hand, being careful not to damage the seal rubber.
- Tighten the oil filter 80 mm (3.15 in) or 65 mm (2.56 in) in diameter by approx. 2/3 — 3/4 rotation more after the seal rubber of oil filter comes in contact with cylinder block or oil cooler.
 - Tighten the oil filter 68 mm (2.68 in) in diameter by approx. 1 rotation more after the seal rubber of oil filter comes in contact with cylinder block or oil cooler.

CAUTION:

Do not tighten excessively, or oil may leak.

- 31) Tighten the cylinder head bolts.
- (1) Apply a coat of engine oil to washers and bolt threads.
 - (2) Tighten all bolts to 29 N·m (3.0 kgf-m, 22 ft-lb) in alphabetical sequence.
Then tighten all bolts to 69 N·m (7.0 kgf-m, 51 ft-lb) in alphabetical sequence.
 - (3) Back off all bolts by 180° in reverse order of installation, and back them off again by 180°.
 - (4) Tighten all bolts to 42 N·m (3.9 kgf-m, 31 ft-lb) in alphabetical sequence.
 - (5) Tighten all bolts by 80° — 90° in alphabetical sequence.
 - (6) Tighten all bolts by 40° — 45° in alphabetical sequence.

NOTE:

Do not tighten the bolts more than 45°.

- (7) Further tighten bolts (a) and (b) by 40° — 45°.

NOTE:

Ensure the total “re-tightening angle” in the [former two steps], do not exceed 90°.

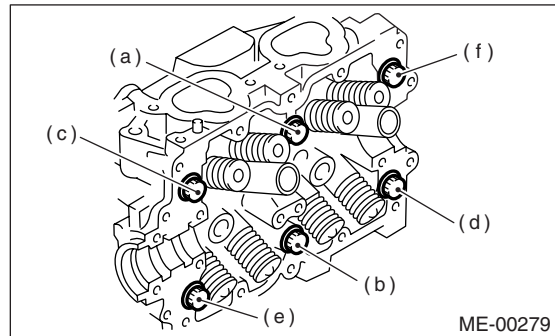

- 32) Install the oil level gauge guide and tighten the attaching bolt (left side only).
- 33) Install the rocker cover.
- 34) Install the crank sprocket. <Ref. to ME(H4SO)-55, INSTALLATION, Crank Sprocket.>
- 35) Install the cam sprocket. <Ref. to ME(H4SO)-53, INSTALLATION, Cam Sprocket.>
- 36) Install the timing belt assembly. <Ref. to ME(H4SO)-49, INSTALLATION, Timing Belt.>
- 37) Install the belt cover. <Ref. to ME(H4SO)-47, INSTALLATION, Timing Belt Cover.>
- 38) Install the crank pulley. <Ref. to ME(H4SO)-45, INSTALLATION, Crank Pulley.>
- 39) Install the generator and A/C compressor brackets on cylinder head.
- 40) Install the V-belt. <Ref. to ME(H4SO)-43, INSTALLATION, V-belt.>
- 41) Install the intake manifold. <Ref. to FU(H4SO)-16, INSTALLATION, Intake Manifold.>

Cylinder Block

MECHANICAL

C: DISASSEMBLY

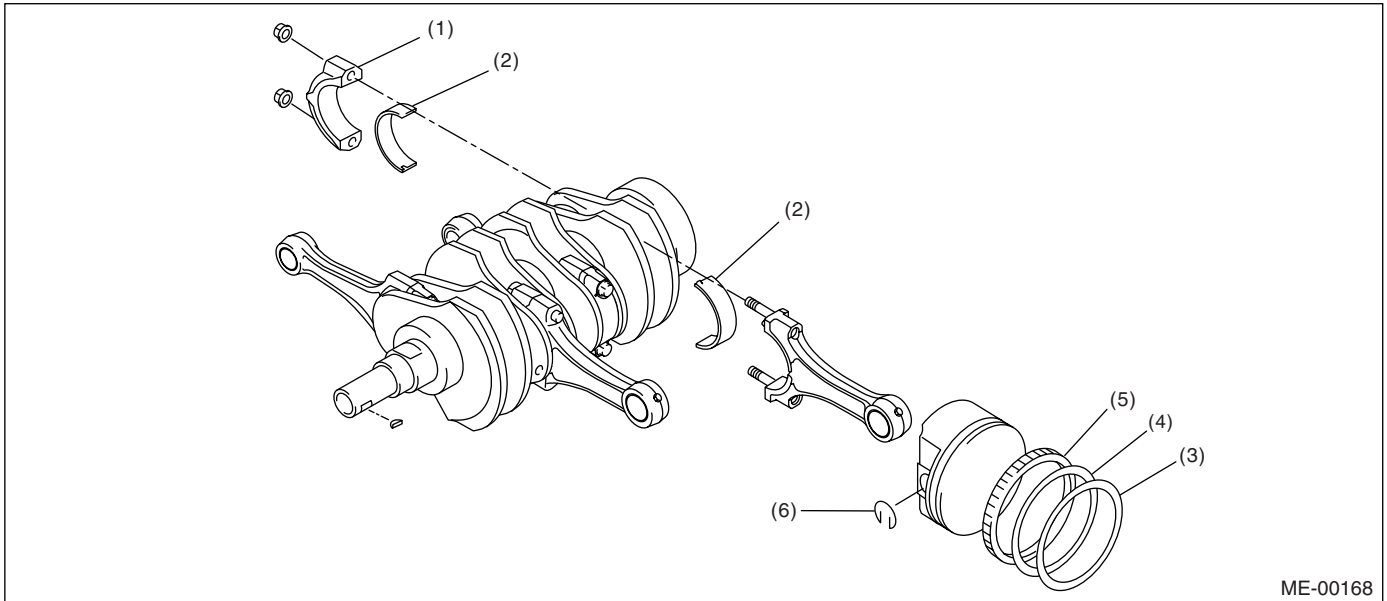

ME-00168

(1) Connecting rod cap

(3) Top ring

(5) Oil ring

(2) Connecting rod bearing

(4) Second ring

(6) Snap ring

1) Remove the connecting rod cap.

2) Remove the connecting rod bearing.

NOTE:

Arrange the removed connecting rod, connecting rod cap and bearing in order to prevent confusion.

3) Remove the piston rings using the piston ring expander.

4) Remove the oil ring by hand.

NOTE:

Arrange the removed piston rings in good order to prevent confusion.

5) Remove the snap ring.

D: ASSEMBLY

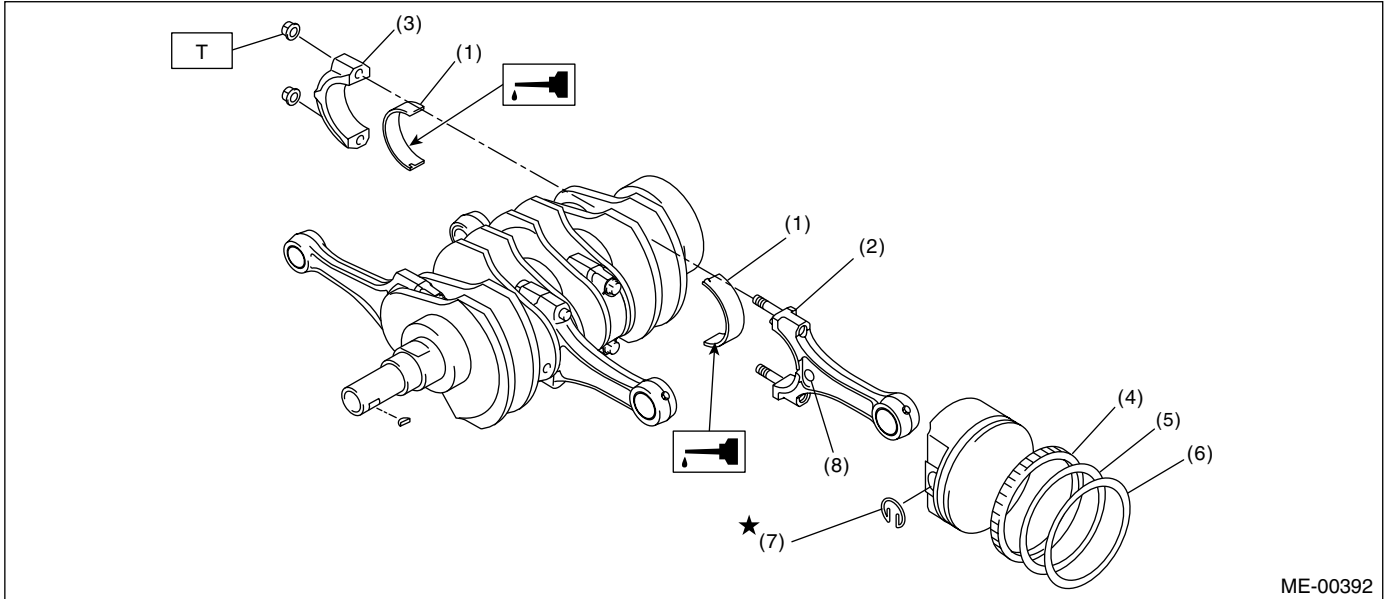

ME-00392

- | | |
|----------------------------|-----------------|
| (1) Connecting rod bearing | (5) Second ring |
| (2) Connecting rod | (6) Top ring |
| (3) Connecting rod cap | (7) Snap ring |
| (4) Oil ring | (8) Side mark |

Tightening torque: N·m (kgf·m, ft·lb)
T: 45 (4.6, 33)

1) Apply oil to the surfaces of the connecting rod bearings.

2) Install the connecting rod bearings on connecting rods and connecting rod caps.

3) Position each connecting rod with the marked side facing forward, and then install them.

4) Install the connecting rod cap with connecting rod nut.

Ensure the arrow on connecting rod cap faces the front during installation.

CAUTION:

- Each connecting rod has its own mating cap. Make sure that they are assembled correctly by checking their matching number.

- When tightening the connecting rod nuts, apply oil on the threads.

5) Install the expander, lower rail and upper rail in this order by hand. Then install the second ring and top ring with a piston ring expander.

Cylinder Block

MECHANICAL

E: INSPECTION

1. CYLINDER BLOCK

- 1) Visually check for cracks and damage. Especially, inspect the important parts by means of red lead check.
- 2) Check the oil passages for clogging.
- 3) Inspect the crankcase surface that mates with cylinder head for warping by using a straight edge, and correct by grinding if necessary.

Warping limit:
0.05 mm (0.0020 in)

Grinding limit:
0.1 mm (0.004 in)

Standard height of cylinder block:
201.0 mm (7.91 in)

2. CYLINDER AND PISTON

- 1) The cylinder bore size is stamped on cylinder block's front upper surface.

NOTE:

- Measurement should be performed at a temperature 20°C (68°F).
- Standard sized pistons are classified into two grades, "A" and "B". These grades should be used as a guide line in selecting a standard piston.

Standard diameter:

2.0 L model

A: 92.005 — 92.015 mm (3.6222 — 3.6226 in)

B: 91.995 — 92.005 mm (3.6218 — 3.6222 in)

2.5 L model

A: 99.505 — 99.515 mm (3.9175 — 3.9179 in)

B: 99.495 — 99.505 mm (3.9171 — 3.9175 in)

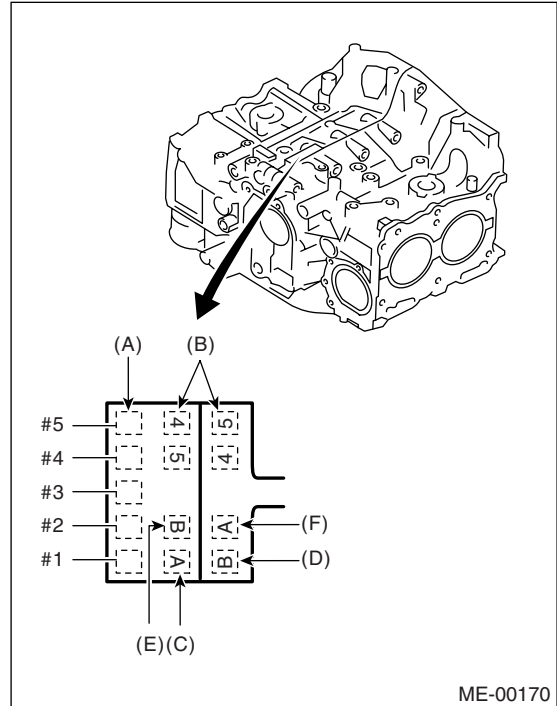

- (A) Main journal size mark
- (B) Cylinder block RH-LH combination mark
- (C) #1 cylinder bore size mark
- (D) #2 cylinder bore size mark
- (E) #3 cylinder bore size mark
- (F) #4 cylinder bore size mark

- 2) How to measure the inner diameter of each cylinder

Measure the inner diameter of each cylinder in both the thrust and piston pin directions at the heights shown in the figure, using a cylinder bore gauge.

NOTE:

Measurement should be performed at a temperature 20°C (68°F).

Taper:

Standard
0.015 mm (0.0006 in)

Limit
0.050 mm (0.0020 in)

Out-of-roundness:

Standard

0.010 mm (0.0004 in)

Limit

0.050 mm (0.0020 in)

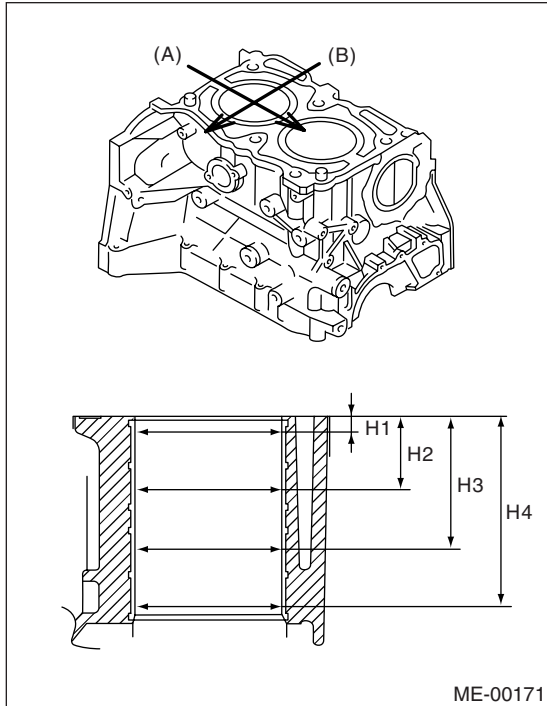

- (A) Piston pin direction
- (B) Thrust direction
- H1 10 mm (0.39 in)
- H2 45 mm (1.77 in)
- H3 80 mm (3.15 in)
- H4 115 mm (4.35 in)

3) When the piston is to be replaced due to general or cylinder wear, determine a suitable sized piston by measuring the piston clearance.

4) How to measure the outer diameter of each piston

Measure the outer diameter of each piston at the height shown in the figure. (Thrust direction)

NOTE:

Measurement should be performed at a temperature of 20°C (68°F).

Piston grade point H:

2.0 L model

40.0 mm (1.575 in)

2.5 L model

37.0 mm (1.457 in)

Piston outer diameter:

Standard:

2.0 L model

A: 91.985 — 91.995 mm (3.6214 — 3.6218 in)

B: 91.975 — 91.985 mm (3.6211 — 3.6214 in)

0.25 mm (0.0098 in) oversize

92.225 — 92.235 mm (3.6309 — 3.6313 in)

0.50 mm (0.0197 in) oversize

92.475 — 92.485 mm (3.6407 — 3.6411 in)

2.5 L model

A: 99.485 — 99.495 mm (3.9167 — 3.9171 in)

B: 99.475 — 99.485 mm (3.9163 — 3.9167 in)

0.25 mm (0.0098 in) oversize

99.725 — 99.735 mm (3.9262 — 3.9266 in)

0.50 mm (0.0197 in) oversize

99.975 — 99.985 mm (3.9360 — 3.9364 in)

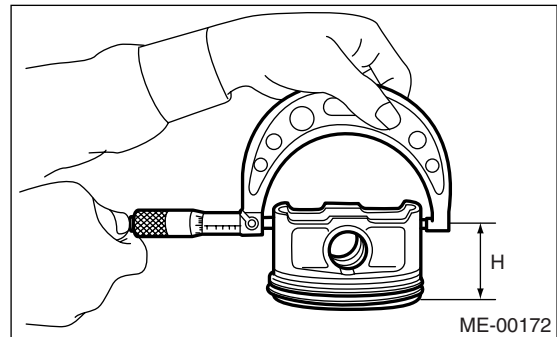

5) Calculate the clearance between cylinder and piston.

NOTE:

Measurement should be performed at a temperature of 20°C (68°F).

Cylinder to piston clearance at 20°C (68°F):

Standard

0.010 — 0.030 mm (0.0004 — 0.0012 in)

Limit

0.050 mm (0.0020 in)

6) Boring and honing

(1) If the value of taper, out-of-roundness, or cylinder-to-piston clearance measured exceeds the specified limit or if there is any damage on the cylinder wall, rebores it to use an oversize piston.

CAUTION:

When any of the cylinders needs reboring, all other cylinders must be bored at the same time, and use oversize pistons. Do not perform boring on one cylinder only, nor use an oversize piston for one cylinder only.

(2) If the cylinder inner diameter exceeds the limit after boring and honing, replace the crankcase.

Cylinder Block

MECHANICAL

NOTE:

Immediately after reboring, the cylinder diameter may differ from its real diameter due to temperature rise. Thus, pay attention to this when measuring the cylinder diameter.

Limit of cylinder enlarging (boring):

0.5 mm (0.020 in)

3. PISTON AND PISTON PIN

1) Check the pistons and piston pins for damage, cracks, and wear and the piston ring grooves for wear and damage. Replace if defective.

2) Measure the piston-to-cylinder clearance at each cylinder. <Ref. to ME(H4SO)-84, CYLINDER AND PISTON, INSPECTION, Cylinder Block.> If any of the clearances is not to specification, replace the piston or bore the cylinder to use an over-size piston.

3) Make the sure that piston pin can be inserted into piston pin hole with a thumb at 20°C (68°F). Replace if defective.

Standard clearance between piston pin and hole in piston:

Standard

0.004 — 0.008 mm (0.0002 — 0.0003 in)

Limit

0.020 mm (0.0008 in)

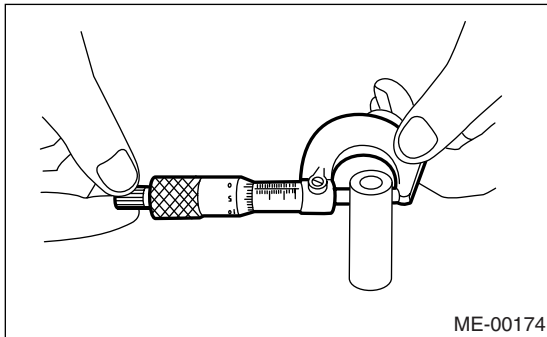
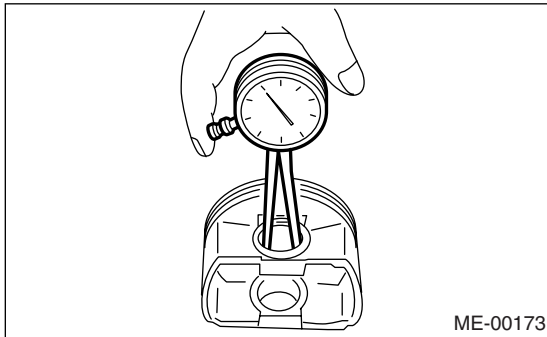

4) Check the circlip installation groove (A) on piston for burr. If necessary, remove the burr from groove so that piston pin can lightly move.

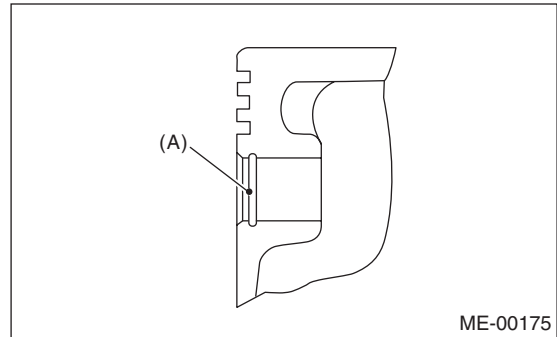

5) Check the piston pin circlip for distortion, cracks and wear.

4. PISTON RING

1) If the piston ring is broken, damaged, or worn, or if its tension is insufficient, or when the piston is replaced, replace the piston ring with a new one of the same size as the piston.

CAUTION:

- Marks are shown on the end of top and second rings. When installing the rings to piston, face these marks upward.
- Oil ring is composed of upper rail, expander and lower rail. Be careful of the rail direction when installing oil ring to the piston.

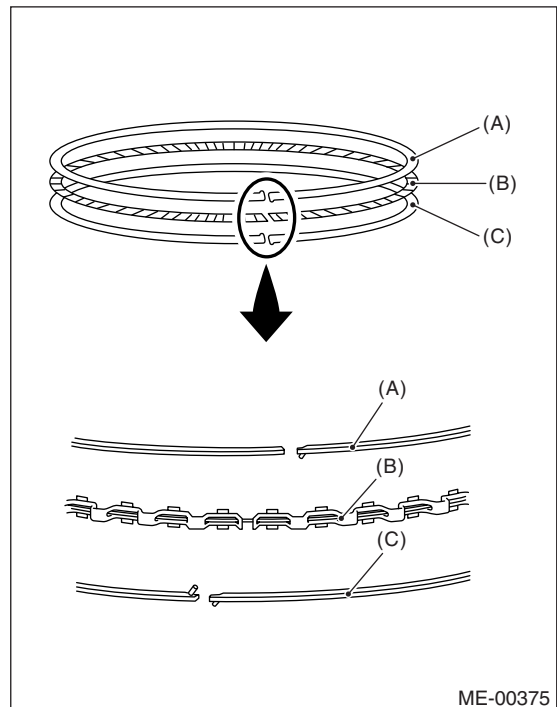

- (A) Upper rail
- (B) Expander
- (C) Lower rail

- 2) Clean the piston ring groove and piston ring.
- 3) Squarely place the piston ring and oil ring in cylinder, and then measure the piston ring gap with a thickness gauge.

Unit: mm (in)				
		Standard	Limit	
Piston ring gap	Top ring	0.20 — 0.35 (0.0079 — 0.0138)	1.0 (0.039)	
	Second ring	2.0 L	0.35 — 0.50 (0.0138 — 0.0197)	1.0 (0.039)
		2.5 L	0.37 — 0.52 (0.0146 — 0.0204)	
	Oil ring rail		0.20 — 0.50 (0.0079 — 0.0197)	1.5 (0.059)

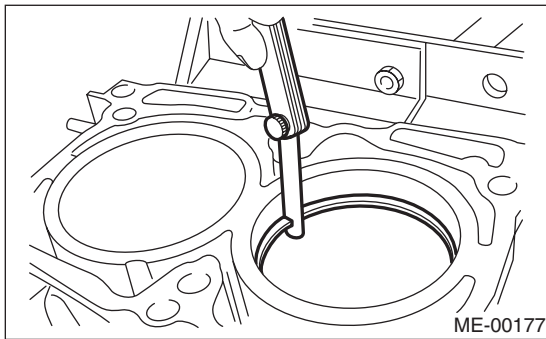

- 4) Measure the clearance between piston ring and piston ring groove with a thickness gauge.

Unit: mm (in)			
		Standard	Limit
Clearance between piston ring and piston ring groove	Top ring	0.040 — 0.080 (0.0016 — 0.0031)	0.15 (0.0059)
	Second ring	0.030 — 0.070 (0.0012 — 0.0028)	

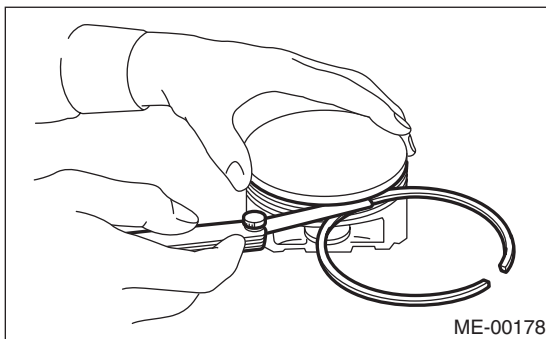

5. CONNECTING ROD

- 1) Replace the connecting rod, if the large or small end thrust surface is damaged.
- 2) Check for bend or twist using a connecting rod aligner. Replace the connecting rod if the bend or twist exceeds the limit.

Limit of bend or twist per 100 mm (3.94 in) in length:

0.10 mm (0.0039 in)

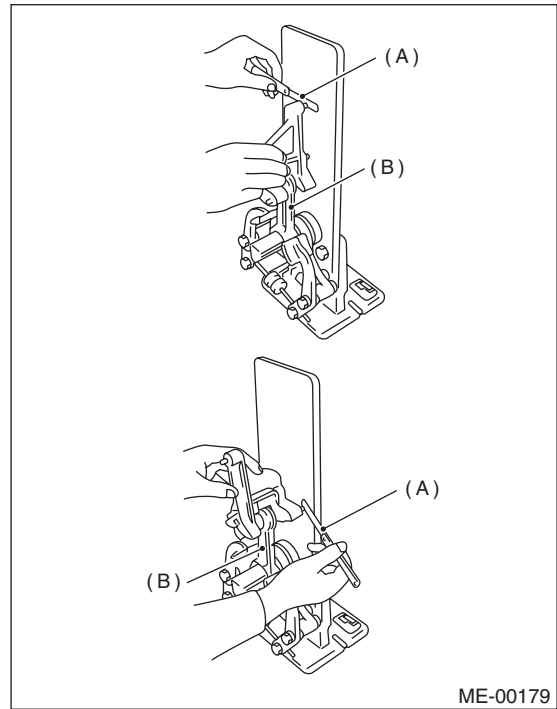

- (A) Thickness gauge
(B) Connecting rod

- 3) Install the connecting rod fitted with bearing to crankshaft, and then measure the side clearance (thrust clearance). Replace the connecting rod if the side clearance exceeds the specified limit.

Connecting rod side clearance:

Standard

0.070 — 0.330 mm (0.0028 — 0.0130 in)

Limit

0.4 mm (0.016 in)

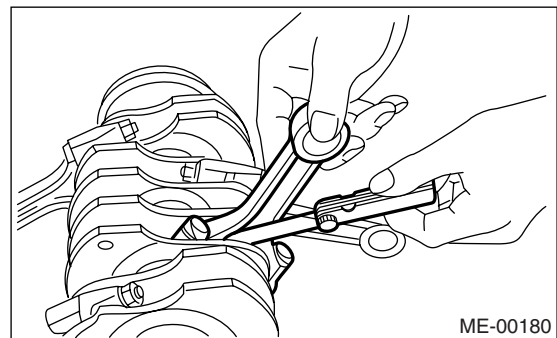

- 4) Inspect the connecting rod bearing for scar, peeling, seizure, melting, wear, etc.
- 5) Measure the oil clearance on individual connecting rod bearings by means of plastigage. If any oil clearance is not within specification, replace the defective bearing with a new one of standard size or undersize as necessary. (See the table below.)

Cylinder Block

MECHANICAL

Connecting rod oil clearance:

Standard

0.0158 — 0.0438 mm (0.0006 — 0.0017 in)

Limit

0.05 mm (0.0020 in)

Unit: mm (in)		
Bearing	Bearing size (Thickness at center)	Outer diameter of crank pin
Standard	1.492 — 1.501 (0.0587 — 0.0591)	51.984 — 52.000 (2.0466 — 2.0472)
0.03 (0.0012) undersize	1.510 — 1.513 (0.0594 — 0.0596)	51.954 — 51.970 (2.0454 — 2.0461)
0.05 (0.0020) undersize	1.520 — 1.523 (0.0598 — 0.0600)	51.934 — 51.950 (2.0446 — 2.0453)
0.25 (0.0098) undersize	1.620 — 1.623 (0.0638 — 0.0639)	51.734 — 51.750 (2.0368 — 2.0374)

6) Inspect the bushing at connecting rod small end, and replace if worn or damaged. Also measure the piston pin clearance at connecting rod small end.

Clearance between piston pin and bushing:

Standard

0 — 0.022 mm (0 — 0.0009 in)

Limit

0.030 mm (0.0012 in)

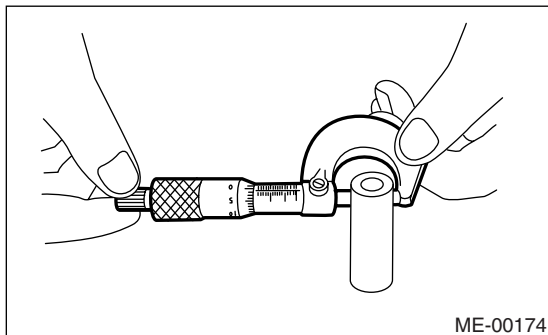
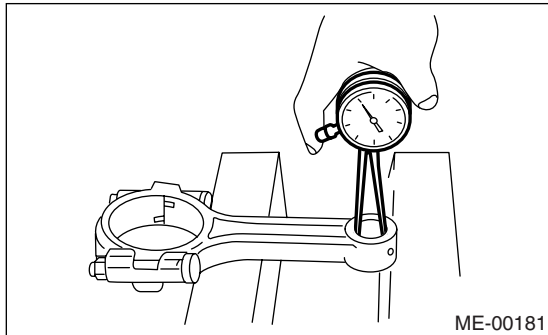

7) Replacement procedure is as follows.

(1) Remove the bushing from connecting rod with ST and press.

(2) Press the bushing with ST after applying oil on the periphery of bushing.

ST 499037100 CONNECTING ROD BUSHING REMOVER AND INSTALLER

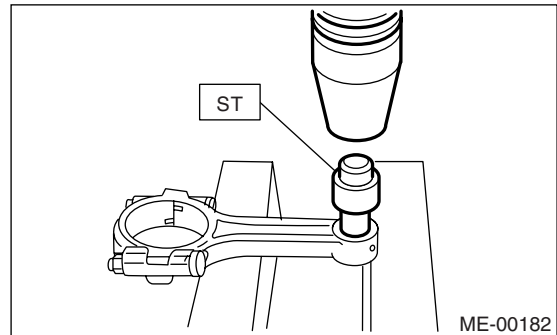

(3) Make two 3 mm (0.12 in) holes in bushing. Ream the inside of bushing.

(4) After the completion of reaming, clean the bushing to remove chips.

6. CRANKSHAFT AND CRANKSHAFT BEARING

1) Clean the crankshaft completely and check for cracks by means of red lead check etc., and replace if defective.

2) Measure the crankshaft bend, and correct or replace if it exceeds the limit.

NOTE:

If a suitable V-block is not available, install the #1 and #5 crankshaft bearing on cylinder block, position the crankshaft on these bearings and measure the crankshaft bend using a dial gauge.

Crankshaft bend limit:

0.035 mm (0.0014 in)

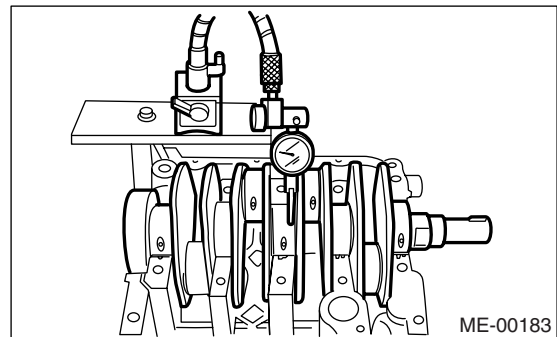

3) Inspect the crank journal and crank pin for wear. If they are not within the specifications, replace the bearing with a suitable (undersize) one, and then replace or recondition the crankshaft as necessary. When grinding the crank journal or crank pin, finish them to specified dimensions according to the undersize bearing to be used.

Crank pin and crank journal:

Out-of-roundness

0.020 mm (0.0008 in) or less

Taper limit

0.07 mm (0.0028 in)

Grinding limit

0.250 mm (0.0098 in)

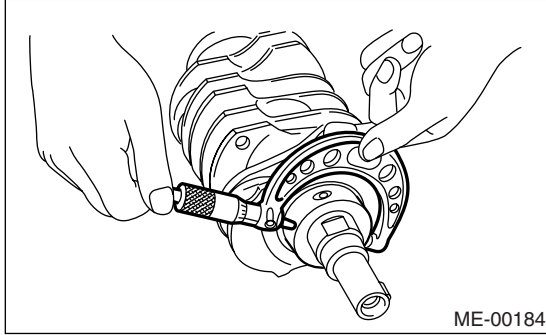

Cylinder Block

MECHANICAL

		Unit: mm (in)			
		Crank journal diameter		Crank pin diameter	
		#1, #3	#2, #4, #5	2.0 L	2.5 L
Standard	Journal O.D.	59.992 — 60.008 (2.3619 — 2.3625)	59.992 — 60.008 (2.3619 — 2.3625)	51.984 — 52.000 (2.0466 — 2.0472)	51.984 — 52.000 (2.0466 — 2.0472)
	Bearing size (Thickness at center)	1.998 — 2.011 (0.0787 — 0.0792)	2.000 — 2.013 (0.0787 — 0.0793)	1.492 — 1.501 (0.0587 — 0.0591)	1.490 — 1.502 (0.0587 — 0.0591)
0.03 (0.0012) undersize	Journal O.D.	59.962 — 59.978 (2.3607 — 2.3613)	59.962 — 59.978 (2.3607 — 2.3613)	51.954 — 51.970 (2.0454 — 2.0461)	51.954 — 51.970 (2.0454 — 2.0461)
	Bearing size (Thickness at center)	2.017 — 2.020 (0.0794 — 0.0795)	2.019 — 2.022 (0.0795 — 0.0796)	1.510 — 1.513 (0.0594 — 0.0596)	1.504 — 1.512 (0.0592 — 0.0595)
0.05 (0.0020) undersize	Journal O.D.	59.942 — 59.958 (2.3599 — 2.3605)	59.942 — 59.958 (2.3599 — 2.3605)	51.934 — 51.950 (2.0446 — 2.0453)	51.934 — 51.950 (2.0446 — 2.0453)
	Bearing size (Thickness at center)	2.027 — 2.030 (0.0798 — 0.0799)	2.029 — 2.032 (0.0799 — 0.0800)	1.520 — 1.523 (0.0598 — 0.0600)	1.514 — 1.522 (0.0596 — 0.0599)
0.25 (0.0098) undersize	Journal O.D.	59.742 — 59.758 (2.3520 — 2.3527)	59.742 — 59.758 (2.3520 — 2.3527)	51.734 — 51.750 (2.0368 — 2.0374)	51.734 — 51.750 (2.0368 — 2.0374)
	Bearing size (Thickness at center)	2.127 — 2.130 (0.0837 — 0.0839)	2.129 — 2.132 (0.0838 — 0.0839)	1.620 — 1.623 (0.0638 — 0.0639)	1.614 — 1.622 (0.0635 — 0.0639)

O.D.: Outer Diameter

4) Measure the thrust clearance of crankshaft at center bearing. If the clearance exceeds the limit, replace bearing.

Crankshaft thrust clearance:

Standard

0.030 — 0.115 mm (0.0012 — 0.0045 in)

Limit

0.25 mm (0.0098 in)

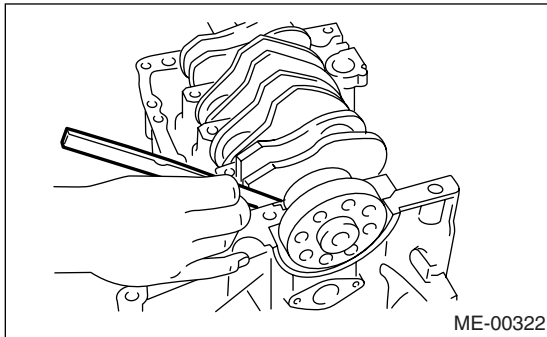

5) Inspect the individual crankshaft bearings for signs of flaking, seizure, melting, and wear.

6) Measure the oil clearance on each crankshaft bearing by means of plastigage. If the measurement is not within the specification, replace the defective bearing with an undersize one, and then replace or recondition the crankshaft as necessary.

		Unit: mm (in)	
		Crankshaft oil clearance	
#1	Standard	0.010 — 0.030 (0.0004 — 0.0012)	
	Limit	0.040 (0.0016)	
#2	Standard	0.010 — 0.030 (0.0004 — 0.0012)	
	Limit	0.045 (0.0018)	
#3	Standard	0.010 — 0.030 (0.0004 — 0.0012)	
	Limit	0.040 (0.0016)	
#4	Standard	0.010 — 0.030 (0.0004 — 0.0012)	
	Limit	0.045 (0.0018)	
#5	Standard	0.010 — 0.030 (0.0004 — 0.0012)	
	Limit	0.040 (0.0016)	

22.Engine Trouble in General

A: INSPECTION

NOTE:

“RANK” shown in the chart refer to the possibility of reason for the trouble in order (“Very often” to “Rarely”)

A — Very often

B — Sometimes

C — Rarely

TROUBLE	PROBLEM PARTS, ETC.	POSSIBLE CAUSE	RANK
1. Engine will not start.			
1) Starter does not turn.	Starter	Defective battery-to-starter harness	B
		Defective starter switch	C
		Defective inhibitor switch or neutral switch	C
		Defective starter	B
	Battery	Poor terminal connection	A
		Run-down battery	A
		Defective charging system	B
	Friction	Seizure of crankshaft and connecting rod bearing	C
		Seized camshaft	C
Seized or stuck piston and cylinder		C	
2) Initial combustion does not occur.	Starter	Defective starter	C
	Engine control system <Ref. to EN(H4SO)-2, Basic Diagnostics Procedure.>		A
	Fuel line	Defective fuel pump and relay	A
		Lack of or insufficient fuel	B
	Belt	Defective	B
		Defective timing	B
	Compression	Incorrect valve clearance	C
		Loosened spark plugs or defective gasket	C
		Loosened cylinder head bolts or defective gasket	C
		Improper valve seating	C
		Defective valve stem	C
		Worn or broken valve spring	B
		Worn or stuck piston rings, cylinder and piston	C
		Incorrect valve timing	B
Improper engine oil (low viscosity)	B		
3) Initial combustion occurs.	Engine control system <Ref. to EN(H4SO)-2, Basic Diagnostics Procedure.>		A
	Intake system	Defective intake manifold gasket	B
		Defective throttle body gasket	B
	Fuel line	Defective fuel pump and relay	C
		Clogged fuel line	C
		Lack of or insufficient fuel	B
	Belt	Defective	B
		Defective timing	B
	Compression	Incorrect valve clearance	C
		Loosened spark plugs or defective gasket	C
		Loosened cylinder head bolts or defective gasket	C
		Improper valve seating	C
		Defective valve stem	C
		Worn or broken valve spring	B
Worn or stuck piston rings, cylinder and piston		C	
Incorrect valve timing		B	
Improper engine oil (low viscosity)	B		

Engine Trouble in General

MECHANICAL

TROUBLE	PROBLEM PARTS, ETC.	POSSIBLE CAUSE	RANK
4) Engine stalls after initial combustion.	Engine control system <Ref. to EN(H4SO)-2, Basic Diagnostics Procedure.>		A
	Intake system	Loosened or cracked intake duct	B
		Loosened or cracked PCV hose	C
		Loosened or cracked vacuum hose	C
		Defective intake manifold gasket	B
		Defective throttle body gasket	B
		Dirty air cleaner element	C
	Fuel line	Clogged fuel line	C
		Lack of or insufficient fuel	B
	Belt	Defective	B
		Defective timing	B
	Compression	Incorrect valve clearance	C
		Loosened spark plugs or defective gasket	C
		Loosened cylinder head bolts or defective gasket	C
		Improper valve seating	C
		Defective valve stem	C
		Worn or broken valve spring	B
Worn or stuck piston rings, cylinder and piston		C	
Incorrect valve timing		B	
Improper engine oil (low viscosity)	B		
2. Rough idle and engine stall	Engine control system <Ref. to EN(H4SO)-2, Basic Diagnostics Procedure.>		A
	Intake system	Loosened or cracked intake duct	A
		Loosened or cracked PCV hose	A
		Loosened or cracked vacuum hose	A
		Defective intake manifold gasket	B
		Defective throttle body gasket	B
		Defective PCV valve	C
		Loosened oil filler cap	B
		Dirty air cleaner element	C
	Fuel line	Defective fuel pump and relay	C
		Clogged fuel line	C
		Lack of or insufficient fuel	B
	Belt	Defective timing	C
	Compression	Incorrect valve clearance	B
		Loosened spark plugs or defective gasket	B
		Loosened cylinder head bolts or defective gasket	B
		Improper valve seating	B
		Defective valve stem	C
		Worn or broken valve spring	B
		Worn or stuck piston rings, cylinder and piston	B
		Incorrect valve timing	A
	Improper engine oil (low viscosity)	B	
	Lubrication system	Incorrect oil pressure	B
		Defective rocker cover gasket	C
	Cooling system	Overheating	C
	Others	Malfunction of evaporative emission control system	A
		Stuck or damaged throttle valve	B
		Accelerator cable out of adjustment	C

Engine Trouble in General

MECHANICAL

TROUBLE	PROBLEM PARTS, ETC.	POSSIBLE CAUSE	RANK
3. Low output, hesitation and poor acceleration	Engine control system <Ref. to EN(H4SO)-2, Basic Diagnostics Procedure.>		A
	Intake system	Loosened or cracked intake duct	A
		Loosened or cracked PCV hose	A
		Loosened or cracked vacuum hose	B
		Defective intake manifold gasket	B
		Defective throttle body gasket	B
		Defective PCV valve	B
		Loosened oil filler cap	B
		Dirty air cleaner element	A
	Fuel line	Defective fuel pump and relay	B
		Clogged fuel line	B
		Lack of or insufficient fuel	C
	Belt	Defective timing	B
	Compression	Incorrect valve clearance	B
		Loosened spark plugs or defective gasket	B
		Loosened cylinder head bolts or defective gasket	B
		Improper valve seating	B
		Defective valve stem	C
		Worn or broken valve spring	B
		Worn or stuck piston rings, cylinder and piston	C
		Incorrect valve timing	A
	Improper engine oil (low viscosity)	B	
	Lubrication system	Incorrect oil pressure	B
Cooling system	Overheating	C	
	Over cooling	C	
Others	Malfunction of evaporative emission control system	A	
4. Surging	Engine control system <Ref. to EN(H4SO)-2, Basic Diagnostics Procedure.>		A
	Intake system	Loosened or cracked intake duct	A
		Loosened or cracked PCV hose	A
		Loosened or cracked vacuum hose	A
		Defective intake manifold gasket	B
		Defective throttle body gasket	B
		Defective PCV valve	B
		Loosened oil filler cap	B
		Dirty air cleaner element	B
	Fuel line	Defective fuel pump and relay	B
		Clogged fuel line	B
		Lack of or insufficient fuel	C
	Belt	Defective timing	B
	Compression	Incorrect valve clearance	B
		Loosened spark plugs or defective gasket	C
		Loosened cylinder head bolts or defective gasket	C
		Improper valve seating	C
		Defective valve stem	C
		Worn or broken valve spring	C
		Worn or stuck piston rings, cylinder and piston	C
		Incorrect valve timing	A
	Improper engine oil (low viscosity)	B	
	Cooling system	Overheating	B
Others	Malfunction of evaporative emission control system	C	

Engine Trouble in General

MECHANICAL

TROUBLE	PROBLEM PARTS, ETC.	POSSIBLE CAUSE	RANK
5. Engine does not return to idle.	Engine control system <Ref. to EN(H4SO)-2, Basic Diagnostics Procedure.>		A
	Intake system	Loosened or cracked vacuum hose	A
	Others	Stuck or damaged throttle valve	A
		Accelerator cable out of adjustment	B
6. Dieseling (Run-on)	Engine control system <Ref. to EN(H4SO)-2, Basic Diagnostics Procedure.>		A
	Cooling system	Overheating	B
	Others	Malfunction of evaporative emission control system	B
7. After burning in exhaust system	Engine control system <Ref. to EN(H4SO)-2, Basic Diagnostics Procedure.>		A
	Intake system	Loosened or cracked intake duct	C
		Loosened or cracked PCV hose	C
		Loosened or cracked vacuum hose	B
		Defective PCV valve	B
		Loosened oil filler cap	C
	Belt	Defective timing	B
	Compression	Incorrect valve clearance	B
		Loosened spark plugs or defective gasket	C
		Loosened cylinder head bolts or defective gasket	C
		Improper valve seating	B
		Defective valve stem	C
		Worn or broken valve spring	C
		Worn or stuck piston rings, cylinder and piston	C
		Incorrect valve timing	A
Lubrication system	Incorrect oil pressure	C	
Cooling system	Over cooling	C	
Others	Malfunction of evaporative emission control system	C	
8. Knocking	Engine control system <Ref. to EN(H4SO)-2, Basic Diagnostics Procedure.>		A
	Intake system	Loosened oil filler cap	B
	Belt	Defective timing	B
	Compression	Incorrect valve clearance	C
		Incorrect valve timing	B
	Cooling system	Overheating	A
9. Excessive engine oil consumption	Intake system	Loosened or cracked PCV hose	A
		Defective PCV valve	B
		Loosened oil filler cap	C
	Compression	Defective valve stem	A
		Worn or stuck piston rings, cylinder and piston	A
	Lubrication system	Loosened oil pump attaching bolts and defective gasket	B
		Defective oil filter seal	B
		Defective crankshaft oil seal	B
		Defective rocker cover gasket	B
		Loosened oil drain plug or defective gasket	B
	Loosened oil pan fitting bolts or defective oil pan	B	

Engine Trouble in General

MECHANICAL

TROUBLE	PROBLEM PARTS, ETC.	POSSIBLE CAUSE	RANK	
10. Excessive fuel consumption	Engine control system <Ref. to EN(H4SO)-2, Basic Diagnostics Procedure.>		A	
	Intake system	Dirty air cleaner element	A	
	Belt	Defective timing	B	
	Compression	Incorrect valve clearance		B
		Loosened spark plugs or defective gasket		C
		Loosened cylinder head bolts or defective gasket		C
		Improper valve seating		B
		Defective valve stem		C
		Worn or broken valve spring		C
		Worn or stuck piston rings, cylinder and piston		B
		Incorrect valve timing		B
	Lubrication system	Incorrect oil pressure	C	
	Cooling system	Over cooling	C	
	Others	Accelerator cable out of adjustment	B	

Engine Noise

MECHANICAL

23.Engine Noise

A: INSPECTION

Type of sound	Condition	Possible cause
Regular clicking sound	Sound increases as engine speed increases.	<ul style="list-style-type: none"> Valve mechanism is defective. Incorrect valve clearance Worn valve rocker Worn camshaft Broken valve spring
Heavy and dull clank	Oil pressure is low.	<ul style="list-style-type: none"> Worn crankshaft main bearing Worn connecting rod bearing (big end)
	Oil pressure is normal.	<ul style="list-style-type: none"> Loose flywheel mounting bolts Damaged engine mounting
High-pitched clank (Spark knock)	Sound is noticeable when accelerating with an overload.	<ul style="list-style-type: none"> Ignition timing advanced Accumulation of carbon inside combustion chamber Wrong spark plug Improper gasoline
Clank when engine speed is medium (1,000 to 2,000 rpm).	Sound is reduced when fuel injector connector of noisy cylinder is disconnected. (NOTE*)	<ul style="list-style-type: none"> Worn crankshaft main bearing Worn bearing at crankshaft end of connecting rod
Knocking sound when engine is operating under idling speed and engine is warm	Sound is reduced when fuel injector connector of noisy cylinder is disconnected. (NOTE*)	<ul style="list-style-type: none"> Worn cylinder liner and piston ring Broken or stuck piston ring Worn piston pin and hole at piston end of connecting rod
	Sound is not reduced if each fuel injector connector is disconnected in turn. (NOTE*)	<ul style="list-style-type: none"> Unusually worn valve lifter Worn cam gear Worn camshaft journal bore in crankcase
Squeaky sound	—	Insufficient generator lubrication
Rubbing sound	—	Defective generator brush and rotor contact
Gear scream when starting engine	—	<ul style="list-style-type: none"> Defective ignition starter switch Worn gear and starter pinion
Sound like polishing glass with a dry cloth	—	<ul style="list-style-type: none"> Loose drive belt Defective water pump shaft
Hissing sound	—	<ul style="list-style-type: none"> Loss of compression Air leakage in air intake system, hoses, connections or manifolds
Timing belt noise	—	<ul style="list-style-type: none"> Loose timing belt Belt contacting case/adjacent part
Valve tappet noise	—	Incorrect valve clearance

NOTE*:

When disconnecting fuel injector connector, the malfunction indicator light illuminates and DTC is stored in ECM memory. Therefore, carry out the clear memory mode <Ref. to EN(H4SO)-44, OPERATION, Clear Memory Mode.> and inspection mode <Ref. to EN(H4SO)-37, OPERATION, Inspection Mode.> after connecting fuel injector connector.