

BODY SECTION

This service manual has been prepared to provide SUBARU service personnel with the necessary information and data for the correct maintenance and repair of SUBARU vehicles.

This manual includes the procedures for maintenance, disassembling, reassembling, inspection and adjustment of components and diagnostics for guidance of experienced mechanics.

Please peruse and utilize this manual fully to ensure complete repair work for satisfying our customers by keeping their vehicle in optimum condition. When replacement of parts during repair work is needed, be sure to use SUBARU genuine parts.

All information, illustration and specifications contained in this manual are based on the latest product information available at the time of publication approval.

HVAC SYSTEM (HEATER, VENTILATOR AND A/C)	AC
HVAC SYSTEM (AUTO A/C) (DIAGNOSTIC)	AC
AIRBAG SYSTEM	AB
AIRBAG SYSTEM (DIAGNOSTIC)	AB
SEAT BELT SYSTEM	SB
LIGHTING SYSTEM	LI
WIPER AND WASHER SYSTEM	WW
ENTERTAINMENT	ET
COMMUNICATION SYSTEM	COM
GLASS/WINDOW/MIRROR	GW
BODY STRUCTURE	BS
INSTRUMENTATION/DRIVER INFO	IDI
SEAT	SE
SECURITY AND LOCK	SL
SUNROOF/T-TOP/CONVERTIBLE TOP (SUNROOF)	SR
EXTERIOR/INTERIOR TRIM	EI
EXTERIOR BODY PANEL	EB

BODY SECTION

CRUISE CONTROL SYSTEM CC

CRUISE CONTROL SYSTEM (DIAGNOSTIC) CC(H4SO)

CRUISE CONTROL SYSTEM (DIAGNOSTIC) CC(H4DOTC)

CRUISE CONTROL SYSTEM (DIAGNOSTIC) CC(H4DOTC 2.5)

IMMOBILIZER (DIAGNOSTIC) IM

SUNROOF/T-TOP/CONVERTIBLE TOP (SUNROOF)

SR

	Page
1. General Description	2
2. Sunroof Control System	4
3. Sunroof Lid.....	5
4. Sunroof Assembly	6
5. Sunroof Motor	8
6. Sunroof Switch	9

General Description

SUNROOF/T-TOP/CONVERTIBLE TOP (SUNROOF)

1. General Description

A: COMPONENT

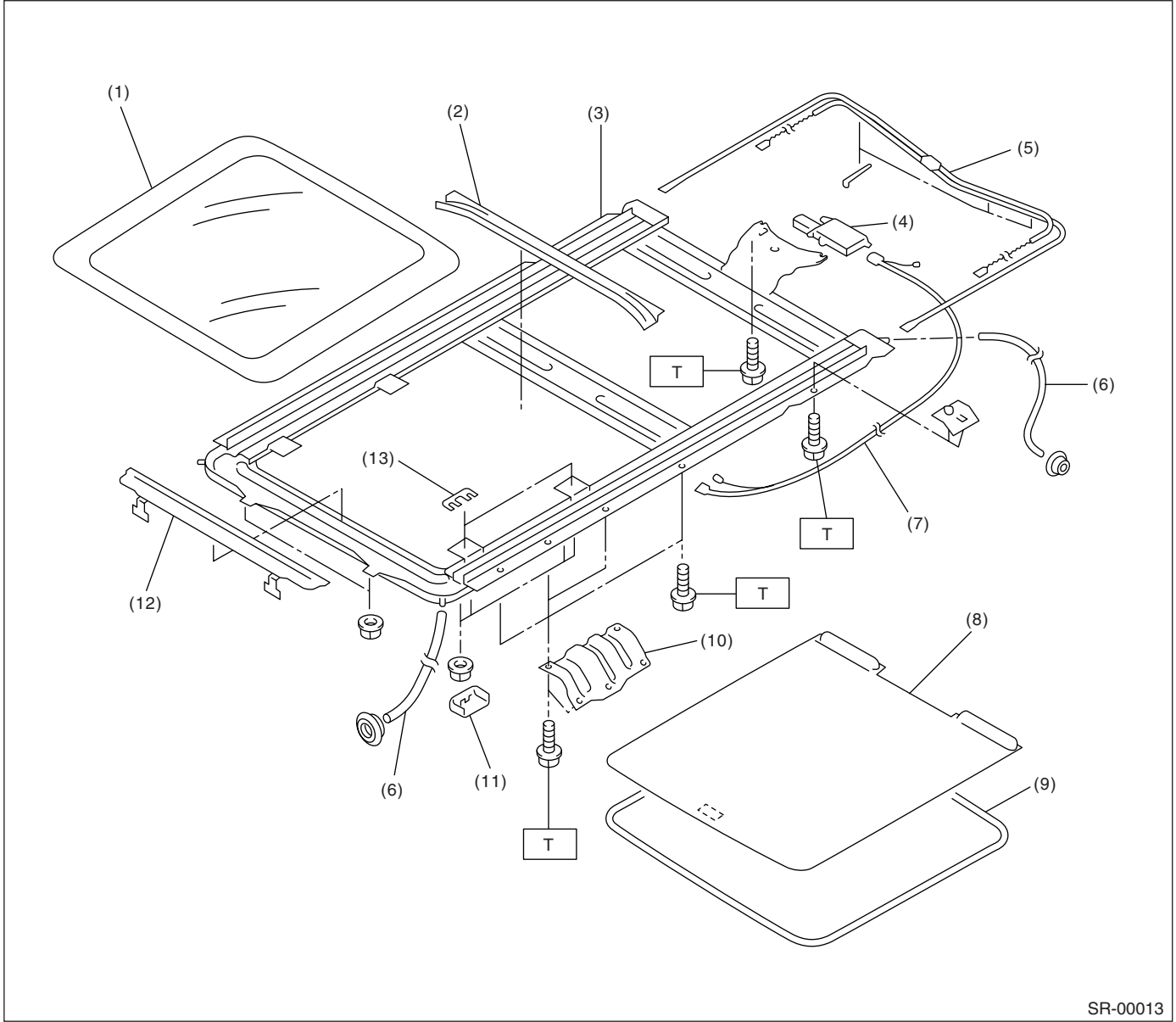

SR-00013

- (1) Sunroof lid
- (2) Rear drain ASSY
- (3) Frame ASSY
- (4) Motor ASSY
- (5) Drive unit
- (6) Drain tube

- (7) Harness
- (8) Sunshade
- (9) Garnish
- (10) Frame bracket
- (11) Cover
- (12) Deflector

- (13) Shim

Tightening torque: N·m (kgf·m, ft·lb)
T: 7.4 (0.75, 5.4)

General Description

SUNROOF/T-TOP/CONVERTIBLE TOP (SUNROOF)

B: CAUTION

- Before disassembling or reassembling parts, always disconnect battery ground cable. When replacing radio, control module and other parts provided with memory functions, record memory contents before disconnecting the battery ground cable. Otherwise, the memory will be erased.
- Reassemble in reverse order of disassembly, unless otherwise indicated.
- Adjust parts to the given specifications.
- Connect connectors and hoses securely during reassembly.
- After reassembly, make sure functional parts operate smoothly.

C: PREPARATION TOOL

1. GENERAL TOOL

TOOL NAME	REMARKS
Circuit tester	Used for measuring resistance and voltage.

Sunroof Control System

SUNROOF/T-TOP/CONVERTIBLE TOP (SUNROOF)

2. Sunroof Control System

A: WIRING DIAGRAM

1. SUNROOF

<Ref. to WI-263, WIRING DIAGRAM, Sunroof System.>

B: INSPECTION

Symptom	Checking order
Water leaks.	(1) Check roof panel and sunroof lid for improper or poor sealing. (2) Check drain tube for clogging. (3) Check sunroof frame seal and body for improper fit.
Booming noise	(1) Check sunroof lid and roof panel for improper clearance. (2) Check sunshade and roof trim for improper clearance.
Abnormal motor noise	(1) Check motor for looseness. (2) Check gears and bearings for wear. (3) Check cables for wear. (4) Check cable pipe for deformities.
Failure of sunroof (Motor operates properly.)	(1) Check guide rail for foreign particles. (2) Check guide rail for improper installation. (3) Check parts for mutual interference. (4) Check cable slider for improper clinching. (5) Check cable for improper installation. (6) Check clutch adjusting nut for improper tightness.
Motor does not rotate or rotates improperly.	(1) Check fuse for blow-out. (2) Check switch for improper function. (3) Check motor for incorrect terminal voltage. (4) Check relay for improper operation. (5) Check poor grounding system. (6) Check harness for open or short and terminals for poor connections. (7) Check limit switch for improper operation.

Sunroof Lid

SUNROOF/T-TOP/CONVERTIBLE TOP (SUNROOF)

3. Sunroof Lid

A: REMOVAL

- 1) Completely close sunroof lid and open sunshade.
- 2) Detach the four covers (A) and then remove eight nuts.

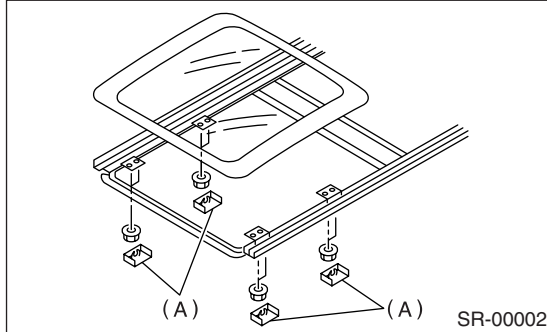

- 3) Carefully remove sunroof lid.

B: INSTALLATION

Install in the reverse order of removal.

C: ADJUSTMENT

1. ALIGNMENT OF HEIGHT BETWEEN SUNROOF LID AND ROOF PANEL

Loosen sunroof lid nuts and then adjust height by adding (max: four pieces) or extracting (min: zero piece) shims (standard: two pieces) between sunroof lid and roof panel.

Difference in height between sunroof lid and roof panel

2.0±1.0 mm (0.079±0.039 in)

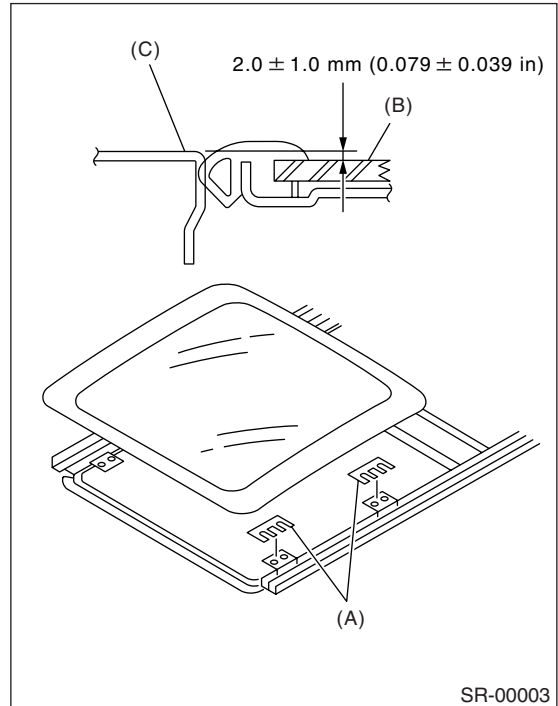

- (A) Shim
- (B) Sunroof lid
- (C) Roof panel

Sunroof Assembly

SUNROOF/T-TOP/CONVERTIBLE TOP (SUNROOF)

4. Sunroof Assembly

A: REMOVAL

- 1) Disconnect the ground cable from battery.
- 2) Remove roof trim. <Ref. to EI-47, REMOVAL, Roof Trim.>
- 3) Remove sunroof lid. <Ref. to SR-5, REMOVAL, Sunroof Lid.>
- 4) Disconnect the four drain tubes (A) from sunroof frame.
- 5) Disconnect sunroof harness connector.
- 6) Remove the bolts, and then remove the frame bracket.

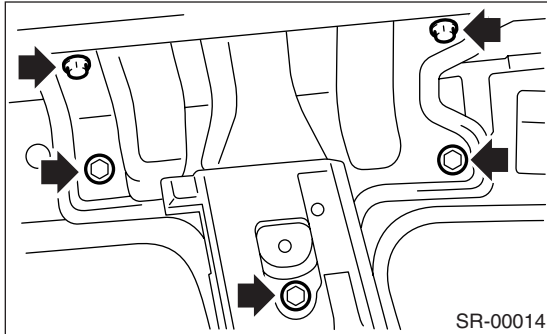

- 7) Remove bolts and nuts and then detach sunroof frame.

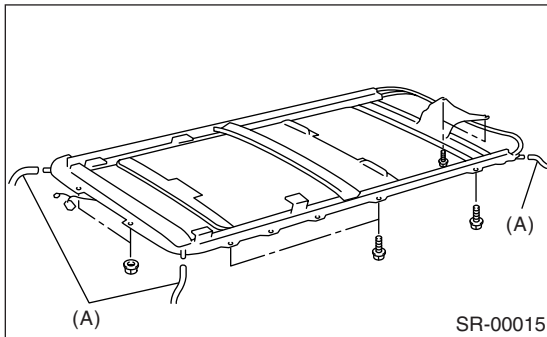

B: INSTALLATION

Install in the reverse order of removal.

CAUTION:

Be careful not to snag harness.

NOTE:

- Make sure to connect harness connector.
- When installing drain tube, insert it securely into drain pipe.

Length A:

15 mm (0.59 in) or more

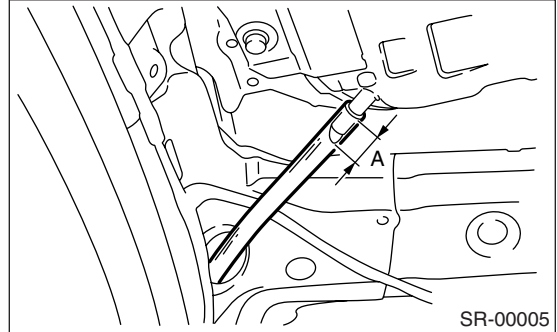

C: DISASSEMBLY

- 1) Remove sunroof frame.
- 2) Cut the pawl (A) of front sunshade RH.
- 3) Remove the front slider RH.

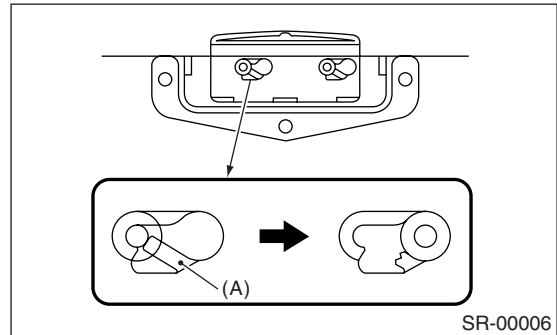

- 4) Pull out the sunshade (B) from sunroof frame.

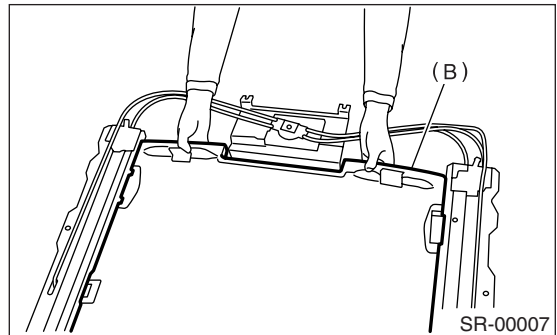

D: ASSEMBLY

Assemble in the reverse order of disassembly.

E: INSPECTION

1. CHECK FOR MOVEMENT OF SUNSHADE

1) Attach a spring scale to sunshade edge using a cloth.

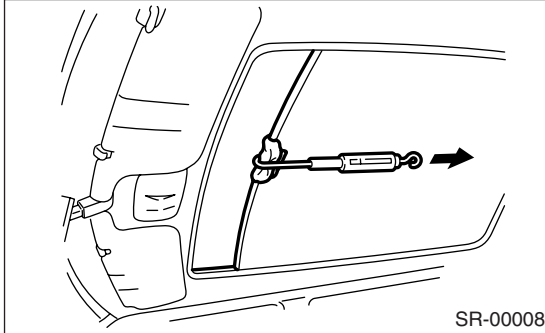

2) Pull the spring scale to measure force required to move the sunshade.

**Force required to move sunshade:
25 N (2.5 kgf, 5.5 lb) or less**

NOTE:

Considerable effort is required to start sunshade moving, so take a scale reading while sunroof panel is moving smoothly.

3) If force required exceeds specifications, check the sunroof glass lid, sunshade, deflector, and guide rail assembly for improper installation

Sunroof Motor

SUNROOF/T-TOP/CONVERTIBLE TOP (SUNROOF)

5. Sunroof Motor

A: REMOVAL

CAUTION:

- Fully close sunroof when removing sunroof motor.
- When removing clip, use great care to not damage the roof trim.

- 1) Completely close the sunroof.
- 2) Disconnect the ground cable from battery.
- 3) Remove roof trim. <Ref. to EI-47, REMOVAL, Roof Trim.>
- 4) Disconnect harness connector (A) and remove sunroof motor mounting screw (B) and nut (C).

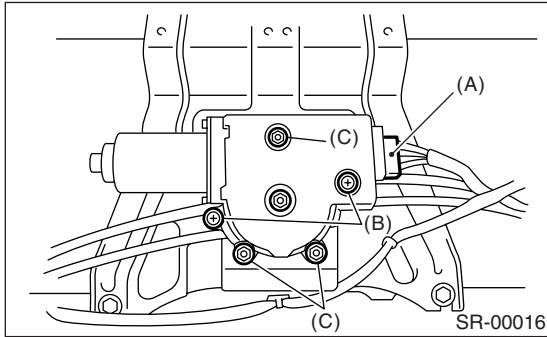

B: INSTALLATION

CAUTION:

Be careful not to move the sunroof cable when installing sunroof motor.

- 1) Install sunroof motor.
- 2) Connect sunroof motor harness connector and then connect battery ground cable.
- 3) Reset the sunroof motor. <Ref. to SR-8, ADJUSTMENT, Sunroof Motor.>
- 4) Check sunroof operation with the following procedure.

Checking order	Switch position
(1) Completely close sunroof.	Closed
(2) Open sunroof 500 mm (19.7 in) away from completely closed position.	Open
(3) Completely open sunroof.	Open
(4) Close sunroof 200 mm (7.87 in) from completely closed position.	Closed
(5) Completely close sunroof.	Closed

- 5) Install the roof trim. <Ref. to EI-47, INSTALLATION, Roof Trim.>

C: ADJUSTMENT

- 1) Reset the sunroof motor.
 - (1) Close the sunroof lid completely, and then push the switch to close for more than 1 second. (At this time, the sunroof operates 50 mm (1.97 in) each intermittently. And also the switch is needed to push for several times.)
 - (2) Open the sunroof lid approx. 400 mm (15.75 in).
 - (3) Close the sunroof lid completely, and then push the switch to close for more than 1 second. (Sunroof operates automatically by performing this operation.)

D: INSPECTION

1. AUTO REVERSE FUNCTION

- 1) Open the sunroof lid.
- 2) While the sunroof lid closing automatically, press the switch to open and check if auto reverse function operates properly.
- 3) Check that the sunroof opens 150 mm (5.91 in) by auto reverse function operated.

CAUTION:

Do not check the auto reverse operation with pinching any object.

NOTE:

- Auto function is canceled if auto reverse function operates more than five times.
- Reset if auto function is canceled. <Ref. to SR-8, ADJUSTMENT, Sunroof Motor.>

6. Sunroof Switch

A: REMOVAL

- 1) Disconnect ground cable from battery.
- 2) Remove the spot map light. <Ref. to LI-29, REMOVAL, Spot Map Light.>
- 3) Disconnect harness connectors and remove sunroof switch (A).

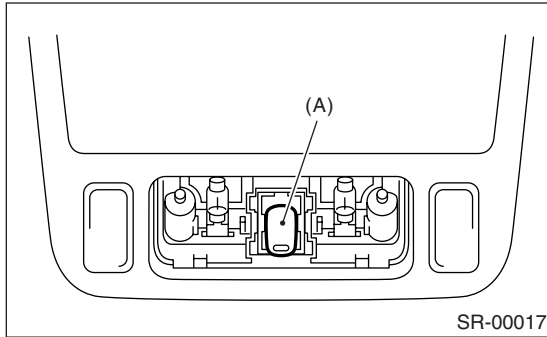

B: INSTALLATION

Install in the reverse order of removal.

C: INSPECTION

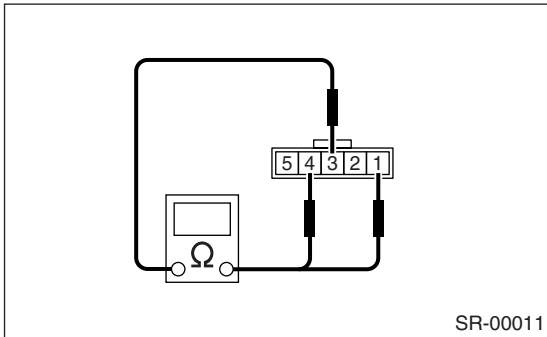

Check continuity between terminals when operating the switch.

Switch	Terminal No.	Standard value
Open	1 — 3	Less than 1 Ω
Close	3 — 4	More than 1 M Ω

Sunroof Switch

SUNROOF/T-TOP/CONVERTIBLE TOP (SUNROOF)
